

FRITEC[®]

FRICION TECHNOLOGY



Ahora!
Scanea este QR
y llévanos en tu
smartphone

**BALATAS DE FRENO DE DISCO
Y FRENO DE TAMBOR**
DISC BRAKE PADS
AND DRUM BRAKES

Catálogo 2019

Dacomsa

FRITEC®

FRICCIÓN TECHNOLOGY

BALATAS / FRENO DE DISCO Y TAMBOR



Specific

Confort y Máxima seguridad de frenado

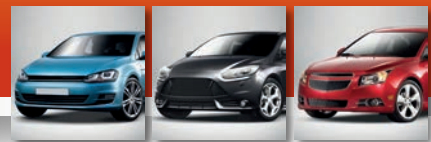

Ceramic HD

Máximo rendimiento y poder de frenado



Azul

Calidad al mejor precio



ONE WAY ▲



Specific

Confort y Máxima seguridad de frenado



Innovación continua

Capacitaciones Técnicas en línea
losespecialistas.tv

LOS **ESPECIALISTAS** 
EXPERIENCIA TÉCNICA EN ACCIÓN

Autopar[®]
BRAKES



**El complemento
perfecto**

El resultado de un frenado perfecto solo puede obtenerse con discos de freno diseñados específicamente para las pastillas de freno.

TECNOLOGÍA EN DISCOS

Filtro Térmico

Dirige la transferencia de calor de la cámara de ventilación del disco; mejora la disipación de calor evitando run-out (vibración).

Metalurgia Alta Tecnología

Proceso de fundición especial que proporciona materiales completamente homogéneos.



Superficie de Fricción

Fabricado con estándares de EO. Tolerancias y maquinados de alta precisión. Superficie con revestimiento anticorrosión.

Ventilas de enfriamiento

Optimiza la disipación de calor a través de diferentes tipos de alabes de a cuerdo a la aplicación.

Estampado

- | | |
|------------------|----------------------------|
| 1.- Proveedor | 2.- Marca (Autopar/Fritec) |
| 3.- No. de Parte | 4.- Mínimo espesor |

J	AUTOPAR/FRITEC	FR16018	MIN THK 19.4
1	2	3	4





Sección 1 / Section 1
ÍNDICE GENERAL / GENERAL LISTING



Sección 1 / Section 1
ÍNDICE GENERAL / GENERAL LISTING

Sección 1 / Section 1

Índice general / General listing 5

Sección 2 / Section 2

Fórmulas comerciales / Formulas 11

Sección 3 / Section 3

Boletines Técnicos / Technical Bulletins 17

Balata freno de disco - EPB Electronic Parking Brake - Freno Electrónico de Estacionamiento 18

EPB Electronic Parking Brake - Freno Electrónico de Estacionamiento 18

Componentes EPB 19

Tips para el reemplazo de las pastillas de freno sino cuenta con una herramienta de diagnóstico 22

Mantenimiento del Freno Electrónico de Estacionamiento EPB 23

Desensamble e inspección de los componentes internos del caliper EPB 24

Recomendaciones para una instalación adecuada de freno de disco 27

Sección 4 / Section 4

Balata freno de disco - Lista por número de parte / Part number listing 41

Sección 5 / Section 5

Balata freno de disco - Lista por FMSI / FMSI listing 49

Sección 6 / Section 6

Balata freno de disco - Lista por dimensión / Width listing 57

Sección 7 / Section 7

Balata freno de tambor - Lista por número de parte / Part number listing 65

Sección 8 / Section 8

Balata freno de tambor - Lista por FMSI / FMSI listing 69

Sección 9 / Section 9

Balata freno de tambor - Lista por diámetro / Diameter listing 73

Sección 10 / Section 10

Como utilizar lista por aplicación / freno de disco y freno de tambor 76

Lista por aplicación / Application listing 77

ACURA 77

ACURA TRUCK 77

ALFA ROMEO 77

AMC 77

AUDI 77

AUDI TRUCK 79

BMW 79

BMW TRUCK 81

BUICK 81

BUICK TRUCK 82

CADILLAC 82

CADILLAC TRUCK 83

CHEVROLET 83

CHEVROLET TRUCK 84

CHRYSLER 89

CHRYSLER TRUCK 90

DODGE 90

DODGE TRUCK 91

EAGLE 94

EAGLE TRUCK 94

FAW 94

FAW TRUCK 94

FIAT 94

FIAT TRUCK 94

FORD 94

FORD TRUCK 96

GMC 99

GMC TRUCK 99

HONDA 101

HONDA TRUCK 102

HUMMER 102

HYUNDAI 102

HYUNDAI TRUCK 103

Sección 10 / Section 10

INFINITI	103
INFINITI TRUCK	103
ISUZU TRUCK	103
JAGUAR	104
JEEP	104
KIA	105
KIA TRUCK	105
LAND ROVER	105
LEXUS	105
LEXUS TRUCK	106
LINCOLN	106
LINCOLN TRUCK	106
MAZDA	106
MAZDA TRUCK	107
MERCEDES BENZ	107
MERCEDES BENZ TRUCK	109
MERCURY	109
MERCURY TRUCK	110
MINI	110
MINI TRUCK	110
MITSUBISHI	110
MITSUBISHI TRUCK	110
NISSAN	111
NISSAN TRUCK	112
OLDSMOBILE	113
OLDSMOBILE TRUCK	114
PEUGEOT	114
PEUGEOT TRUCK	115
PLYMOUTH	115
PLYMOUTH TRUCK	115
PONTIAC	115
PONTIAC TRUCK	116
PORSCHE TRUCK	116
RAM	116
RENAULT	117
RENAULT TRUCK	117
SAAB	118
SAAB TRUCK	118
SATURN	118
SEAT	118
SEAT TRUCK	118
SUBARU	119
SUBARU TRUCK	119
SUZUKI	119
SUZUKI TRUCK	119
TOYOTA	119
TOYOTA TRUCK	120
VOLKSWAGEN	121
VOLKSWAGEN TRUCK	123
VOLVO	124
VOLVO TRUCK	124

Sección 11 / Section 11

Lista Freno de Estacionamiento / Parking Brake listing	127
--	-----

Sección 12 / Section 12

Como utilizar guía ilustrada - freno de disco	132
Balata freno de tambor - Guía ilustrada / Illustrated guide	133

Sección 13 / Section 13

Como utilizar guía ilustrada - freno de tambor	330
Balata freno de tambor - Guía ilustrada / Illustrated guide	331

FRITEC[®]
FRICTION TECHNOLOGY

FRITEC[®]
FRICTION TECHNOLOGY



Sección 2 / Section 2
FÓRMULAS COMERCIALES / COMMERCIAL FORMULAS



Sección 2 / Section 2

FÓRMULAS COMERCIALES / COMMERCIAL FORMULAS

FRITEC®

FRICCIÓN TECHNOLOGY

Specific

Confort y Máxima seguridad de frenado

Pastillas de freno Cerámicas Premium fabricadas con **Tecnología PM (Positive Molding)** y una mezcla única de **Cerámica Low-Met Patentada**, diseñada para minimizar la vibración y el ruido no deseado, ayudando al mismo tiempo a extender la vida del rotor. **Specific** proporciona potencia de frenado consistente y confortable en una amplia gama de condiciones de manejo, incluyendo paradas de pánico. Es la mejor opción para todos los autos modernos que requieren pastillas de freno con características de Equipo Original.



Backing-adhesivo fenólico
Aseguran un anclaje perfecto en toda la vida útil de la pastilla de freno.

Ranuras y chaflanes
Minimizan esfuerzos mecánicos, vibración y ruido.

Ceramic Low-Met
Fórmulas cerámicas específicas para cada auto

Sensor de desgaste
Incluye sensores acústicos y/o eléctricos de acuerdo a especificación de E.O.

Respaldo metálico
Zapatas de acero, 100% rasuradas y planchadas para un ensamble perfecto.

Laina anti-ruido
Utilizamos la más avanzada tecnología de laines anti-ruido para asegurar un frenado silencioso y confortable a nuestros usuarios.



Tecnología PM (Positive Molding)

- Otorga consistencia y fricción constante.
- Asegura el mejor desempeño de frenado.
- Proporciona mayor vida útil.
- Aumenta la resistencia al desvanecimiento por calor.

La Tecnología **PM - Positive Molding** (Moldeo Positivo) es un factor importante en la manufactura de los productos **Fritec**, utilizando el mismo proceso de fabricantes de E.O. El moldeo a presión positiva se traduce en una densidad más uniforme en las pastillas de freno aumentando la eficiencia de frenado y la vida útil del producto.



Innovación continua
Capacitaciones Técnicas en línea
losespecialistas.tv



Capacitaciones Técnicas en línea losespecialistas.tv

FRITEC®

FRICCIÓN TECHNOLOGY

Ceramic HD

Máximo rendimiento y poder de frenado

Pastillas de freno Cerámicas manufacturadas con **Tecnología PM (Positive Molding)** y una mezcla única de **Cerámica Alto Carbón Patentada**, que ofrece máxima fricción y compatibilidad con el rotor, asegurando el funcionamiento y máximo rendimiento en los diferentes vehículos para los que ha sido diseñada, eliminando prácticamente rechinidos y vibraciones. **Ceramic HD** es ideal para unidades que necesitan una fuerza de frenado adicional para los altos retos de trabajo a los que son sometidas. Autos, camionetas y camiones de uso extremo, como vehículos de flotillas, emergencia (patrullas y ambulancias) y blindados.



Backing-adhesivo fenólico
Aseguran un anclaje perfecto en toda la vida útil de la pastilla de freno.

Ceramic High-carbon
Fórmulas cerámicas alto carbón específicas para uso rudo.

Malla electrosoldada
Aseguran un anclaje perfecto en toda la vida de la pastilla de freno.

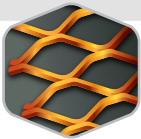

Respaldo metálico
Zapatillas de acero, 100% rasuradas y planchadas para un ensamble perfecto.

Sensor de desgaste
Incluye sensores acústicos y/o eléctricos de acuerdo a especificación de E.O.

Ranuras y chaffanes
Minimizan esfuerzos mecánicos, vibración y ruido.

Laina anti-ruido
Utilizamos la más avanzada tecnología de laines anti-ruido para asegurar un frenado silencioso y confortable a nuestros usuarios.

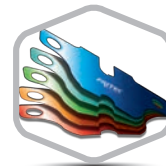

Tecnología PM (Positive Molding)

- Otorga consistencia y fricción constante.
- Asegura el mejor desempeño de frenado.
- Proporciona mayor vida útil.
- Aumenta la resistencia al desvanecimiento por calor.

La Tecnología **PM - Positive Molding** (Moldeo Positivo) es un factor importante en la manufactura de los productos **Fritec**, utilizando el mismo proceso de fabricantes de E.O. El moldeo a presión positiva se traduce en una densidad más uniforme en las pastillas de freno aumentando la eficiencia de frenado y la vida útil del producto.



Capacitaciones Técnicas en línea loespecialistas.tv



Innovación continua

Capacitaciones Técnicas en línea
loespecialistas.tv

FRITEC®

FRICCIÓN TECHNOLOGY

Azul

Calidad al mejor precio

Pastillas de freno Cerámicas manufacturadas con **Tecnología PM (Positive Molding)** y formulaciones **Orgánicas** y/o **Semi-metálicas** con fibras cerámicas y grafito diseñadas para ser más silenciosas y más durables. Las pastillas de freno **FRITEC Azul** proporcionan un alto rendimiento y frenado seguro para todos los autos del parque vehicular nacional e importados.



Nuevas formulaciones
Fórmulas orgánicas, cerámicas y semimetálicas, específicas para cada auto.

Ranuras y chafanes
Minimizan esfuerzos mecánicos, vibración y ruido.

Sensor de desgaste
Incluye sensores acústicos y/o eléctricos de acuerdo a especificación de E.O.

Backing-adhesivo fenólico
Aseguran un anclaje perfecto en toda la vida útil de la pastilla de freno.

Laina anti-ruido
Utilizamos la más avanzada tecnología de laines anti-ruido para asegurar un frenado silencioso y confortable a nuestros usuarios.

Respaldo metálico
Zapatillas de acero, 100% rasuradas y planchadas para un ensamble perfecto.



Tecnología PM (Positive Molding)

- Otorga consistencia y fricción constante.
- Asegura el mejor desempeño de frenado.
- Proporciona mayor vida útil.
- Aumenta la resistencia al desvanecimiento por calor.

La Tecnología **PM - Positive Molding** (Moldeo Positivo) es un factor importante en la manufactura de los productos **Fritec**, utilizando el mismo proceso de fabricantes de **E.O.** El moldeo a presión positiva se traduce en una densidad más uniforme en las pastillas de freno aumentando la eficiencia de frenado y la vida útil del producto.



Innovación continua
Capacitaciones Técnicas en línea
losespecialistas.tv



Capacitaciones Técnicas en línea losespecialistas.tv

FRITEC®

FRICCIÓN TECHNOLOGY

Specific

Confort y Máxima seguridad de frenado

ONE WAY ▲

Es la línea que ofrece materiales libres de asbesto con calidad EO. Ideal para usuarios que exigen un frenado silencioso, cómodo y seguro.



Característica

- Fórmulas libres de asbesto.
- Zapatas nuevas con pernos, levas y chavetas incluidos de acuerdo a Equipo Original (EO).
- Disponible en Vulcanizado y/o Remachado.
- La mayor cobertura del parque vehicular nacional.
- También disponible en sobremedida: One Way con X.



Beneficio

- Balance de frenado óptimo entre el eje delantero y trasero.
- Garantizan el perfecto ensamble y óptimo funcionamiento.
- De acuerdo a especificaciones de Equipo Original (EO).
- Vehículos nacionales e importados: Americanos, Asiáticos y Europeos.
- Especial para tambores rectificadas por primera vez.

LOS ESPECIALISTAS
EXPERIENCIA TÉCNICA EN ACCIÓN

Capacitaciones Técnicas en línea losespecialistas.tv



Innovación continua

Capacitaciones Técnicas en línea
losespecialistas.tv



Sección 3 / Section 3
BOLETINES TÉCNICOS / TECHNICAL BULLETINS



Sección 3 / Section 3
BOLETINES TÉCNICOS / TECHNICAL BULLETINS



FRENO ELECTRÓNICO DE ESTACIONAMIENTO
ELECTRONIC PARKING BRAKE
EPB

**FUNCIONAMIENTO, PROCEDIMIENTO PARA EL REMPLAZO
DE LAS PASTILLAS DE FRENO Y MANTENIMIENTO DEL CALIPER EPB**



FRENO ELECTRÓNICO DE ESTACIONAMIENTO
ELECTRONIC PARKING BRAKE
EPB

**FUNCIONAMIENTO, PROCEDIMIENTO PARA EL REMPLAZO
DE LAS PASTILLAS DE FRENO Y MANTENIMIENTO DEL CALIPER EPB**

EPB ELECTRONIC PARKING BRAKE

Freno Electrónico de Estacionamiento

Los avances en el área automotriz son cada día mayores, los sistemas se mejoran para un mayor rendimiento, confort y automatización. El freno de mano y/o pedal de freno que por muchas décadas ha sido completamente mecánico, no se escapa a estos avances tecnológicos, la gestión electrónica ha desplazado las palancas y pedales convencionales por un sencillo interruptor.



Interruptor EPB



Interruptor EPB

COMPONENTES EPB

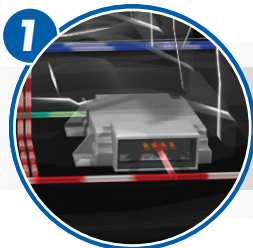

1 **Unidad de control**
encargada de gestionar la activación de los actuadores, para aplicar o liberar el freno de estacionamiento.



2 **Interruptor de parking**
bloquea y desbloquea a voluntad el freno, ubicado en el tablero principal o consola central.



3 **Interruptor AutoHold:**
activa las asistencias de seguridad.



4 **Captador de posición de pedal de embrague:**
informa el punto de salida del pedal del embrague, (no aplica en caja automática).



5 **Testigo visual y acústico:**
informa su activación y/o fallo, del sistema.

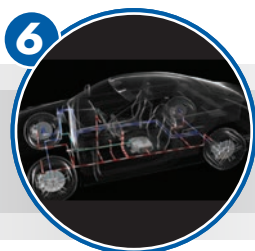

6 **Red multiplexada del vehículo:**
transmite los datos necesarios para el funcionamiento.

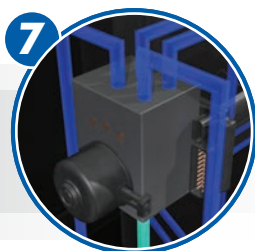

7 **Frenos ABS:**
sistema principal para el funcionamiento del EPB.

VENTAJAS DEL FRENO DE ESTACIONAMIENTO (EPB)

AutoHold - Sistema de seguridad que gestiona las siguientes asistencias:

1

Hill start assist-

Inmoviliza el vehículo en una pendiente para evitar el retroceso involuntario del vehículo y se desactiva en el momento en que el conductor pisa el acelerador.

2

Activación automática al apagar el motor avisando por medio de una luz testigo en el tablero de instrumentos.

3

Al abrir una puerta o al desabrocharse el cinturón con el motor en marcha, este se activa como medida de seguridad.

4

En caso de requerirse, funcionara con el vehículo en marcha como freno de emergencia, haciendo una regulación de la frenada con la asistencia del ABS evitando el bloqueo de las ruedas.

4

El ABS podrá gestionar los calipers de EPB mejorando así la eficacia y seguridad durante una frenada de pánico/o emergencia.



Hill Start Assist



Activación automática



Gestión de calipers de EPB

Nota: Para llevar a cabo el reemplazo de las pastillas de freno con sistema EPB, es necesario la utilización de una herramienta de diagnóstico y seguir las recomendaciones a continuación descritas.



Scanner EPB



Herramientas de diagnóstico automatiz

RECAMBIO DE LAS PASTILLAS DE FRENO UTILIZANDO UNA HERRAMIENTA DE DIAGNÓSTICO



Asegúrese de liberar el freno de estacionamiento y mantener desactivado el **AutoHold**.



Con el switch en **posición OFF**, conecte la herramienta de diagnóstico al OBDII del vehículo y gire el switch en posición **ON**.

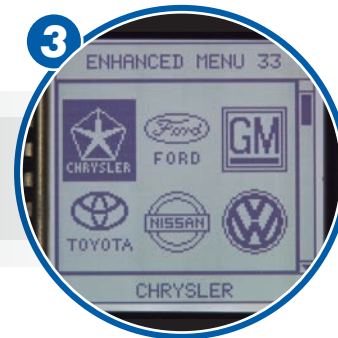

Con el switch en **posición OFF**, conecte la herramienta de diagnóstico al OBDII del vehículo y gire el switch en posición **ON**.



Localice en el menú la opción **Parking Brake** o las siglas **EPB**, dependiendo del Scanner.



Seleccione la opción de **retracción** o **retroceso de calipers**.



Una vez retraídos los pistones de caliper en su funcionamiento electromecánico, aparecerá el **testigo de Parking** en el panel de instrumentos, coloque el switch en **posición OFF**.

RECAMBIO DE LAS PASTILLAS DE FRENO UTILIZANDO UNA HERRAMIENTA DE DIAGNÓSTICO



Desconecte la herramienta de diagnóstico y proceda con el desmontaje de los calipers.



Lave y lubrique todos los componentes de caliper, verifique el buen estado de los herrajes y pernos, asegúrese que los discos se encuentren dentro de especificación.



Realice el retorno del pistón de freno del disco, utilizando un oprobresor para pistones huecos. Consulte el boletín técnico "Recomendaciones para una adecuada instalación de pastillas de freno de disco", instale un juego de pastillas de freno nuevas y ensamble la pinza de caliper.

Advertencia: Nunca utilice el oprobresor para pistones sólidos traseros.
Precaución: Una vez concluido el mantenimiento, no olvide bombear el pedal de freno para cargar nuevamente los calipers de líquido, el pedal de freno debe estar alto y duro.



Conecte nuevamente la herramienta de diagnóstico, coloque el switch en posición ON e ingrese a cierre de caliper/ajuste o calibración de caliper.



Para asegurar que todo se encuentra bien, por último ingresaremos a la opción leer códigos de falla.



Finalmente coloque el switch en posición OFF y desconecte la herramienta de diagnóstico.

Nota: Las imágenes son referenciales y podrían variar dependiendo del equipo de diagnóstico a utilizar.

TIPS PARA EL REEMPLAZO DE LAS PASTILLAS DE FRENO SINO CUENTA CON UNA HERRAMIENTA DE DIAGNÓSTICO

Para retroceder el pistón de freno, realice los siguientes pasos:



Asegúrese de liberar el freno de estacionamiento.



Realice el **desmontaje de la pinza de freno** y retire las pastillas de freno usadas.



Retire los 2 tornillos tipo Torx T-30, para desacoplar el actuador del EPB de la mordaza.

Nota: Cuidé de no dañar el sello tipo O ring, de lo contrario se presentaran problemas de contaminación y desgaste prematuro en los componentes internos (rodamientos y motor eléctrico).

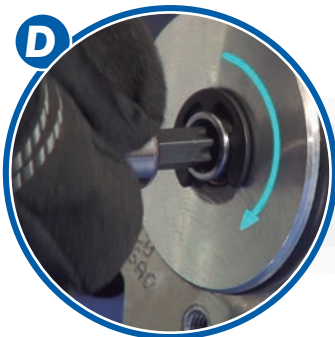

Gire en sentido de las manecillas del reloj el eje de articulación para retroceder hasta su punto muerto inferior la tuerca mariposa, utilice una punta Torx T-40.

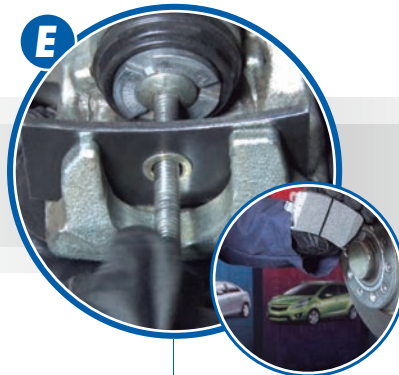

Realice el retroceso del pistón de freno, consulte el boletín técnico **"Recomendaciones para una adecuada instalación de pastillas de freno de disco"**, utilice un opresor para pistones huecos, instale un juego de pastillas de freno nuevas y ensamble la pinza de caliper.

Advertencia: Nunca utilice el opresor para pistones sólidos traseros.



Active y desactive 3 veces el interruptor del EPB, para activar la función de Auto calibración (holgura de trabajo entre la pastillas de freno y el disco).

Precaución: Una vez concluido el mantenimiento, no olvide bombear el pedal de freno para cargar nuevamente los calipers de líquido, el pedal de freno debe estar alto y duro.

MANTENIMIENTO DEL FRENO ELECTRÓNICO DE ESTACIONAMIENTO EPB

Componentes internos del actuador del EPB

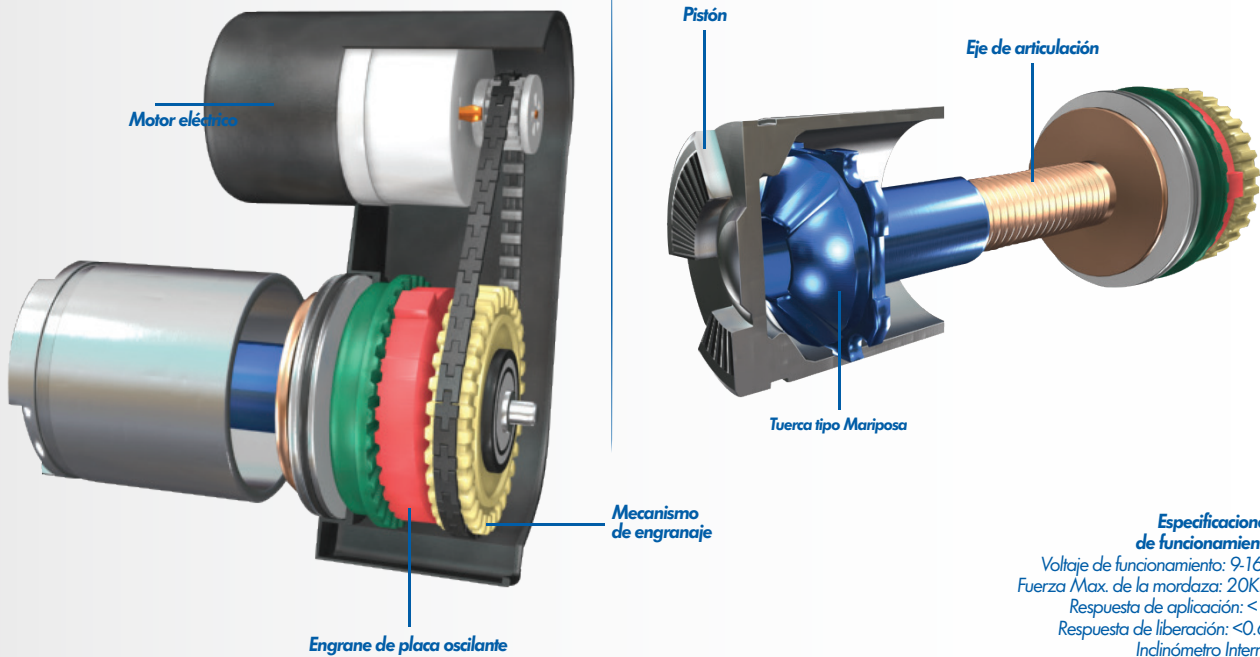

Especificaciones de funcionamiento
 Voltaje de funcionamiento: 9-16V
 Fuerza Max. de la mordaza: 20KN
 Respuesta de aplicación: <1s
 Respuesta de liberación: <0.6s
 Inclinómetro Interno

EN CASO DE REQUERIR EL REPLAZO DEL REPUESTO DE CALIPER, LE RECOMENDAMOS SEGUIR LOS SIGUIENTES PASOS

Desensamble de los componentes:



A Desconecte el amés del actuador del EPB.

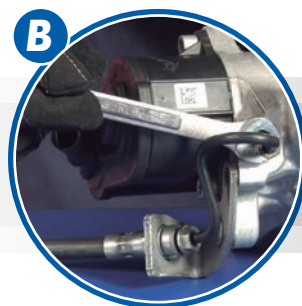

B Retire la conexión hidráulica (coloque ahorradores en las mangueras) y la mordaza del caliper.

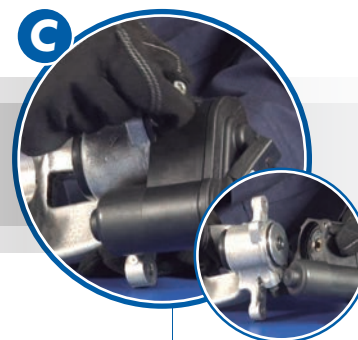

C Una vez desmontado el conjunto electromecánico, retire los 2 tornillos tipo Torx T-30, que sujetan el actuador del EPB a la pinza de caliper.

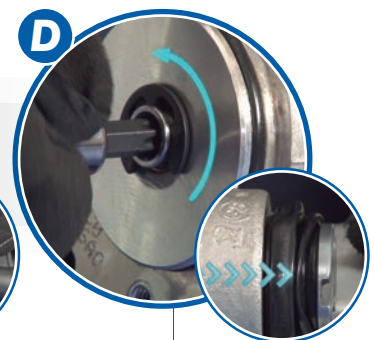

D Utilice una punta Torx T-40 para extraer el pistón y la tuerca mariposa del caliper, gire en sentido contrario a las manecillas del reloj el eje de articulación.

DESENSAMBLE E INSPECCIÓN DE LOS COMPONENTES INTERNOS DEL CALIPER EPB

Para retroceder el pistón de freno, realice los siguientes pasos:



E Inspeccione visualmente la tuerca mariposa para descartar algún daño, revise cuerda y zona de contacto.

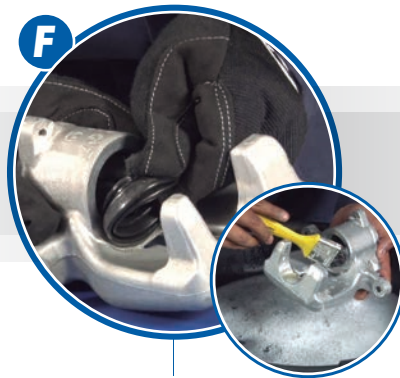

F Retire el cubre polvo y la liga, lave la mordaza y el alojamiento del pistón, utilice preferentemente un desengrasante biodegradable, utilice una lija fina de agua en caso de existir corrosión.



G Precaución: Evite mojar la zona de acoplamiento con el módulo de accionamiento, de lo contrario los rodamientos internos sufrirán daños.

ENSAMBLE DE LOS COMPONENTES INTERNOS DEL CALIPER EPB



A Instale la liga de caliper, prelubricada con grasa base silicón.



B Lubrique la cuerda de la tuerca mariposa e introdúzcala en el eje de articulación, girándola en sentido horario en su totalidad.



C Instale el cubrepolvo, cuidando la posición y verificando el correcto acoplamiento en el alojamiento del caliper.

ENSAMBLE DE LOS COMPONENTES INTERNOS DEL CALIPER EPB

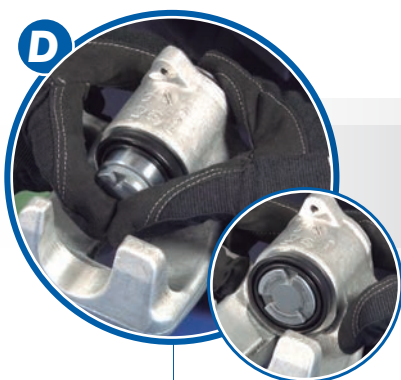

D Introduzca el pistón considerando sus guías con las de la tuerca mariposa.



E Ensamble el módulo de accionamiento en la mordaza de caliper, aplicando un torque de 12 Nm (9 lb/ft) en los 2 tornillos de sujeción T-30.



F Conecte la línea hidráulica, ensamble la mordaza en el porta caliper y conecte el armés del módulo de accionamiento del EPB.



G Realice un procedimiento de purga, consulte el boletín técnico "Purgado del sistema", para llevar a cabo este procedimiento.



H Conecte la herramienta de diagnóstico, coloque el switch en posición ON e ingrese a cierre de caliper/ajuste o calibración de caliper.



C Verifique que no existan códigos de falla, ingrese a la opción leer códigos de falla.



D Finalmente coloque el switch en posición OFF y desconecte la herramienta de diagnóstico.

Nota: Si no cuenta con una herramienta de diagnóstico, active y desactive 3 veces el interruptor del EPB, para activar la función de Auto calibración del EPB (holgura de trabajo entre las pastillas de freno y el disco).

PARA FINALIZAR, LE RECOMENDAMOS LLEVAR A CABO UN RECORRIDO DE PRUEBA, PARA ASEGURAR QUE EL MANTENIMIENTO REALIZADO FUE EL ADECUADO Y EL SISTEMA TRABAJA CORRECTAMENTE

Para mas información consulte el video:

"FUNCIONAMIENTO Y MANTENIMIENTO DEL FRENO ELECTRÓNICO DE ESTACIONAMIENTO EPB"



Dirección electrónica
www.tusfrenos.com

RECOMENDACIONES

Diagnóstico

Antes de proceder con el desarmado y/o reemplazo de algún componente, es importante verificar la condición general en que se encuentra el vehículo, le recomendamos manejar el vehículo y/o indagar más a fondo sobre la problemática reportada por el usuario.



Maneje el vehículo para verificar condición



Indague más a fondo sobre la problemática reportada por el usuario

Seguridad

Asegúrese que las condiciones de trabajo y el equipo a utilizar cumplan con las especificaciones necesarias para llevar a cabo el mantenimiento requerido:

- 1** Estacione el vehículo en una superficie plana y de concreto.
- 2** Aplique siempre el freno de estacionamiento.
- 3** Verifique que los elementos de elevación se encuentren en buen estado y que cumplan con los rangos de tonelaje al que serán sometidos.
- 4** En caso de no utilizar rampas de elevación, siempre debe utilizar torres de apoyo, colocándolas en las costillas del chasis del vehículo para un apoyo seguro.
- 5** Dependiendo del eje a trabajar, considere el bloqueo de las ruedas del eje opuesto, para evitar deslizamientos involuntarios del vehículo, mediante el uso de elementos de bloqueo.



INSPECCIÓN GENERAL

Considere los siguientes puntos:

- 1 Afloje tuercas o birlos de sujeción de las ruedas, siguiendo una secuencia en forma de cruz.
- 2 Asegúrese de contar con las herramientas adecuadas para realizar el mantenimiento y/o reparación, tomando en cuenta el sistema de frenos del vehículo a trabajar.
- 3 Siempre realice una inspección general a los componentes periféricos del vehículo como son las ruedas y suspensión de ambos ejes (en caso de identificar componentes dañados o en mal estado estos deberán ser reemplazados por nuevos).

COMPONENTES PERIFERICOS

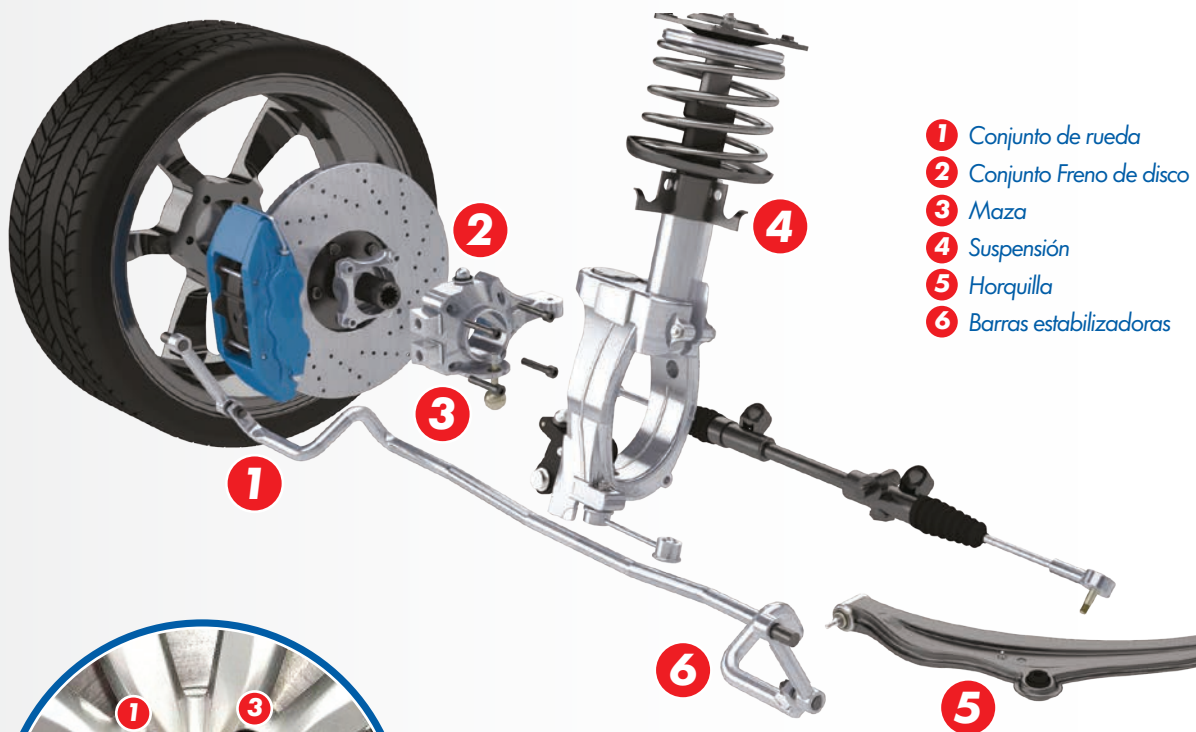

SECUENCIA DE APRIETE

Una vez realizada la inspección de los componentes periféricos, proceda con el desmontaje y la inspección de cada uno de los componentes del sistema de frenos, tomando en cuenta la secuencia que aparece arriba.

REVISIÓN E INSTALACIÓN. COMPONENTES DEL SISTEMA DE FRENOS

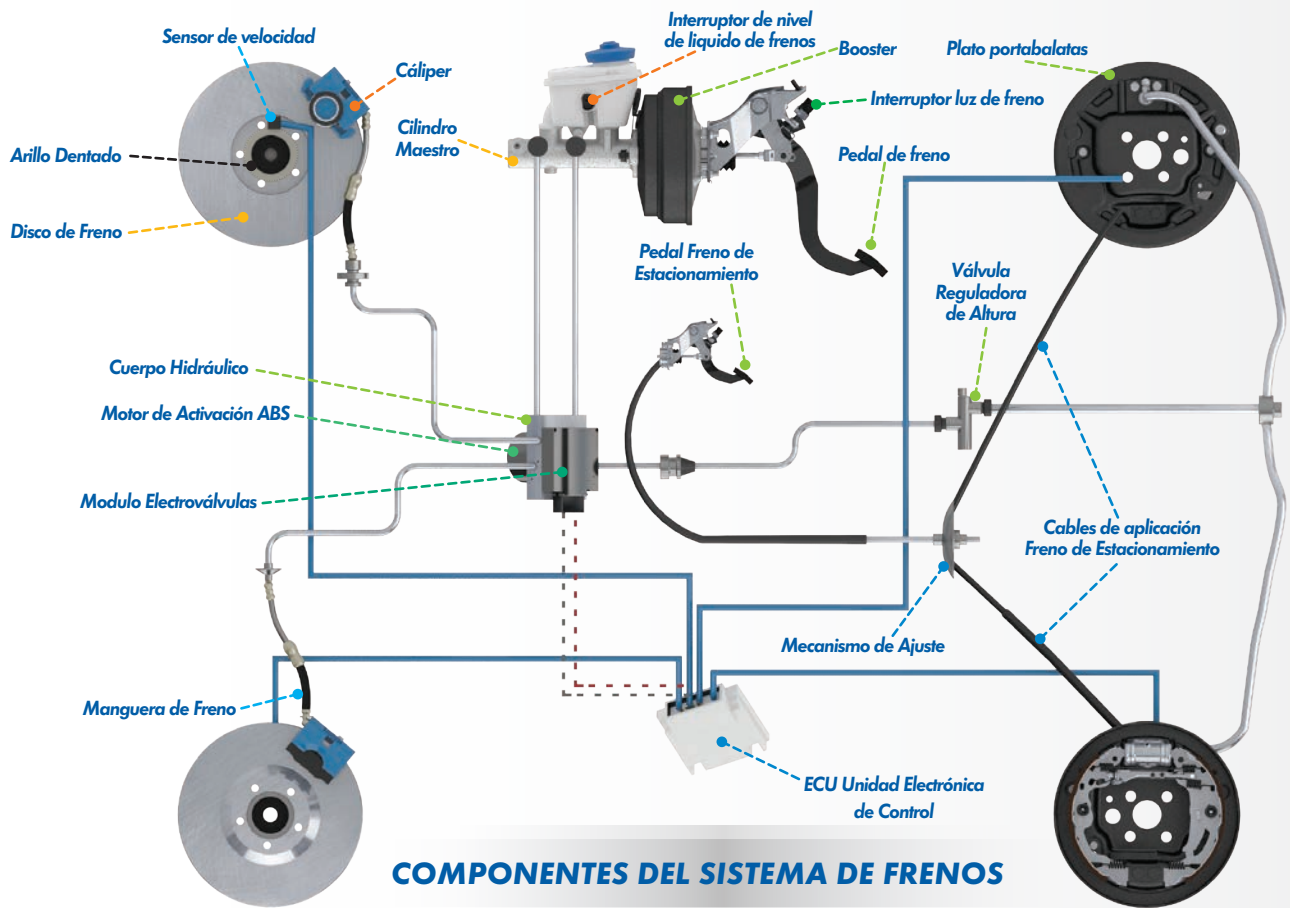

REVISIÓN E INSTALACIÓN. COMPONENTES DEL SISTEMA DE FRENOS

Inspección al desarmado y limpieza de los componentes de freno.

Esta acción ayudara a identificar qué tipo de mantenimiento es el que requiere el vehículo a trabajar.

Es necesario que estos se encuentre limpios para una fácil detección de daños.

Para este fin le recomendamos utilizar agua y jabón o preferentemente un desengrasante que sea biodegradable.

Nota: Reemplace todos los componentes dañados por nuevos.



1) TUBERÍAS Y MANGUERAS

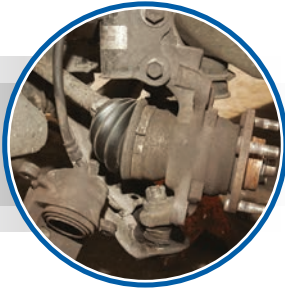

Componentes en óptimas condiciones



Estado del componente.

- Resqueidad.
- Grietas.
- Abombamientos.
- Dobleces.
- Fisuras - fugas.

Origen del daño.

- Mangueras endurecidas por antigüedad.
- Utilización de ahorcadores en mangueras dañadas.
- Colocación inadecuada del caliper.
- Dejar los calipers colgados de las mangueras.

Recomendación / Acciones a seguir.

- Reemplace los componentes dañados.
- Reemplace el líquido de frenos.

TABLA DE RECOMENDACIONES PARA CAMBIO DE LÍQUIDO DE FRENOS

Tipo de servicio	Periodo de recambio
Particular sin ABS	Cada 2 años
Intensivo sin ABS	Cada año
Particular con ABS	Cada año
Intensivo con ABS	Cada 8 meses

- Siempre coloque ganchos de sujeción para evitar que los calipers cuelguen de las mangueras.

2) PERNO GUÍA

Verifique que este se encuentre libre de golpes o deformaciones, de lo contrario reemplácela.

Pernos guía

Componentes dañados

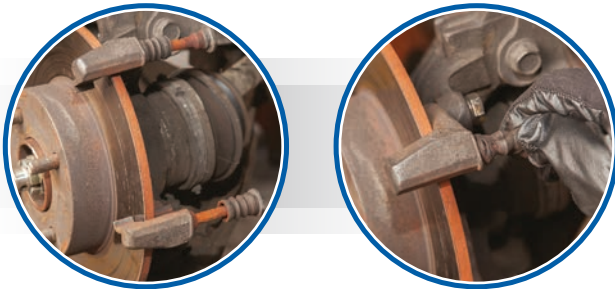

Componentes en óptimas condiciones

Fig.1

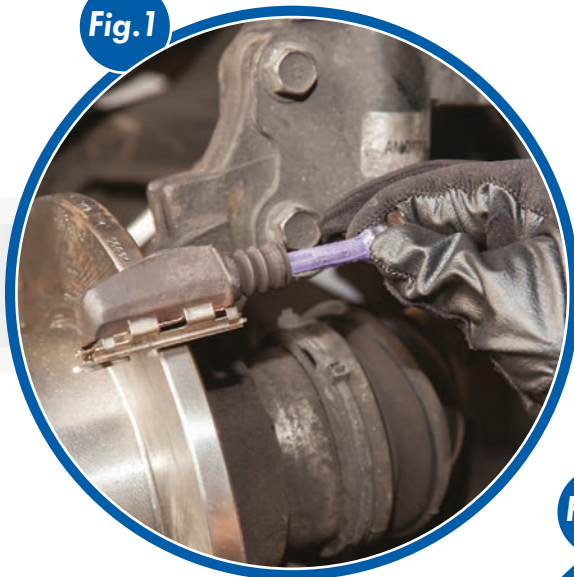

Estado del componente.

- Oxidados.
- Resecos.
- Deformados.
- Con desgaste excesivo.
- Cabeza y cuerda barrida.
- Cubrepolvos hinchados y/o rotos.

Origen del daño.

- Aprietes excesivos.
- Falta de lubricación o utilización de grasa inadecuada.
- Exceso de temperatura.

Recomendación / Acciones a seguir.

- Utilice un desengrasante biodegradable para remover impurezas.
- Lubrique con grasa base silicón recomendada para contacto hule-metal, para favorecer el libre deslizamiento y evitar dañar los hules. **Fig.1.**
- Verifique la correcta instalación de los tornillos y de los cubrepolvos en los pernos guía.
- Asegure dar el torque recomendado por el fabricante.
- Si estos presentan daños reemplácelos por unos nuevos. **Fig. 2.**

Nota: Nunca lubrique utilizando grasa para balero o grafitada, ya que por ser un derivado del petróleo, degradará e inchará los hules.

Fig.2



MORDAZA DEL CALIPER PISTÓN, CUBREPOLVOS Y LIGAS DE CALIPER

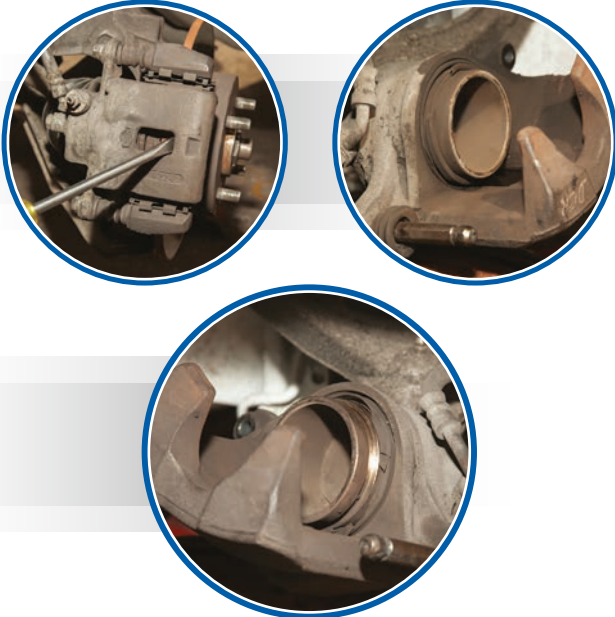

Componentes en óptimas condiciones

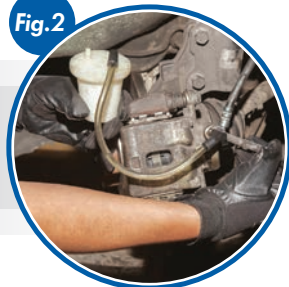

Estado del componente.

- Endurecimiento.
- Deformación.
- Rupturas y/o fugas de líquido de frenos.
- Pistones pegados.

Origen del daño.

- Material degradado por la acción de la temperatura y falta de recambio (mantenimiento preventivo).
- Exceso de temperatura de trabajo en el sistema.
- Retorno del pistón de caliper utilizando una herramienta inadecuada al recambio de las balatas.

Recomendación / Acciones a seguir.

Retorno del pistón.

Siempre abra el tornillo purgador para retornar el pistón y así evitar contrapresiones, daños en las ligas del caliper y cuerpo hidráulico en el caso de los vehículos equipados con ABS. ** Utilice un depósito recolector de líquido de frenos, ya que éste es altamente corrosivo y contaminante. **Fig.1.**

Pistón hueco.

Utilice un opresor de balatas y/o pinza tipo carpintero. **Fig. 2.**

Pistón sólido.

Utilice el kit de opresores para pistones sólidos traseros, considere la dirección del giro (marca y modelo de vehículo). **Fig. 3.**

- Si es necesario el recambio de alguno de éstos componentes al armado, utilice grasa base silicón recomendada para contacto hule-metal, para una fácil instalación y evitar dañar la liga de caliper. ** La instalación de estos componentes deberá ser de forma manual.

- En vehículos de uso particular, le recomendamos hacer el reemplazo de éstos componentes cada 3 juegos de balatas, y para uso intensivo cada cambio de balatas.

Nota: Ver tabla **FRITEC** de daños comunes a balatas y discos.

3) PORTA CALIPER

Siempre verifique el buen estado de la cuerda y cabeza de los tornillos, así como del estado de las cuerdas del porta caliper, de lo contrario reemplácelos.

Balatas (Pastillas)

Componentes dañados

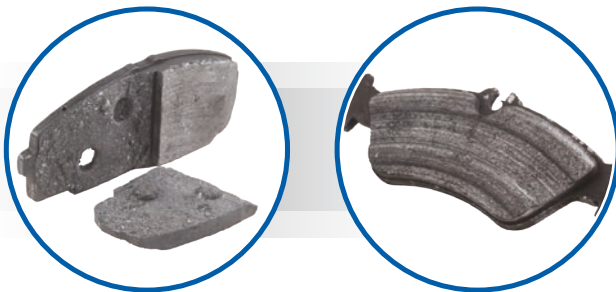

Componentes en óptimas condiciones



Estado del componente.

- Cristalizadas.
- Agrietadas.
- Escalonadas.
- Acuñadas.
- Desgaste desigual.
- Zapata doblada con desprendimiento de la pastilla.

Interpretación.

- Exceso de temperatura de trabajo y/o abuso del pedal de freno.
- Pernos guías y/o pistones pegados.
- Liga endurecida y cubrepolvos de caliper dañados.
- Discos fuera de especificación, torcidos y/o con excesiva ceja.
- No se instalaron los alambres separadores.
- Aplicación incorrecta de la balata (números similares).
- Contaminación de la pastilla con grasa o algún agente externo.
- Aplicación de silicón en las zapatas y/o en los respaldos de los herrajes en la instalación.

Recomendación / Acciones a seguir.

- Asegúrese de seleccionar la aplicación correcta para el vehículo.
- Una vez seleccionado el tipo de balatas a instalar, lubrique la zona de contacto de la zapata con las guías, utilizando grasa base molibdeno, recomendada para contacto metal-metal, favoreciendo el deslizamiento.
- Si la aplicación lo requiere instale el juego de alambres separadores. (Consulte guía para la correcta colocación de los alambres separadores), y/o instale los muelles exteriores de caliper.
- Verifique que la balata desplace libremente en las guías del caliper.

Nota: Evite contaminar los discos y balatas con grasas y/o lubricantes durante el armado. Consulte la guía FRITEC de daños comunes a balatas.

HERRAJES



Componentes en óptimas condiciones

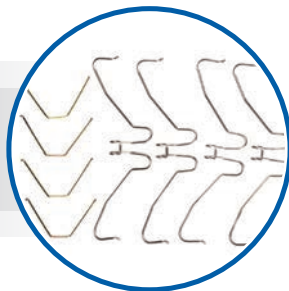

Estado del componente.

- Falta del componente.
- Rotos.
- Desgastados.
- Deformados.
- Sin brío.

Origen del daño.

- Falta de recambio (mantenimiento preventivo).
- Mala instalación.
- Aplicación incorrecta.
- Herraje modificado.

Recomendación / Acciones a seguir.

Preferentemente instale un juego de herrajes nuevo y asegure que la instalación sea la correcta y que éstos queden fijos en el porta-caliper.

Lave y elimine óxido e impurezas del porta-caliper y asegure el correcto ensamble.

4) DISCOS

Estado del componente.

- Cejas.
- Fisuras.
- Rayados.
- Fracturados.
- Excesivamente delgados.
- Contacto desigual (alabeo).
- Coloración azulada y/o desgaste desigual de las pistas.



Fig.1



Fig.2



Fig.3

Origen del daño.

- Discos excesivamente desgastados por debajo del mínimo espesor.
- Exceso de temperatura de trabajo.
- Líquido de frenos degradado.
- Balatas de baja calidad.
- Falta de ajuste en eje trasero (freno de tambor) y/o balatas de baja calidad.
- Malos hábitos de manejo y sobrecarga.
- Aplicación inadecuada y/o modificaciones realizadas al vehículo.
- Pernos guía y pistones pegados por falta de recambio y/o lubricación.

Recomendación / Acciones a seguir.

- Con un Vernier para disco. **Fig.2.** Compara este valor con el especificado por el fabricante MIN THK que se localiza marcado en el material "copa o canto del disco" dependiendo del fabricante. **Fig.1.** Si la lectura obtenida es menor a la indicada, éstos deberán ser reemplazados.
- Si el disco se encuentra dentro de especificación, verifique el alabeo/ovalamiento utilizando un indicador de carátula con una base imantada, si la lectura obtenida supera las 0.005", éste deberá ser reemplazado.
- En caso de retirar los discos para ser rectificadas márkuelos con una referencia de instalación y de posición de los mismos.
- Al instalar discos nuevos, éstos deberán ser limpiados con un solvente, agua y jabón.
- Si los discos fueron rectificadas, utilice una lija grado 200 para dar un acabado fino y así eliminar los filos del corte, posteriormente lávelos con agua y jabón e instáuelos considerando la posición marcada al desmontaje.
- Retire el óxido e impurezas del barreno central de la maza y de la copa interna del disco, para garantizar un correcto asentamiento entre éstos componentes, utilice un cepillo de alambre.
- Asegure que la posición del disco sea la correcta (disco direccional), así como la aplicación a instalar.
- Coloque tornillo fijador (en caso de requerirse).

Nota: Evite contaminar los discos y balatas con grasas y/o lubricantes durante el armado. Consulte la guía FRITEC de daños comunes a balatas.

5) MAZAS DE RUEDA



Remueva óxido e impurezas de la superficie de contacto de la maza utilizando un cepillo de alambre.

Limpie la superficie de contacto utilizando un solvente.

Verifique que la superficie se encuentre libre de golpes o deformaciones y verifique, que tanto el juego axial como el radial se encuentren dentro de especificación, de lo contrario reemplace la maza de rueda.

Utilice un indicador de carátula con un bloque imantado para verificar las holguras que se tienen en la brida de la maza:



Holgura en rodamientos

El juego radial (oscilación lateral), así como el juego axial de la maza de rueda no debe exceder 0.002", de lo contrario deberá reemplazarla.

6) FRENO DE TAMBOR

Componentes dañados

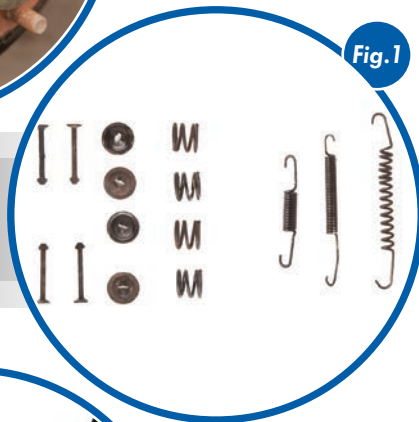

Componentes en óptimas condiciones

Estado del componente.

- Tambores (rayados, azulados, ovalados, diámetro fuera de especificación).
- Cilindro de rueda con fuga de líquido de frenos.
- Purgadores dañados.
- Herrajes y ajustadores en mal estado.
- Plato porta balatas desgastado y/o torcido.

Origen del daño.

- Sobre ajuste y continuos ajustes de las balatas.
- Aplicación incorrecta (números similares).
- Incorrecta aplicación de balatas en sobremedida.
- Falta de recambio de elementos dañados (mantenimiento preventivo).

Recomendación / Acciones a seguir.

- Utilice un escantillón para asegurar el ajuste correcto de las ruedas. **Fig.2.**
- Si algún componente de la herrajería se encuentra dañado, reemplácelo. **Fig.1.**
- Si al medir los tambores se encuentran con un diámetro mayor al especificado por el fabricante, deberá reemplazarlos. **Fig.3.**

Nota: Asegúrese de dar el torque especificado por el fabricante a los birlos de sujeción, para rin de aluminio es de 90 a 100 lbs - ft, y para rin de placa-acero es de 100-115 lbs - ft.



7) CILINDRO MAESTRO

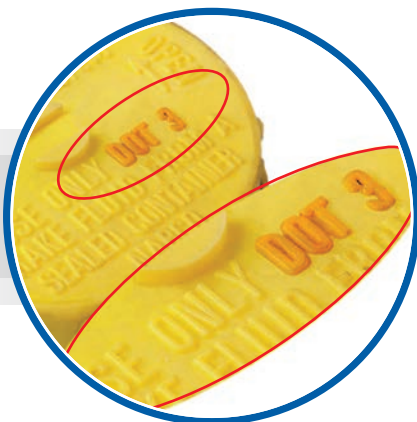

Verifique el estado de líquido de frenos preferentemente utilizando una herramienta de diagnóstico, en caso de presentarse fugas de líquido de frenos en el repuesto del cilindro o en las conexiones, asegure primeramente el correcto apriete de las mismas, de continuar presentando la falla, el componente deberá ser reemplazado por uno nuevo.

Estado del componente.

- Fugas.
- Líquido de frenos sucio, degradado y/o contaminado.
- Depósito sin tapa.

Origen del daño.

- Gomas del cilindro dañadas.
- Falta de recambio periódico del líquido de frenos.
- Cuerdas de las conexiones dañadas.

Recomendación / Acciones a seguir.

- Verifique el nivel del líquido de frenos.
- Utilice el tipo de líquido de frenos recomendado por el fabricante indicado en la tapa o depósito "DOT 3 o DOT 4".
- Recambie el líquido de frenos periódicamente, considerando el uso y si el vehículo está equipado con ABS.

TABLA DE RECOMENDACIONES PARA CAMBIO DE LÍQUIDO DE FRENOS

Tipo de servicio	Periodo de recambio
Particular sin ABS	Cada 2 años
Intensivo sin ABS	Cada año
Particular con ABS	Cada año
Intensivo con ABS	Cada 8 meses

- Preferentemente utilice un tanque de purga (boya) convencional o eléctrica a presión, o una bomba eléctrica de vacío para asegurar un recambio total del líquido de frenos y una limpieza del sistema.
- Colocar correctamente la tapa del depósito.

Nota: Ver recomendación para un adecuado procedimiento de purga y periodos de recambio de líquido de frenos. Por último y para asegurar que todos los componentes se encuentran adecuadamente instalados y asegurar el correcto funcionamiento del sistema de frenos, realice el manejo del vehículo.



Sección 4 / Section 4
Balata freno de disco

LISTA POR NÚMERO DE PARTE / PART NUMBER LISTING



Sección 4 / Section 4

Balata freno de disco

LISTA POR NÚMERO DE PARTE / PART NUMBER LISTING

NUM DE PARTE Part number	FMSI FMSI	LARGO Length	PAGINA Page	DIBUJO Drawing
728-Z	D52	183.0, 199.0	133	1
728-AZ	D52	183.0, 199.0	133	2
734-Z	D45	76.5	133	3
771-Z	D20	202.4	133	4
776-AZ	D34	178.5, 182.9	134	5
780-Z	D37	89.9	134	6
788-Z	D50	157.5, 183.0	134	7
793-Z	D49	108.8	134	8
794-Z	D57	77.7	135	9
795-Z	D57	77.7	135	10
795-Z1	D161	77.7	135	11
7009-Z	D76	108.0	135	12
7013-Z	D50	157.5, 183.0	136	13
7017-Z	D84	143.5, 153.8	136	14
7019-Z	D86	165.2, 176.8	136	15
7021-Z	D45	76.5	136	16
7027-Z	D91	148.5, 160.0	137	17
7031-Z	D96	61.5	137	18
7046-Z	D113	63.2	137	19
7046-Z1	D146	63.2	137	20
7047-Z	D114	77.7	138	21
7059-Z	D41	58.1	138	22
7069-Z	D137	107.6	138	23
7070-Z	D154	152.5, 123.2	138	24
7070-AZ1	D154	152.5, 123.2	139	25
7070-CZ	D183	126.0, 152.3	139	26
7072-AZ1	D152	132.7, 166.0	139	27
7072-Z	D181	132.7, 166.0	139	28
7072-BZ	D310	132.7, 176.1	140	29
7081-Z	D149	182.8, 205.5	140	30
7082-AZ	D150	142.7, 199.0	140	31
7082-Z	D199	142.7, 199.0	140	32
7084-Z	D153	182.5, 197.5	141	33
7097-Z	D170	151.1	141	34
7106-Z	D179	164.0	141	35
7106-Z1	D257	164.0	141	36
7122-Z	D203	177.0	142	37
7125-Z	D205	159.9, 172.0	142	38
7125-Z1	D249	159.9, 172.0	142	39
7125-AZ	D387	159.9, 172.0	142	40
7127-Z	D207	116.0	143	41
7134-Z	D220	151.1	143	42
7136-Z	D215	126.0, 147.0	143	43
7143-Z	D227	118.9	143	44
7144-Z	D228	87.0	144	45
7153-Z	D242	119.7	144	46
7155-Z	D233	108.5	144	47
7155-Z1	D275	108.5	144	48
7164-Z	D259	159.2, 222.0	145	49
7170-Z	D265	129.8	145	50
7171-Z	D266	129.8	145	51
7178-Z	D273	127.5	145	52
7179-AZ	D269	165.2, 177.3	146	53
7183-Z	F111	138.0	146	54
7183-Z1	D280	138.1	146	55
7183-Z2	D569	138.1	146	56
7186-Z1	D332	107.6	147	57
7188-Z	D285	120.6	147	58
7192-Z	D289	126.0, 142.0	147	59
71X4-Z	F051	99.8	147	60
8256-Z	D1146	99.8	148	61
71X5-Z	F013	140.1	148	62
71Y4-Z	F450	151.4	148	63
7205-Z	D303	142.4	148	64
7209-Z	D280	138.1	149	65
7209-Z1	D569	138.1	149	66
7219-Z	D319	91.8	149	67
7219-Z1	D466	91.8	149	68
7220-Z	D320	127.5	150	69
7222-Z	D324	188.7	150	70

NUM DE PARTE Part number	FMSI FMSI	LARGO Length	PAGINA Page	DIBUJO Drawing
7224-Z	D326	159.9, 169.9	150	71
7228-Z	D333	160.5	150	72
7229-Z	D334	127.5	151	73
7234-Z	D340	87.0	151	74
8309-Z	D1190	162.7, 171.0	151	75
723X-Z	F027	129.7	151	76
723XA-Z	F027	129.7	152	77
7241-Z	D349	127.7	152	78
7242-Z	D350	151.3	152	79
7247-Z	D356	119.7	152	80
7253-Z	D363	127.0	153	81
7259-Z	D368	125.0, 148.0	153	82
7259-Z1	D369	125.0, 148.0	153	83
7260-Z	D370	125.0, 147.1	153	84
7260A-Z	D370MA	125.0, 147.1	154	85
7264-Z	D375	157.4, 182.9	154	86
7265-Z	D376	140.0	154	87
7267-Z	D378	99.6	154	88
7272-Z	D383	107.7	155	89
7286-Z	D396	123.0	155	90
7286-Z3	D1267	123.2	155	91
7290-Z	D401	114.6	155	92
7293-Z	D404	127.3	156	93
7298-Z	D410	119.1	156	94
7298-Z1	D436	119.1	156	95
7298-Z3	D611	119.1	157	96
7299-Z	D411	220.2, 235.4	157	97
8983	D1755	141.2	157	98
72X9-Z	D569	138.1	158	99
7300-Z	D412	170.9	158	100
7303-Z	D415	133.5	158	101
7303-Z1	D512	133.6	159	102
7304-Z	D417	188.7	159	103
7305-Z	D418	103.1	159	104
7308-AZ	D421MA	188.7	160	105
7310-Z	D420	123.2	160	106
7318-Z	D430	136.9	160	107
7318-Z1	D653	136.9	160	108
7318-Z2	D815	136.9	161	109
7320-Z	D433	115.8	161	110
7328-Z1	D398	107.6	161	111
7329-Z1	D700	136.8	161	112
7330-Z	D450	192.0	162	113
7331-Z	D451	107.3	162	114
7335-Z	D340	87.0	162	115
7338-Z	D458	102.2	162	116
7339-Z	D459	125.0, 148.0	163	117
7339A-Z	D459MA	125.0, 148.0	163	118
7342-Z	D462	136.8	163	119
7345-Z	D465	137.8	163	120
7347-Z	D363	127.0	164	121
7353-Z	D473	91.5	164	122
7357-Z	D476	140.8	164	123
7357-Z1	D718	140.8	164	124
7361-Z	D375	157.4, 182.9	165	125
7365-Z	D484	127.6	165	126
7376-Z	D497	127.3	165	127
7378-Z	D499	142.7, 199.0	165	128
7382-Z	D503	148.4	166	129
7384-Z	D505	147.7, 212.7	166	130
7384-Z1	D623	147.7, 212.7	166	131
7385-Z	D506	147.7, 190.6	166	132
7386-Z	D507	127.5	167	133
7387-Z	D508	107.6	167	134
7387-Z2	D714	107.6	167	135
7387-Z3	D814	107.6	167	136
7388-Z	D509	114.5	168	137
7389-Z	D510	108.5	168	138
7390-Z	D511	98.6	168	139
9151-Z	D1926	87.0	168	140

NUM DE PARTE Part number	FMSI FMSI	LARGO Length	PAGINA Page	DIBUJO Drawing
7404-AZ	D522	165.0	169	141
7406-Z	D524	165.0, 172.5	169	142
7410-Z	D529	176.0	169	143
7410-AZ	D593	176.0	169	144
7412-Z	D530	149.4	170	145
7414-Z	D532	107.7	170	146
7418-Z	D536	88.4	170	147
7418-Z1	D537	88.4	170	148
7418-Z3	D1086	88.6	171	149
7421-Z1	D595	105.2	171	150
7424-Z	D544	155.5	171	151
7427-Z	D1042	121.9	171	152
7427-Z1	D1170	123.0	172	153
7427-Z2	D683	123.2	172	154
7428-Z	D549	127.4	172	155
7430-Z	D551	138.7	172	156
7434-Z	D555	156.2	173	157
7434-AZ	D555	156.2	173	158
7435-Z	D556	116.5	173	159
7436-Z	D557	238.0	173	160
7437-Z	D558	151.1	174	161
7438-AZ	D658	133.2	174	162
7438-BZ	D641	133.2	174	163
8284-Z	D1173	104.0	174	164
7441-Z	D562	132.6	175	165
7443-Z	D564	88.5	175	166
7456-Z	D576	188.7	175	167
7459-Z	D579	137.7	175	168
7460-Z	D580	109.4	176	169
7463-Z	D583	131.3	176	170
7464-Z	D584	100.0	176	171
7470-AZ	D591	165.0	176	172
7476-Z	D598	123.6	177	173
7477-Z	D599	114.2	177	174
7478-Z	D600	136.6	177	175
7479-Z	D601	123.6	177	176
7480-Z	D202	152.0, 123.2	178	177
7485-Z	D604	132.8	178	178
7487-Z	D606	116.1	178	179
7488-Z	D607	159.9, 172.0	178	180
7489-Z	D610	94.3	179	181
7493-Z	D617	128.7	179	182
7497-Z1	D948	136.2	179	183
74X6-Z	F041	186.6	179	184
8433-Z	D1321	127.0	180	185
7502-Z	D625	141.0	180	186
7502-AZ	D666	141.0	180	187
7503-Z	D632	194.0	181	188
7504-Z	D627	89.6	181	189
7507-AZ	D477	177.2	181	190
7511-AZ	D633	165.5	181	191
7514-Z	D636	102.1	182	192
7514-Z1	D663	102.1	182	193
7515-Z	D637	131.3	182	194
7518-AZ	D642	165.0	182	195
7524-Z	D627	89.6	183	196
7528-Z	D648	156.2	183	197
7529-Z	D649	151.3	183	198
7530-AZ	D650	177.0	183	199
7531-Z	D651	177.0	184	200
7532-Z	D652	153.8	184	201
7533-Z	D540	105.2	184	202
7535-Z	D655	220.0	184	203
7536-Z	D656	123.6	185	204
7537-Z1	D678	144.5	185	205
7538-Z	D561	99.4	185	206
7541-Z	D661	116.2	185	207
7543-Z	D664	141.0	186	208
7545-AZ	D667	141.0	186	209
7546-Z	D668	108.4	187	210

NUM DE PARTE Part number	FMSI FMSI	LARGO Length	PAGINA Page	DIBUJO Drawing
7547-Z	D669	99.2	187	211
7548-Z	D433	115.8	187	212
7549-Z	D436	119.1	188	213
754X-Z	F059	101.8, 87.9	188	214
7554-Z	D673	148.0, 190.6	188	215
7555-Z	D674	140.3	189	216
7558-Z	D679	165.9	189	217
7559-Z	D680	110.0	189	218
7560-Z	D681	156.3	189	219
7563-Z	D688	141.2	190	220
7566-Z1	D855	158.8	190	221
7569-Z	D694	141.5	190	222
756X-Z	D694	141.5	190	223
7572-Z	D684	118.9	191	224
7573-Z	D465	137.8	191	225
7574-Z	D699	147.9	191	226
7576-Z	D702	188.5	191	227
7578-Z	D704	119.0	192	228
7582-Z	D709	61.5	192	229
7584-Z	D711	142.6	192	230
7584-Z1	D879	142.6	192	231
7585-Z	D579	137.7	193	232
7592-Z	D946	155.3	193	233
7593-Z	D726	166.9	193	234
7594-Z	D727	162.0, 161.5	193	235
7595-Z	D728	127.8	194	236
7596-Z	D729	142.6	194	237
8342-Z	D1221	130.0	194	238
75X6-Z	F093	151.3	194	239
75X9-Z	F062	141.2	195	240
9061-Z	D1830	140.0	195	241
7610-Z	D674	140.3	195	242
7611-Z	D741	116.5	195	243
7614-Z	D709	61.5	196	244
7616-Z	D746	192.0	196	245
7616-Z1	D820	192.0	196	246
7617-Z	D748	165.3	196	247
7618-Z	D749	182.6	197	248
7619-Z	D750	121.3	197	249
7620-Z	D752	162.0	197	250
7623-Z	D730	164.0	197	251
7625-Z1	D824	193.1	198	252
7626-Z	D757	158.6	198	253
7627-Z	D758	188.5	198	254
7628-Z	D760	187.9	198	255
7632-Z	D764	137.8	199	256
7634-Z	D767	152.5, 123.7	199	257
7635-Z	D768	146.2	199	258
7636-Z1	D1032	240.0	199	259
7637-Z	D770	108.2	200	260
7639-Z	D772	119.4	200	261
7644-Z	D777	221.7	200	262
7647-Z	D779	63.7	200	263
7649-Z	D781	150.2	201	264
8661-Z	D1461	104.8	201	265
7652-Z	D784	216.0	201	266
7653-Z	D785	176.8	201	267
7656-Z1	D1506	148.7	202	268
7658-Z	D788	176.8	202	269
7659-Z	D789	125.3, 147.9	202	270
765X-Z	F157	102.6, 108.1	202	271
7660-Z	D790	192.3, 194.4	203	272
7661-Z	D791	139.4, 141.4	203	273
7662-Z	D792	142.5	203	274
7663-Z	D793	139.1	203	275
7664-Z	D794	155.1, 156.3	204	276
7665-Z	D795	122.5	204	277
766X-Z	F186	177.8, 160.0	204	278
766X-AZ	F186	177.8, 160.0	204	279
8308-Z	D1189	156.5	205	280

NUM DE PARTE Part number	FMSI FMSI	LARGO Length	PAGINA Page	DIBUJO Drawing
7670-Z	D798	123.0	205	281
7671-Z	D799	119.3	205	282
7672-AZ	D801	156.2	205	283
7673-Z	D802	188.5	206	284
7674-Z	D803	160.3	206	285
7675-Z	D804	183.3	206	286
7676-Z	D805	163.0	206	287
7677-Z	D655	220.0	207	288
7680-Z	D807	116.5	207	289
7681-Z	D808	94.6	207	290
7681A-Z	D808	94.6	207	291
7687-Z	D812	119.4	208	292
8725-Z	D1516	155.2, 156.2	208	293
768X-AZ	F185	155.2, 156.2	208	294
7690-AZ	D816	178.0	208	295
7690-Z	D816	178.0	209	296
7693-Z	D699A	148.0	209	297
7694-Z	D821	220.0	209	298
7694-Z1	D859	220.0	209	299
7695-Z	D822	116.4	210	300
7697-Z	D825	206.0	210	301
8660-Z	D1460	150.1, 151.3	210	302
8254-Z	D1499	130.7	210	303
76X1A-Z	F128	130.7	211	304
76X3-Z	F134	131.0	211	305
7700-Z	D792	142.5	211	306
7701-Z	D828	99.4	211	307
7702-Z	D829	135.2	212	308
7703-Z	D830	164.1	212	309
7704-Z	D831	112.4	212	310
7706-Z	D833	154.0	212	311
7707-Z	D834	183.6	213	312
7709-Z	D768	146.2	213	313
7709-AZ	D768	146.2	213	314
7710-Z	D687	156.2	213	315
7710-AZ	D687	156.2	214	316
7712-Z	D837	129.9	214	317
7713-Z	D838	87.0	214	318
7715-AZ	D840	156.0	214	319
7716-Z	D841	124.0	215	320
7718-Z	D842	188.5	215	321
7719-Z	D843	156.2	215	322
771X-Z	F204	106.2	215	323
7720-Z	D844	146.6	216	324
7723-Z	D847	117.7	216	325
7725AP-Z	D912	63.5, 77.5	216	326
7725AS-Z	D912	63.5, 77.5	216	327
8257-Z	D1147	124.0	217	328
7730-Z	D853	155.0, 156.2	217	329
7732-Z	D856	146.5	217	330
7733-Z	D857	172.0	217	331
7734-Z	D858	155.5	218	332
7735-Z	D752	162.0	218	333
7738-Z	D862	123.0	218	334
8305-Z	D1187	83.5	218	335
7740-Z	D865	100.8	219	336
7741-Z	D866	144.8	219	337
7742-Z	D867	138.8	219	338
7743-Z	D868	111.5, 91.0	219	339
7744-Z	D869	155.3	220	340
7747-Z	D872	131.0	220	341
7748-Z	D873	64.0	220	342
8334-Z	D1214	151.0	220	343
7752-Z	D1096	188.5	221	344
7754-Z	D877	94.5	221	345
7755-AZ	D877	94.5	221	346
7755-BZ	D877	94.5	221	347
7757-Z	D880	161.5	222	348
7757-AZ	D880	161.5	222	349
7758-Z	D881	140.3	222	350

NUM DE PARTE Part number	FMSI FMSI	LARGO Length	PAGINA Page	DIBUJO Drawing
7759-Z	D882	177.0	222	351
9304-Z	D2005	108.5	223	352
7760-Z	D883	137.5	223	353
7763-Z	D886	87.0	223	354
8310-Z	D1191	168.5	223	355
7774-Z	D897	189	224	356
7775-Z	D898	166.5	224	357
7777-Z	D900	105.5	224	358
7779-Z1	D1035	142.9	224	359
777X-Z	F199	110.0	225	360
7782-Z	D904	114.0	225	361
7783-Z	D815	136.9	225	362
7783-AZ	D815	136.9	225	363
7784-Z	D905	105.5	226	364
7787-Z	D908	131.5	226	365
7788-Z	D909	216.0	226	366
7789-Z	D910	149.0	226	367
778X-Z	F202	95.0	227	368
7790-Z	D911	116.0	227	369
7794-Z1	D913	154.0	227	370
7795-Z	D914	141.5	227	371
7796-Z1	D1111	155.2, 156.5	228	372
7799-Z	D918	155.0, 155.1	228	373
7799-Z1	D1260	155.2	228	374
779X-Z	D350B	151.5	228	375
9141-Z	D1911	165.5	229	376
8288-Z	D350	151.3	229	377
7815-Z	D380	205.0, 264.7	229	378
7820-Z	D919	139.2	229	379
7824-Z	D923	122.5	230	380
7825-Z	D924	131.5	230	381
7827-Z	D926	131.4	230	382
782Y-Z	F369	150.1, 151.3	230	383
7832-Z	D815	136.9	231	384
7834-Z	D931	185.0	231	385
7835-Z	D932	150.0	231	386
7837-Z	D934	210.5	231	387
7838-Z	D935	139.5, 141.5	232	388
7841-Z	D939	140.4	232	389
7842-Z1	D1060	123.1	232	390
7846-Z	D945	157.6	232	391
7847-Z	D781	150.0, 151.3	233	392
7848-Z	D949	164.4	233	393
7848A-Z	D949	164.4	233	394
7849-Z	D950	156.5	233	395
7852-Z	D953	185.0	234	396
7855-Z	D956	124.7	234	397
7856-Z	D957	132.0	234	398
7861-Z	D962	171.5	234	399
7863-Z	D964	140.3	235	400
7863-Z1	D981	140.3	235	401
7864-Z	D965	220.0	235	402
7865-Z	D1077	189.0	235	403
7866-Z	D966	189.0	236	404
7869-Z	D967	166.5	236	405
7870-Z	D969	135.5	236	406
7871-Z	D970	156.5	236	407
7873-Z	D972	155.0, 156.4	237	408
7874-Z	D973	123.0	237	409
7875-Z	D974	172.5	237	410
7876-Z	D830	164.1	237	411
7877-Z	D976	134.5	238	412
7878-Z	D1014	190.0	238	413
7880-Z	D929	137.0	238	414
7881-Z	D974	172.5	238	415
7888-Z	D986	140.1, 141.3	239	416
7891-Z	D989	218.0	239	417
7895-Z	D995	111.5	239	418
7896-Z	D906	143.5	239	419
7898-Z	D997	185.0	240	420

NUM DE PARTE Part number	FMSI FMSI	LARGO Length	PAGINA Page	DIBUJO Drawing
7899-Z	D998	140.3	240	421
8246-Z	D1136	164.4	240	422
8934-Z	D1710	140.0	240	423
8924-Z	D1700	178.2	241	424
9195-Z	D1970	155.1	241	425
7902-Z	D1001	131.7	241	426
7904-Z	D1003	155.3, 156.3	241	427
7907-Z	D881	140.3	242	428
7908-AZ	D978	112.0	242	429
7909-Z	D1006	156.3	242	430
7909B-Z	D1006B	156.3	242	431
7910-Z	D855	158.8	243	432
7911-Z	D1007	190.1	243	433
7915-Z1	D1083	176.0	243	434
7915-Z2	D1392	176.0	243	435
7916-Z	D1012	159.0	244	436
7918-Z	D1015	176.0	244	437
7921-Z	D1018	116.0	244	438
7921A-Z	D1018	116.0	244	439
7926-Z	D1021	116.1	245	440
7927-Z	D1022	177.3	245	441
7932-Z	D1028	118.7	245	442
7937-Z	D1033	113.8	245	443
7939-Z	D1036	104.4	246	444
7939-Z1	D1315	103.9	246	445
7940-Z	D1037	106.0, 85.5	246	446
7943-Z	D1039	167.3	246	447
7945-Z	D1041	142.5	247	448
7947-Z	D1044	155.0, 156.5	247	449
7948-Z	D1045	188.5	247	450
7949-Z	D1046	166.5	247	451
7950-Z	D1047	172.5	248	452
7955-Z	D1051	78.5	248	453
7957-Z1	D1095	123.0	248	454
7958-Z	D1053	109.6	248	455
7961-Z	D1055	146.0	249	456
7962-Z	D1056	150.5	249	457
7963-Z	D1057	101.4	249	458
7965-Z	D1058	183.5	249	459
7967-Z	D1061	155.0, 154.5	250	460
7973-Z	D1067	177.3	250	461
7973-Z1	D1068	177.5	250	462
7973-Z2	D1334	177.3	250	463
7974-Z	D1069	177.4	251	464
7974-Z1	D1333	177.6	251	465
7975-Z	D1070	182.0	251	466
7976-Z	D1071	101.8	251	467
7980-Z	D1075	147.5	252	468
7983-Z	D1078	156.6	252	469
7984-Z	D1079	189.0	252	470
7985-Z	D1080	176.0	252	471
7986-Z	D1081	162.5	253	472
7987-Z	D1082	112.8	253	473
7991-Z	D1084	177.5	253	474
7992-Z	D1085	207.0	253	475
7993-Z	D1088	112.8	254	476
7994-Z1	D1521	154.8	254	477
7997-Z	D1092	184.2	254	478
7999-Z	D1093	124.6	254	479
8383-Z	D1268	169.1	255	480
79W3A-Z	F314	169.1	255	481
8432-Z	D1318	165.0	255	482
79W4A-Z	F315	165.0	255	483
7W04-Z	F498	150.3	256	484
7X3-Z	F012	99.2	256	485
8258-Z	D1148	104.00	256	486
8831-Z	D1619	114.7	256	487
7X48-Z	F126	63.6	257	488
735-Z	D30	55.6	257	489
8247-Z	D1137	129.8	257	490

NUM DE PARTE Part number	FMSI FMSI	LARGO Length	PAGINA Page	DIBUJO Drawing
7X54-Z	D298	151.2	257	491
7X54-AZ	D298	151.2	258	492
7X54A-Z	D298	151.2	258	493
7X56-Z	F103	144.9	258	494
7X59-Z	F015	104.9	258	495
7612-Z	D742	130.0	259	496
7729-Z	D852	130.0	259	497
7177-Z	D227	118.9	259	498
7X83-Z	D569	138.1	259	499
8255-Z	D1145	129.0	260	500
8253-Z	D1142	104.5	260	501
8290-Z	D1176	131.5	260	502
7Y06-Z	F219	155.0, 156.5	260	503
7Y08-Z	F221	131.5	261	504
8289-Z	D1175	150.1	261	505
7Y10-Z	F232	155.0, 156.4	261	506
7Y10A-Z	F232	155.0, 156.4	261	507
7Y13-Z	F244	155.0, 156.3	262	508
7Y14-Z	F245	137.0	262	509
8311-Z	D1193	135.0	262	510
7Y21-Z	F253	136.8	262	511
8553-Z	D1435	116.3	263	512
8455-Z	D1344	145.1	263	513
7Y31-Z	F235	61.8	263	514
8336-Z	D1216	95.6	263	515
7Y35-Z	F278	153.6	264	516
7Y43-Z	F317	164.8	264	517
8736-Z	D1528	164.8	264	518
8671-Z	D1471	126.8	264	519
8815-Z	D1601	116.1	265	520
7Y46-Z	F338	122.8	265	521
8701-Z	D1502	122.8	265	522
7Y49-Z	F324	102.9, 108.3	265	523
8728-Z	D1519	155.6	266	524
8775-Z	D1566	164.6	266	525
8780-Z	D1571	136.9	266	526
8781-Z	D1572	102.2	266	527
7Y55-Z	F533	150.4, 151.3	267	528
8827-Z	D1614	108.5	267	529
8926-Z	D1702	14.2	267	530
7Y81-Z	F327	94.4	267	531
7Y84-Z	F262	156.3	268	532
7Y84A-Z	F262	156.3	268	533
8748-Z	D1540	169.2	268	534
7Y87-Z	F222	137.0	268	535
8674-Z	D1475	131.0	269	536
8456-Z	D1345	144.3	269	537
8200-Z	D1094	163.4	296	538
8204-Z	D1101	110.3	269	539
8206-Z	D1100	110.5	270	540
8207-Z	D922	122.6	270	541
8208-Z	D1102	157.7	270	542
8209-Z	D1103	112.8	270	543
8212-Z	D1107	155.2, 156.5	271	544
8213-Z	D1108	105.3	271	545
8214-Z	D1109	140.3	271	546
8218-Z	D1114	110.3	271	547
8220-Z	D915	155.2, 156.2	272	548
8221-Z	D888	157.2	272	549
8225-Z	D1119	134.4	272	550
8226-Z	D1120	144.8	272	551
8231-Z	D1124	110.3	273	552
8238-Z	D1129	131.7	273	553
8259-Z	D1149	139.5	273	554
8266-Z	D1156	130.0	273	555
8267-Z	D1157	93.1	274	556
8268-Z	D1158	195.0	274	557
8269-Z	D1159	163.0	274	558
8270-Z	D1160	118.7	274	559
8272-Z	D1161	110.5	275	560

NUM DE PARTE Part number	FMSI FMSI	LARGO Length	PAGINA Page	DIBUJO Drawing
8277-Z	D1164	136.5	275	561
8282-Z	D1169	178.0	275	562
8292-Z	D1057	101.4	275	563
8295-Z	D1179	122.5	276	564
8297-Z	D1181	176.0	276	565
8300-Z	D1183	176.0	276	566
8301-Z	D1184	122.5	276	567
8307-Z	D1188	138.0	277	568
8312-Z	D1194	142.0	277	569
8314-Z	D462	136.8	277	570
8315-Z	D1195	136.5	277	571
8320-Z	D1200	150.2, 151.4	278	572
8324-Z	D1204	131.4	278	573
8330-Z	D1210	139.0	278	574
8331-Z	D1211	146.5	278	575
8331-Z2	D1293	157.4	279	576
8332-Z	D1212	96.5	279	577
8333-Z	D1213	136.9	279	578
8338-Z	D866	144.8	279	579
8357-Z	D1305	155.1, 156.3	280	580
8362A-Z	D1245	162.4	280	581
8366-Z	D1014	190.0	280	582
8377-Z	D1258	138.7	280	583
8378-Z	D1259	110.5	281	584
8380-Z	D1263	131.8	281	585
8381-Z	D1264	149.2	281	586
8385-Z	D1269	133.1	281	587
8389-Z	D1273	146.6	282	588
8390-Z	D1274	116.5	282	589
8391-Z	D1275	110.6	282	590
8392-Z	D1276	148.7	282	591
8393-Z	D1277	86.6	283	592
8394-Z	D1278	234.2, 235.3	283	593
8395-Z	D1279	166.0	283	594
8396-Z	D1280	169.8	283	595
8397-Z	D1281	113.1	284	596
8403-Z	D1286	169.7	284	597
8403-Z1	D1509	169.7	284	598
8405-Z	D1288	105.4	284	599
8410-Z	D1169	178.0	285	600
8411-Z	D1294	170.8, 169.9	285	601
8419-Z	D1303	143.5	285	602
8420-Z	D1304	116.1	285	603
8421-Z	D1306	155.1, 156.2	286	604
8422-Z	D1307	106.0	286	605
8423-Z	D1308	131.3	286	606
8424-Z	D1309	95.2	286	607
8428-Z5	D1812	99.7	287	608
8428-Z6	D1813	99.7	287	609
8430A-Z	D1316	163.1	287	610
8431A-Z	D1317	136.8	287	611
8434A-Z	D1322	187.8	288	612
8436-Z	D1324	166.6	288	613
8437-Z	D1325	113.2	288	614
8438-Z	D1326	116.1	288	615
8440-Z	D1328	213.8	289	616
8441-Z	D1329	202.1	289	617
8442-Z	D1330	201.8	289	618
8445-Z	D1047	172.5	289	619
8446-Z	D1335	244.3	290	620
8447-Z	D1336	93.3	290	621
8449-Z1	D1374	142.1	290	622
8449-Z2	D1737	141.2	290	623
8450-Z	D1339	161.0	291	624
8451-Z	D1340	146.0	291	625
8452-Z	D1341	122.7	291	626
8453-Z	D1342	188.0	291	627
8454-Z	D784	216.0	292	628
8463-Z1	D1423	98.5	292	629
8466-Z	D1357	131.6	292	630

NUM DE PARTE Part number	FMSI FMSI	LARGO Length	PAGINA Page	DIBUJO Drawing
8468-Z	D1359	155.0	292	631
8470-Z	D1361	154.9, 156.1	293	632
8472-Z	D1363	184.2	293	633
8477-Z	D1368	86.6	293	634
8481-Z	D1327	146.6	293	635
8483-Z	D1371	162.9	294	636
8484-Z	D1372	86.8	294	637
8486A-Z	D1375	154.9	294	638
8488-Z	D1377	116.5	294	639
8489-Z	D1379	124.6	295	640
8494-Z	D1386	116.4	295	641
84X0-Z	F368	148.1	295	642
8668-Z	D1468	116.6	295	643
84X8-Z	F387	99.7	296	644
8776-Z	D1567	143.5	296	645
8500-Z	D1391	115.0	296	646
8501-Z	D1393	105.4	296	647
8502-Z	D1394	136.2	297	648
8507-Z	D1399	214.4	297	649
8508-Z	D1400	194.5	297	650
8512-Z	D1404	141.8	297	651
8513-Z	D1405	189.8	298	652
8523-Z	D1411	202.0	298	653
8525-Z	D1412	193.1, 194.3	298	654
8528-Z	D1414	194.3	298	655
8536-Z	D1421	131.4	299	656
8538-Z	D1184	122.5	299	657
8547-Z	D1430	106.2	299	658
8550-Z	D1433	106.2	299	659
8555-Z	D1437	131.4	300	660
8575-Z	D1439	116.8	300	661
8614-Z	D1295	137.6	300	662
8615-Z	D1447	129.8	300	663
8642-Z	D1452	209.5	301	664
8643-Z	D1453	187.5	301	665
8652-Z	D1334	177.3	301	666
8653-Z	D1454	125.6	301	667
8655-Z	D1455	193.2, 194.3	302	668
8656-Z	D1456	109.2	302	669
8667-Z	D1467	148.1	302	670
8672-Z	D1473	106.0	302	671
8698-Z	D1498	140.0, 141.3	303	672
8922-Z	D1696	151.0	303	673
86X4-Z	F376	103.8	303	674
8703-Z	D1327	146.6	303	675
8711-Z	D1451	93.5	304	676
8715-Z	D1508	195.2	304	677
8731-Z	D1523	140.0	304	678
8738-Z	D1454	125.6	304	679
8760-Z	D1107	155.2, 156.5	305	680
8767-Z	D1555	164.8	305	681
8768-Z	D1556	142.0	305	682
8772-Z	D1561	148.1	305	683
8777-Z	D1568	151.3	306	684
8778-Z	D1569	95.5	306	685
8800-Z	D1589	183.0	306	686
8801-Z	D1590	133.1	306	687
8807-Z	D1259	110.5	307	688
8810-Z	D1595	117.6	307	689
8811-Z	D1596	130.0	307	690
8816-Z	D1602	148.8	307	691
8822-Z1	D1609	112.8	308	692
8822-Z2	D1880	112.3	308	693
8823-Z	D1610	123.3, 123.7	308	694
8825-Z	D1612	116.6	308	695
8826-Z	D1613	123.0	309	696
8836-Z	D1623	141.6	309	697
8837-Z	D1624	104.6	309	698
8840-Z2	D1832	148.8	309	699
8840-Z3	D2036	148.8	310	700



Sección 5 / Section 5
Balata freno de disco
LISTA POR FMSI / FMSI LISTING



Sección 5 / Section 5
Balata freno de disco
LISTA POR FMSI / FMSI LISTING

FMSI FMSI num.	NUM DE PARTE Part number	LARGO Length	PAGINA Page	DIBUJO Drawing
D20	771-Z	202.4	133	4
D34	776-AZ	178.5, 182.9	134	5
D37	780-Z	89.9	134	6
D41	7059-Z	58.1	138	22
D45	734-Z	76.5	133	3
D45	7021-Z	76.5	136	16
D49	793-Z	108.8	134	8
D50	788-Z	157.5, 183.0	134	7
D50	7013-Z	157.5, 183.0	136	13
D52	728-AZ	183.0 199.0	133	2
D52	728-Z	183.0 199.0	133	1
D57	794-Z	77.7	135	9
D57	795-Z	77.7	135	10
D76	7009-Z	108.0	135	12
D84	7017-Z	143.5, 153.8	136	14
D86	7019-Z	165.2, 176.8	136	15
D91	7027-Z	148.5, 160.0	137	17
D96	7031-Z	61.5	137	18
D113	7046-Z	63.2	137	19
D114	7047-Z	77.7	138	21
D137	7069-Z	107.6	138	23
D146	7046-Z1	63.2	137	20
D149	7081-Z	182.8, 205.5	140	30
D150	7082-AZ	142.7, 199.0	140	31
D152	7072-AZ1	132.7, 166.0	139	27
D153	7084-Z	182.5, 197.5	141	33
D154	7070-Z	152.5, 123.2	138	24
D154	7070-AZ1	152.5, 123.2	139	25
D161	795-Z1	77.7	135	11
D170	7097-Z	151.1	141	34
D179	7106-Z	164.0	141	35
D181	7072-Z	132.7, 166.0	139	28
D183	7070-CZ	126.0, 152.3	139	26
D199	7082-Z	142.7, 199.0	140	32
D202	7480-Z	152.0, 123.2	178	177
D203	7122-Z	177.0	142	37
D205	7125-Z	159.9, 172.0	142	38
D207	7127-Z	116.0	143	41
D215	7136-Z	126.0, 147.0	143	43
D220	7134-Z	151.1	143	42
D227	7143-Z	118.9	143	44
D228	7144-Z	87.0	144	45
D233	7155-Z	108.5	144	47
D242	7153-Z	119.7	144	46
D249	7125-Z1	159.9, 172.0	142	39
D257	7106-Z1	164.0	141	36
D259	7164-Z	159.2, 222.0	145	49
D265	7170-Z	129.8	145	50
D266	7171-Z	129.8	145	51
D269	7179-AZ	165.2, 177.3	146	53
D273	7178-Z	127.5	145	52
D275	7155-Z1	108.5	144	48
D280	7183-Z1	138.1	146	55
D280	7209-Z	138.1	149	65
D285	7188-Z	120.6	147	58
D289	7192-Z	126.0, 142.0	147	59
D298	7X54-Z	151.2	257	491
D298	7X54A-Z	151.2	258	493
D298	7X54-AZ	151.2	258	492
D303	7205-Z	142.4	148	64
D310	7072-BZ	132.7, 176.1	140	29
D319	7219-Z	91.8	149	67
D320	7220-Z	127.5	150	69
D324	7222-Z	188.7	150	70
D326	7224-Z	159.9, 169.9	150	71
D332	7186-Z1	107.6	147	57
D333	7228-Z	160.5	150	72
D334	7229-Z	127.5	151	73
D340	7335-Z	87.0	162	115
D340	7234-Z	87.0	151	74

FMSI FMSI num.	NUM DE PARTE Part number	LARGO Length	PAGINA Page	DIBUJO Drawing
D344	7237-AZ	162.7, 171.0	151	75
D349	7241-Z	127.7	152	78
D350	7242-Z	151.3	152	79
D350	8288-Z	151.3	229	377
D350B	779X-Z	151.5	228	375
D356	7247-Z	119.7	152	80
D363	7347-Z	127.0	164	121
D363	7253-Z	127.0	153	81
D368	7259-Z	125.0, 148.0	153	82
D369	7259-Z1	125.0, 148.0	153	83
D370	7260-Z	125.0, 147.1	153	84
D370MA	7260A-Z	125.0, 147.1	154	85
D375	7361-Z	157.4, 182.9	165	125
D375	7264-Z	157.4, 182.9	154	86
D376	7265-Z	140.0	154	87
D378	7267-Z	99.6	154	88
D380	7815-Z	205.0, 264.7	229	378
D383	7272-Z	107.7	155	89
D387	7125-AZ	159.9, 172.0	142	40
D396	7286-Z	123.0	155	90
D398	7328-Z1	107.6	161	111
D401	7290-Z	114.6	155	92
D404	7293-Z	127.3	156	93
D410	7298-Z	119.1	156	94
D411	7299-Z	220.2, 235.4	157	97
D412	7300-Z	170.9	158	100
D415	7303-Z	133.5	158	101
D417	7304-Z	188.7	159	103
D418	7305-Z	103.1	159	104
D420	7310-Z	123.2	160	106
D421MA	7308-AZ	188.7	160	105
D430	7318-Z	136.9	160	107
D433	7320-Z	115.8	161	110
D433	7548-Z	115.8	187	212
D436	7298-Z1	119.1	156	95
D436	7549-Z	119.1	188	213
D450	7330-Z	192.0	162	113
D451	7331-Z	107.3	162	114
D458	7338-Z	102.2	162	116
D459	7339-Z	125.0, 148.0	163	117
D459MA	7339A-Z	125.0, 148.0	163	118
D462	7342-Z	136.8	163	119
D462	8314-Z	136.8	277	570
D465	7345-Z	137.8	163	120
D465	7573-Z	137.8	191	225
D466	7219-Z1	91.8	149	68
D473	7353-Z	91.5	164	122
D476	7357-Z	140.8	164	123
D477	7507-AZ	177.2	181	190
D484	7365-Z	127.6	165	126
D497	7376-Z	127.3	165	127
D499	7378-Z	142.7, 199.0	165	128
D503	7382-Z	148.4	166	129
D505	7384-Z	147.7, 212.7	166	130
D506	7385-Z	147.7, 190.6	166	132
D507	7386-Z	127.5	167	133
D508	7387-Z	107.6	167	134
D509	7388-Z	114.5	168	137
D510	7389-Z	108.5	168	138
D511	7390-Z	98.6	168	139
D512	7303-Z1	133.6	159	102
D522	7404-AZ	165.0	169	141
D524	7406-Z	165.0, 172.5	169	142
D529	7410-Z	176.0	169	143
D530	7412-Z	149.4	170	145
D532	7414-Z	107.7	170	146
D536	7418-Z	88.4	170	147
D537	7418-Z1	88.4	170	148
D540	7533-Z	105.2	184	202
D544	7424-Z	155.5	171	151

FMSI FMSI num.	NUM DE PARTE Part number	LARGO Length	PAGINA Page	DIBUJO Drawing
D549	7428-Z	127.4	172	155
D551	7430-Z	138.7	172	156
D555	7434-AZ	156.2	173	158
D555	7434-Z	156.2	173	157
D556	7435-Z	116.5	173	159
D557	7436-Z	238.0	173	160
D558	7437-Z	151.1	174	161
D561	7538-Z	99.4	185	206
D562	7441-Z	132.6	175	165
D564	7443-Z	88.5	175	166
D569	7183-Z2	138.1	146	56
D569	7209-Z1	138.1	149	66
D569	7X83-Z	138.1	259	499
D569	72X9-Z	138.1	158	99
D576	7456-Z	188.7	175	167
D579	7459-Z	137.7	175	168
D579	7585-Z	137.7	193	232
D580	7460-Z	109.4	176	169
D583	7463-Z	131.3	176	170
D584	7464-Z	100.0	176	171
D591	7470-AZ	165.0	176	172
D593	7410-AZ	176.0	169	144
D595	7421-Z1	105.2	171	150
D598	7476-Z	123.6	177	173
D599	7477-Z	114.2	177	174
D600	7478-Z	136.6	177	175
D601	7479-Z	123.6	177	176
D604	7485-Z	132.8	178	178
D606	7487-Z	116.1	178	179
D607	7488-Z	159.9, 172.0	178	180
D610	7489-Z	94.3	179	181
D611	7298-Z3	119.1	157	96
D617	7493-Z	128.7	179	182
D623	7384-Z1	147.7, 212.7	166	131
D625	7502-Z	141	180	186
D627	7524-Z	89.6	183	196
D627	7504-Z	89.6	181	189
D632	7503-Z	194	181	188
D633	7511-AZ	165.5	181	191
D636	7514-Z	102.1	182	192
D637	7515-Z	131.3	182	194
D641	7438-BZ	133.2	174	163
D642	7518-AZ	165.0	182	195
D648	7528-Z	156.2	183	197
D649	7529-Z	151.3	183	198
D650	7530-AZ	177.0	183	199
D651	7531-Z	177.0	184	200
D652	7532-Z	153.8	184	201
D653	7318-Z1	136.9	160	108
D655	7677-Z	220.0	207	288
D655	7535-Z	220.0	184	203
D656	7536-Z	123.6	185	204
D658	7438-AZ	133.2	174	162
D661	7541-Z	116.2	185	207
D663	7514-Z1	102.1	182	193
D664	7543-Z	141.0	186	208
D666	7502-AZ	141.0	180	187
D667	7545-AZ	141.0	186	209
D668	7546-Z	108.4	187	210
D669	7547-Z	99.2	187	211
D673	7554-Z	148.0, 190.6	188	215
D674	7555-Z	140.3	189	216
D674	7610-Z	140.3	195	242
D678	7537-Z1	144.5	185	205
D679	7558-Z	165.9	189	217
D680	7559-Z	110.0	189	218
D681	7560-Z	156.3	189	219
D683	7427-Z2	123.2	172	154
D227	7177-Z	118.9	259	498
D684	7572-Z	118.9	191	224

FMSI FMSI num.	NUM DE PARTE Part number	LARGO Length	PAGINA Page	DIBUJO Drawing
D687	7710-Z	156.2	213	315
D687	7710-AZ	156.2	214	316
D688	7563-Z	141.2	190	220
D694	7569-Z	141.5	190	222
D694	756X-Z	141.5	190	223
D699	7574-Z	147.9	191	226
D699A	7693-Z	148.0	209	297
D700	7329-Z1	136.8	161	112
D702	7576-Z	188.5	191	227
D704	7578-Z	119.0	192	228
D709	7582-Z	61.5	192	229
D709	7614-Z	61.5	196	244
D711	7584-Z	142.6	192	230
D714	7387-Z2	107.6	167	135
D718	7357-Z1	140.8	164	124
D726	7593-Z	166.9	193	234
D727	7594-Z	162.0, 161.5	193	235
D728	7595-Z	127.8	194	236
D729	7596-Z	142.6	194	237
D730	7623-Z	164.0	197	251
D741	7611-Z	116.5	195	243
D746	7616-Z	192.0	196	245
D748	7617-Z	165.3	196	247
D749	7618-Z	182.6	197	248
D750	7619-Z	121.3	197	249
D752	7735-Z	162.0	218	333
D752	7620-Z	162.0	197	250
D757	7626-Z	158.6	198	253
D758	7627-Z	188.5	198	254
D760	7628-Z	187.9	198	255
D764	7632-Z	137.8	199	256
D767	7634-Z	152.5, 123.7	199	257
D768	7635-Z	146.2	199	258
D768	7709-AZ	146.2	213	314
D768	7709-Z	146.2	213	313
D770	7637-Z	108.2	200	260
D772	7639-Z	119.4	200	261
D777	7644-Z	221.7	200	262
D779	7647-Z	63.7	200	263
D781	7649-Z	150.2	201	264
D781	7847-Z	150.0, 151.3	233	392
D784	8454-Z	216.0	292	628
D784	7652-Z	216.0	201	266
D785	7653-Z	176.8	201	267
D788	7658-Z	176.8	202	269
D789	7659-Z	125.3, 147.9	202	270
D790	7660-Z	192.3, 194.4	203	272
D791	7661-Z	139.4, 141.4	203	273
D792	7700-Z	142.5	211	306
D792	7662-Z	142.5	203	274
D793	7663-Z	139.1	203	275
D794	7664-Z	155.1, 156.3	204	276
D795	7665-Z	122.5	204	277
D798	7670-Z	123.0	205	281
D799	7671-Z	119.3	205	282
D801	7672-AZ	156.2	205	283
D802	7673-Z	188.5	206	284
D803	7674-Z	160.3	206	285
D804	7675-Z	183.3	206	286
D805	7676-Z	163.0	206	287
D807	7680-Z	116.5	207	289
D808	7681A-Z	94.6	207	291
D808	7681-Z	94.6	207	290
D812	7687-Z	119.4	208	292
D814	7387-Z3	107.6	167	136
D815	7832-Z	136.9	231	384
D815	7318-Z2	136.9	161	109
D815	7783-AZ	136.9	225	363
D815	7783-Z	136.9	225	362
D816	7690-AZ	178.0	208	295

FMSI FMSI num.	NUM DE PARTE Part number	LARGO Length	PAGINA Page	DIBUJO Drawing
D816	7690-Z	178.0	209	296
D820	7616-Z1	192.0	196	246
D821	7694-Z	220.0	209	298
D822	7695-Z	116.4	210	300
D824	7625-Z1	193.1	198	252
D825	7697-Z	206.0	210	301
D828	7701-Z	99.4	211	307
D829	7702-Z	135.2	212	308
D830	7876-Z	164.1	237	411
D830	7703-Z	164.1	212	309
D831	7704-Z	112.4	212	310
D833	7706-Z	154.0	212	311
D834	7707-Z	183.6	213	312
D837	7712-Z	129.9	214	317
D838	7713-Z	87.0	214	318
D840	7715-AZ	156.0	214	319
D841	7716-Z	124.0	215	320
D842	7718-Z	188.5	215	321
D843	7719-Z	156.2	215	322
D844	7720-Z	146.6	216	324
D847	7723-Z	117.7	216	325
D853	7730-Z	155.0, 156.2	217	329
D855	7566-Z1	158.8	190	221
D855	7910-Z	158.8	243	432
D856	7732-Z	146.5	217	330
D857	7733-Z	172.0	217	331
D858	7734-Z	155.5	218	332
D859	7694-Z1	220.0	209	299
D862	7738-Z	123.0	218	334
D865	7740-Z	100.8	219	336
D866	7741-Z	144.8	219	337
D866	8338-Z	144.8	279	579
D867	7742-Z	138.8	219	338
D868	7743-Z	111.5, 91.0	219	339
D869	7744-Z	155.3	220	340
D872	7747-Z	131.0	220	341
D873	7748-Z	64.0	220	342
D877	7755-AZ	94.5	221	346
D877	7755-BZ	94.5	221	347
D877	7754-Z	94.5	221	345
D879	7584-Z1	142.6	192	231
D880	7757-AZ	161.5	222	349
D880	7757-Z	161.5	222	348
D881	7758-Z	140.3	222	350
D881	7907-Z	140.3	242	428
D882	7759-Z	177.0	222	351
D883	7760-Z	137.5	223	353
D886	7763-Z	87.0	223	354
D888	8221-Z	157.2	272	549
D897	7774-Z	189.0	224	356
D898	7775-Z	166.5	224	357
D900	7777-Z	105.5	224	358
D904	7782-Z	114.0	225	361
D905	7784-Z	105.5	226	364
D906	7896-Z	143.5	339	419
D908	7787-Z	131.5	226	365
D909	7788-Z	216.0	226	366
D910	7789-Z	149.0	226	367
D911	7790-Z	116.0	227	369
D912	7725AS-Z	63.5, 77.5	216	327
D912	7725AP-Z	63.5, 77.5	216	326
D913	7794-Z1	154.0	227	370
D914	7795-Z	141.5	227	371
D915	8220-Z	155.2, 156.2	272	548
D918	7799-Z	155.0, 155.1	228	373
D919	7820-Z	139.2	229	379
D922	8207-Z	122.6	270	541
D923	7824-Z	122.5	230	380
D924	7825-Z	131.5	230	381
D926	7827-Z	131.4	230	382

FMSI FMSI num.	NUM DE PARTE Part number	LARGO Length	PAGINA Page	DIBUJO Drawing
D929	7880-Z	137.0	238	414
D931	7834-Z	185.0	231	385
D932	7835-Z	150.0	231	386
D934	7837-Z	210.5	231	387
D935	7838-Z	139.5, 141.5	232	388
D939	7841-Z	140.4	232	389
D945	7846-Z	157.6	233	391
D946	7592-Z	155.3	193	233
D948	7497-Z1	136.2	179	183
D949	7848A-Z	164.4	233	394
D949	7848-Z	164.4	233	393
D950	7849-Z	156.5	233	395
D953	7852-Z	185.0	234	396
D956	7855-Z	124.7	234	397
D957	7856-Z	132	234	398
D962	7861-Z	171.5	234	399
D964	7863-Z	140.3	235	400
D965	7864-Z	220.0	235	402
D966	7866-Z	189.0	236	404
D967	7869-Z	166.5	236	405
D969	7870-Z	135.5	236	406
D970	7871-Z	156.5	236	407
D972	7873-Z	155.0, 156.4	237	408
D973	7874-Z	123.0	237	409
D974	7881-Z	172.5	238	415
D974	7875-Z	172.5	237	410
D976	7877-Z	134.5	238	412
D978	7908-AZ	112.0	242	429
D981	7863-Z1	140.3	235	401
D986	7888-Z	140.1, 141.3	239	416
D989	7891-Z	218.0	239	417
D995	7895-Z	111.5	239	418
D997	7898-Z	185.0	240	420
D998	7899-Z	140.3	240	421
D1001	7902-Z	131.7	241	426
D1003	7904-Z	155.3, 156.3	241	427
D1006	7909-Z	156.3	242	430
D1006B	7909B-Z	156.3	242	431
D1007	7911-Z	190.1	243	433
D1012	7916-Z	159.0	244	436
D1014	8366-Z	190.0	280	582
D1014	7878-Z	190.0	238	413
D1015	7918-Z	176.0	244	437
D1018	7921A-Z	116.0	244	439
D1018	7921-Z	116.0	244	438
D1021	7926-Z	116.1	245	440
D1022	7927-Z	177.3	245	441
D1028	7932-Z	118.7	245	442
D1032	7636-Z1	240.0	199	259
D1033	7937-Z	113.8	245	443
D1035	7779-Z1	142.9	224	359
D1036	7939-Z	104.4	246	444
D1037	7940-Z	106.0, 85.5	246	446
D1039	7943-Z	167.3	246	447
D1041	7945-Z	142.5	247	448
D1042	7427-Z	121.9	171	152
D1044	7947-Z	155.0, 156.5	247	449
D1045	7948-Z	188.5	247	450
D1046	7949-Z	166.5	247	451
D1047	7950-Z	172.5	248	452
D1047	8445-Z	172.5	289	619
D1051	7955-Z	78.5	248	453
D1053	7958-Z	109.6	248	455
D1055	7961-Z	146.0	249	456
D1056	7962-Z	150.5	249	457
D1057	7963-Z	101.4	249	458
D1057	8292-Z	101.4	275	563
D1058	7965-Z	183.5	249	459
D1060	7842-Z1	123.1	232	390
D1061	7967-Z	155.0, 154.5	250	460

FMSI FMSI num.	NUM DE PARTE Part number	LARGO Length	PAGINA Page	DIBUJO Drawing
D1067	7973-Z	177.3	250	461
D1068	7973-Z1	177.5	250	462
D1069	7974-Z	177.4	251	464
D1070	7975-Z	182.0	251	466
D1071	7976-Z	101.8	251	467
D1075	7980-Z	147.5	252	468
D1077	7865-Z	189.0	235	403
D1078	7983-Z	156.6	252	469
D1079	7984-Z	189.0	252	470
D1080	7985-Z	176.0	252	471
D1081	7986-Z	162.5	253	472
D1082	7987-Z	112.8	253	473
D1083	7915-Z1	176.0	243	434
D1084	7991-Z	177.5	253	474
D1085	7992-Z	207.0	253	475
D1086	7418-Z3	88.6	171	149
D1088	7993-Z	112.8	254	476
D1092	7997-Z	184.2	254	478
D1093	7999-Z	124.6	254	479
D1094	8200-Z	163.4	296	538
D1095	7957-Z1	123.0	248	454
D1096	7752-Z	188.5	221	344
D1100	8206-Z	110.5	270	540
D1101	8204-Z	110.3	269	539
D1102	8208-Z	157.7	270	542
D1103	8209-Z	112.8	270	543
D1107	8212-Z	155.2, 156.5	271	544
D1107	8760-Z	155.2, 156.5	305	680
D1108	8213-Z	105.3	271	545
D1109	8214-Z	140.3	271	546
D1111	7796-Z1	155.2, 156.5	228	372
D1114	8218-Z	110.3	271	547
D1119	8225-Z	134.4	272	550
D1120	8226-Z	144.8	272	551
D1124	8231-Z	110.3	273	552
D1129	8238-Z	131.7	273	553
D1149	8259-Z	139.5	273	554
D1156	8266-Z	130.0	273	555
D1157	8267-Z	93.1	274	556
D1158	8268-Z	195.0	274	557
D1159	8269-Z	163.0	274	558
D1160	8270-Z	118.7	274	559
D1161	8272-Z	110.5	275	560
D1164	8277-Z	136.5	275	561
D1169	8282-Z	178.0	275	562
D1169	8410-Z	178.0	285	600
D1170	7427-Z1	123.0	172	153
D1179	8295-Z	122.5	276	564
D1179	9008-Z	104.0	321	744
D1181	8297-Z	176.0	276	565
D1183	8300-Z	176.0	276	566
D1184	8538-Z	122.5	299	657
D1184	8301-Z	122.5	276	567
D1188	8307-Z	138.0	277	568
D1194	8312-Z	142.0	277	569
D1195	8315-Z	136.5	277	571
D1200	8320-Z	150.2, 151.4	278	572
D1204	8324-Z	131.4	278	573
D1210	8330-Z	139.0	278	574
D1211	8331-Z	146.5	278	575
D1212	8332-Z	96.5	279	577
D1213	8333-Z	136.9	279	578
D1245	8362A-Z	162.4	280	581
D1258	8377-Z	138.7	280	583
D1259	8807-Z	110.5	309	688
D1259	8378-Z	110.5	281	584
D1260	7799-Z1	155.2	228	374
D1263	8380-Z	131.8	281	585
D1264	8381-Z	149.2	281	586
D1267	7286-Z3	123.2	155	91

FMSI FMSI num.	NUM DE PARTE Part number	LARGO Length	PAGINA Page	DIBUJO Drawing
D1269	8385-Z	133.1	281	587
D1273	8389-Z	146.6	282	588
D1274	8390-Z	116.5	282	589
D1275	8391-Z	110.6	282	590
D1276	8392-Z	148.7	282	591
D1277	8393-Z	86.6	283	592
D1278	8394-Z	234.2, 235.3	283	593
D1279	8395-Z	166.0	283	594
D1280	8396-Z	169.8	283	595
D1281	8397-Z	113.1	284	596
D1286	8403-Z	169.7	284	597
D1288	8405-Z	105.4	284	599
D1293	8331-Z2	157.4	279	576
D1294	8411-Z	170.8, 169.9	285	601
D1295	8614-Z	137.6	300	662
D1303	8419-Z	143.5	285	602
D1304	8420-Z	116.1	285	603
D1305	8357-Z	155.1, 156.3	280	580
D1306	8421-Z	155.1, 156.2	286	604
D1307	8422-Z	106.0	286	605
D1308	8423-Z	131.3	286	606
D1309	8424-Z	95.2	286	607
D1315	7939-Z1	103.9	246	445
D1316	8430A-Z	163.1	287	610
D1317	8431A-Z	136.8	287	611
D1322	8434A-Z	187.8	288	612
D1324	8436-Z	166.6	288	613
D1325	8437-Z	113.2	288	614
D1326	8438-Z	116.1	288	615
D1327	8703-Z	146.6	303	675
D1327	8481-Z	146.6	293	635
D1328	8440-Z	213.8	289	616
D1329	8441-Z	202.1	289	617
D1330	8442-Z	201.8	289	618
D1333	7974-Z1	177.6	251	465
D1334	7973-Z2	177.3	250	463
D1334	8652-Z	177.3	301	666
D1335	8446-Z	244.3	290	620
D1336	8447-Z	93.3	290	621
D1339	8450-Z	161.0	291	624
D1340	8451-Z	146.0	291	625
D1341	8452-Z	122.7	291	626
D1342	8453-Z	188.0	291	627
D1357	8466-Z	131.6	292	630
D1359	8468-Z	155	292	631
D1361	8470-Z	154.9, 156.1	293	632
D1363	8472-Z	184.2	293	633
D1368	8477-Z	86.6	293	634
D1371	8483-Z	162.9	294	636
D1372	8484-Z	86.8	294	637
D1374	8449-Z1	142.1	290	622
D1375	8486A-Z	154.9	294	638
D1377	8488-Z	116.5	294	639
D1379	8489-Z	124.6	295	640
D1386	8494-Z	116.4	295	641
D1391	8500-Z	115.0	296	646
D1392	7915-Z2	176.0	243	435
D1393	8501-Z	105.4	296	647
D1394	8502-Z	136.2	297	648
D1399	8507-Z	214.4	297	649
D1400	8508-Z	194.5	297	650
D1404	8512-Z	141.8	297	651
D1405	8513-Z	189.8	298	652
D1411	8523-Z	202.0	298	653
D1412	8525-Z	193.1, 194.3	298	654
D1414	8528-Z	194.3	298	655
D1421	8536-Z	131.4	299	656
D1423	8463-Z1	98.5	292	629
D1430	8547-Z	106.2	299	658
D1433	8550-Z	106.2	299	659

FMSI FMSI num.	NUM DE PARTE Part number	LARGO Length	PAGINA Page	DIBUJO Drawing
D1437	8555-Z	131.4	300	660
D1439	8575-Z	116.8	300	661
D1447	8615-Z	129.8	300	663
D1451	8711-Z	93.5	304	676
D1452	8642-Z	209.5	301	664
D1453	8643-Z	187.5	301	665
D1454	8653-Z	125.6	301	667
D1454	8738-Z	125.6	304	679
D1455	8655-Z	193.2, 194.3	302	668
D1456	8656-Z	109.2	302	669
D1467	8667-Z	148.1	302	670
D1473	8672-Z	106.0	302	671
D1490	9017-Z	136.9	322	748
D1498	8698-Z	140.0, 141.3	303	672
D1506	7656-Z1	148.7	202	268
D1508	8715-Z	195.2	304	677
D1509	8403-Z1	169.7	284	598
D1521	7994-Z1	154.8	254	477
D1523	8731-Z	140.0	304	678
D1555	8767-Z	164.8	305	681
D1556	8768-Z	142.0	305	682
D1561	8772-Z	148.1	305	683
D1568	8777-Z	151.3	306	684
D1569	8778-Z	95.5	306	685
D1589	8800-Z	183.0	306	686
D1590	8801-Z	133.1	306	687
D1595	8810-Z	117.6	307	689
D1596	8811-Z	130.0	307	690
D1602	8816-Z	148.8	307	691
D1609	8822-Z1	112.8	308	692
D1610	8823-Z	123.3, 123.7	308	694
D1611	8881-Z	180.0	312	708
D1612	8825-Z	116.6	308	695
D1613	8826-Z	123.0	309	696
D1623	8836-Z	141.6	309	697
D1624	8837-Z	104.6	309	698
D1627	8844-Z	155.2	310	701
D1640	8867-Z	141.1	310	702
D1641	8868-Z	146.0	310	703
D1645	8873-Z	181.3	311	704
D1647	8875-Z	140.8	311	705
D1649	8877-Z	165.5	311	706
D1650	8878-Z	141.7	311	707
D1653	8882-Z	154.9, 155.8	312	709
D1654	8883-Z	148.8	312	710
D1663	8891-Z	131.8	312	711
D1665	8893-Z	123.2	313	712
D1668	8896-Z	180.1	313	713
D1676	8905-Z	194.0	313	714
D1677	8906-Z	151.8	313	715
D1679	8908-Z	101.0	314	717
D1680	8909-Z	213.1	314	718
D1691	8918-Z	193.2	314	719
D1709	8932-Z	166.9	315	720
D1711	8936-Z	140.2	315	721
D1717	8942-Z	155.3	315	722
D1728	8952-Z	142.0	315	723
D1729	8953-Z	101.6	316	724
D1731	8956-Z	91.9, 122.2	316	725
D1734	8958-Z	115.6	316	726
D1736	8906-Z1	151.0	314	716
D1737	8449-Z2	141.2	290	623
D1746	8974-Z	141.6	316	727
D1749	8979-Z	155.2	317	728
D1759	8987-Z	130.8	317	729
D1760	8989-Z	160.1	317	730
D1761	8990-Z	122.9	317	731
D1766	8997-Z	113.2	318	732
D1767	8998-Z	181.1	318	733
D1774	9004-Z	171.6	320	742

FMSI FMSI num.	NUM DE PARTE Part number	LARGO Length	PAGINA Page	DIBUJO Drawing
D1775	9005-Z	136.8	320	743
D1779	9008-Z	104.0	321	745
D1786	9013-Z	136.8	321	746
D1787	9014A-Z	171.7	321	747
D1790	9018-Z	148.8	322	749
D1791	9020-Z	185.6	322	750
D1793	9022-Z	126.7	322	751
D1812	8428-Z5	99.7	287	608
D1813	8428-Z6	99.7	287	609
D1815	9049-Z	132.8	323	753
D1818	9053-Z	193.3	323	754
D1826	9035-Z	137.6	323	752
D1832	8840-Z2	148.8	309	699
D1841	9069-Z	116.5	323	755
D1846	9073-Z	112.3	324	756
D1847	9075-Z	140.7	324	757
D1852	9081-Z	125.7	324	758
D1864	9093-Z	128.8	324	759
D1876	9104-Z	210.1	325	760
D1878	9106-Z	122.4	325	761
D1880	8822-Z	112.3	308	693
D1886	9114-Z	142.0	325	762
D1934	9157-Z	94.0	325	763
D2018	9249-Z	243.3	326	764
D2024	9254-Z	128.8	326	765
D2036	8840-Z3	148.8	310	700
D2037	9268-Z	118.9	326	766
D2038	9269-Z	125.5	326	767
D1137	8247-Z	129.8	257	490
F012	7X3-Z	99.2	256	485
F013	71X5-Z	140.1	148	62
F015	7X59-Z	104.9	258	495
D1190	8309-Z	129.7	152	77
F027	723X-Z	129.7	151	76
D30	735-Z	55.6	257	489
D1755	8983-Z	141.2	157	98
F041	74X6-Z	186.6	179	184
D1146	8256-Z	99.8	148	61
F051	71X4-Z	99.8	147	60
F059	754X-Z	101.8, 87.9	188	214
F062	75X9-Z	141.2	195	240
F093	75X6-Z	151.3	194	239
D1136	8246-Z	164.4	240	422
F103	7X56-Z	144.9	258	494
F111	7183-Z	138	146	54
D1221	8342-Z	130	194	238
D1619	8831-Z	114.7	256	487
F126	7X48-Z	63.6	257	488
F128	76X1A-Z	130.7	211	304
D1499	8254-Z	130.7	210	303
F134	76X3-Z	131	211	305
D1148	8258-Z	104.0	256	486
D1321	8433-Z	127	180	185
D1173	8284-Z	104.0	174	164
F157	765X-Z	102.6, 108.1	202	271
D1460	8660-Z	150.1, 151.3	210	302
D74	7612-Z	130.0	259	496
D852	7729-Z	130.0	259	497
D1516	8725-Z	155.2, 156.2	208	293
F185	768X-AZ	155.2, 156.2	208	294
F186	766X-Z	177.8/160.0	204	278
F186	766X-AZ	177.8/160.0	204	279
D1461	8661-Z	104.8	201	265
D1147	8257-Z	124.0	217	328
D1187	8305-Z	83.5	218	335
D1175	8289-Z	150.1	261	505
D1191	8310-Z	168.5	223	355
F199	777X-Z	110.0	225	360
F202	778X-Z	95.0	227	368
F204	771X-Z	106.2	215	323



Sección 6 / Section 6
Balata freno de disco
LISTA POR DIMENSIÓN / LENGTH LISTING



Sección 6 / Section 6
Balata freno de disco
LISTA POR DIMENSIÓN / LENGTH LISTING

LARGO Length	NUM DE PARTE Part number	FMSI FMSI num.	PAGINA Page	DIBUJO Drawing
14.2	8926-Z	D1702	267	530
55.6	735-Z	D30	257	489
58.1	7059-Z	D41	138	22
61.5	7031-Z	D96	137	18
61.5	7582-Z	D709	192	229
61.5	7614-Z	D709	196	244
61.8	7Y31-Z	F235	263	514
63.2	7046-Z	D113	137	19
63.2	7046-Z1	D146	137	20
63.5, 77.5	7725AS-Z	D912	216	327
63.5, 77.5	7725AP-Z	D912	216	326
63.6	7X48-Z	F126	257	488
63.7	7647-Z	D779	200	263
64.0	7748-Z	D873	220	342
76.5	734-Z	D45	133	3
76.5	7021-Z	D45	136	16
77.7	794-Z	D57	135	9
77.7	795-Z	D57	135	10
77.7	7047-Z	D114	138	21
77.7	795-Z1	D161	135	11
78.5	7955-Z	D1051	248	453
83.5	8305-Z	D1187	218	335
86.6	8393-Z	D1277	383	592
86.6	8477-Z	D1368	293	634
86.8	8484-Z	D1372	294	637
87.0	7144-Z	D228	144	45
87.0	7335-Z	D340	162	115
87.0	7234-Z	D340	151	74
87.0	7713-Z	D838	214	318
87.0	7763-Z	D886	223	354
87.0	9151-Z	D1926	168	140
88.4	7418-Z	D536	170	147
88.4	7418-Z1	D537	170	148
88.5	7443-Z	D564	175	166
88.6	7418-Z3	D1086	171	149
89.6	7524-Z	D627	183	196
89.6	7504-Z	D627	181	189
89.9	780-Z	D37	134	6
91.5	7353-Z	D473	164	122
91.8	7219-Z	D319	149	67
91.8	7219-Z1	D466	149	68
91.9, 122.2	8956-Z	D1731	316	725
93.1	8267-Z	D1157	274	556
93.3	8447-Z	D1336	290	621
93.5	8711-Z	D1451	304	676
94.0	9157-Z	D1934	325	763
94.3	7489-Z	D610	179	181
94.4	7Y81-Z	F327	267	531
94.5	7755-AZ	D877	221	346
94.5	7755-BZ	D877	221	347
94.5	7754-Z	D877	221	345
94.6	7681A-Z	D808	207	291
94.6	7681-Z	D808	207	290
95.0	778X-Z	F202	227	368
95.2	8424-Z	D1309	286	607
95.5	8778-Z	D1569	306	685
95.6	8336-Z	D1216	263	515
96.5	8332-Z	D1212	279	577
98.5	8463-Z1	D1423	292	629
98.6	7390-Z	D511	168	139
99.2	7547-Z	D669	187	211
99.2	7X3-Z	F012	256	485
99.4	7538-Z	D561	185	206
99.4	7701-Z	D828	211	307
99.6	7267-Z	D378	154	88
99.7	8428-Z5	D1812	287	608
99.7	8428-Z6	D1813	287	609
99.7	84X8-Z	F387	296	644
99.8	8256-Z	D1146	148	61
99.8	71X4-Z	F051	147	60

LARGO Length	NUM DE PARTE Part number	FMSI FMSI num.	PAGINA Page	DIBUJO Drawing
100.0	7464-Z	D584	176	171
100.8	7740-Z	D865	219	336
101.0	8908-Z	D1679	314	717
101.4	7963-Z	D1057	249	458
101.4	8292-Z	D1057	275	563
101.6	8953-Z	D1729	316	724
101.8	7976-Z	D1071	251	467
101.8, 87.9	754X-Z	F059	188	214
102.1	7514-Z	D636	182	192
102.1	7514-Z1	D663	182	193
102.2	7338-Z	D458	162	116
102.2	8781-Z	D1572	666	527
102.6, 108.1	765X-Z	F157	202	271
102.9, 108.3	7Y49-Z	F324	265	523
103.1	7305-Z	D418	159	104
103.8	86X4-Z	F376	303	674
103.9	7939-Z1	D1315	246	445
104.0	9008-Z	D1179	321	744
104.0	9008-Z	D1779	321	745
104.0	8258-Z	D1148	256	486
104.0	8284-Z	D1173	174	164
104.4	7939-Z	D1036	246	444
104.5	8253-Z	D1142	260	501
104.6	8837-Z	D1624	309	698
104.8	8661-Z	D1461	201	265
104.9	7X59-Z	F015	258	495
105.2	7533-Z	D540	184	202
105.2	7421-Z1	D595	171	150
105.3	8213-Z	D1108	271	545
105.4	8405-Z	D1288	284	599
105.4	8501-Z	D1393	296	647
105.5	7777-Z	D900	224	358
105.5	7784-Z	D905	226	364
106.0	8422-Z	D1307	286	605
106.0	8672-Z	D1473	302	671
106.0, 85.5	7940-Z	D1037	246	446
106.2	8547-Z	D1430	299	658
106.2	8550-Z	D1433	299	659
106.2	771X-Z	F204	215	323
107.3	7331-Z	D451	162	114
107.6	7069-Z	D137	138	23
107.6	7186-Z1	D332	147	57
107.6	7328-Z1	D398	161	111
107.6	7387-Z	D508	167	134
107.6	7387-Z2	D714	167	135
107.6	7387-Z3	D814	167	136
107.7	7272-Z	D383	155	89
107.7	7414-Z	D532	170	146
108.0	7009-Z	D76	135	12
108.2	7637-Z	D770	200	260
108.4	7546-Z	D668	187	210
108.5	7155-Z	D233	144	47
108.5	7155-Z1	D275	144	48
108.5	7389-Z	D510	168	138
108.5	9304-Z	D2005	223	352
108.5	8827-Z	D1614	267	529
108.8	793-Z	D49	134	8
109.2	8656-Z	D1456	302	669
109.4	7460-Z	D580	176	169
109.6	7958-Z	D1053	248	455
110.0	7559-Z	D680	189	218
110.0	777X-Z	F199	225	360
110.3	8204-Z	D1101	269	539
110.3	8218-Z	D1114	271	547
110.3	8231-Z	D1124	273	552
110.5	8206-Z	D1100	270	540
110.5	8272-Z	D1161	275	560
110.5	8807-Z	D1259	307	688
110.5	8378-Z	D1259	281	584
110.6	8391-Z	D1275	282	590

LARGO Length	NUM DE PARTE Part number	FMSI FMSI num.	PAGINA Page	DIBUJO Drawing
111.5	7895-Z	D995	239	418
111.5, 91.0	7743-Z	D868	219	339
112.0	7908-AZ	D978	242	429
112.3	9073-Z	D1846	324	756
112.3	8822-Z	D1880	308	693
112.4	7704-Z	D831	212	310
112.8	7987-Z	D1082	253	473
112.8	7993-Z	D1088	254	476
112.8	8209-Z	D1103	270	543
112.8	8822-Z1	D1609	308	692
113.1	8397-Z	D1281	284	596
113.2	8437-Z	D1325	288	614
113.2	8997-Z	D1766	318	732
113.8	7937-Z	D1033	245	443
114.0	7782-Z	D904	225	361
114.2	7477-Z	D599	177	174
114.5	7388-Z	D509	168	137
114.6	7290-Z	D401	155	92
114.7	8831-Z	D1619	256	487
115.0	8500-Z	D1391	296	646
115.6	8958-Z	D1734	316	726
115.8	7320-Z	D433	161	110
115.8	7548-Z	D433	187	212
116.0	7127-Z	D207	143	41
116.0	7790-Z	D911	227	369
116.0	7921A-Z	D1018	244	439
116.0	7921-Z	D1018	244	438
116.1	7487-Z	D606	178	179
116.1	7926-Z	D1021	245	440
116.1	8420-Z	D1304	285	603
116.1	8438-Z	D1326	288	615
116.1	8815-Z	D1601	265	520
116.2	7541-Z	D661	185	207
116.3	8553-Z	D1435	263	512
116.4	7695-Z	D822	210	300
116.4	8494-Z	D1386	295	641
116.5	7435-Z	D556	173	159
116.5	7611-Z	D741	195	243
116.5	7680-Z	D807	207	289
116.5	8390-Z	D1274	288	589
116.5	8488-Z	D1377	294	639
116.5	9069-Z	D1841	323	755
116.6	8825-Z	D1612	308	695
116.6	8668-Z	D1468	295	643
116.8	8575-Z	D1439	300	661
117.6	8810-Z	D1595	307	689
117.7	7723-Z	D847	216	325
118.7	7932-Z	D1028	245	442
118.7	8270-Z	D1160	274	559
118.9	7143-Z	D227	143	44
118.9	7177-Z	D227	259	498
118.9	7572-Z	D684	191	224
118.9	9268-Z	D2037	326	766
119.0	7578-Z	D704	192	228
119.1	7298-Z	D410	156	94
119.1	7298-Z1	D436	156	95
119.1	7549-Z	D436	188	213
119.1	7298-Z3	D611	157	96
119.3	7671-Z	D799	205	282
119.4	7639-Z	D772	200	261
119.4	7687-Z	D812	208	292
119.7	7153-Z	D242	144	46
119.7	7247-Z	D356	152	80
120.6	7188-Z	D285	147	58
121.3	7619-Z	D750	197	249
121.9	7427-Z	D1042	171	152
122.4	9106-Z	D1878	325	761
122.5	7665-Z	D795	204	277
122.5	7824-Z	D923	230	380
122.5	8295-Z	D1179	276	564

LARGO Length	NUM DE PARTE Part number	FMSI FMSI num.	PAGINA Page	DIBUJO Drawing
122.5	8538-Z	D1184	299	657
122.5	8301-Z	D1184	276	567
122.6	8207-Z	D922	270	541
122.7	8452-Z	D1341	291	626
122.8	7Y46-Z	F338	265	521
122.8	8701-Z	D1502	265	522
122.9	8990-Z	D1761	317	731
123.0	7286-Z	D396	155	90
123.0	7670-Z	D798	205	281
123.0	7738-Z	D862	218	334
123.0	7874-Z	D973	237	409
123.0	7957-Z1	D1095	248	454
123.0	7427-Z1	D1170	172	153
123.0	8826-Z	D1613	309	696
123.1	7842-Z1	D1060	232	390
123.2	7310-Z	D420	160	106
123.2	7427-Z2	D683	172	154
123.2	7286-Z3	D1267	155	91
123.2	8893-Z	D1665	313	712
123.3, 123.7	8823-Z	D1610	308	694
123.6	7476-Z	D598	177	173
123.6	7479-Z	D601	177	176
123.6	7536-Z	D656	185	204
124.0	7716-Z	D841	215	320
124.0	8257-Z	D1147	217	328
124.6	7999-Z	D1093	254	479
124.6	8489-Z	D1379	295	640
124.7	7855-Z	D956	234	397
125.0, 147.1	7260-Z	D370	153	84
125.0, 147.1	7260A-Z	D370MA	154	85
125.0, 148.0	7259-Z	D368	153	82
125.0, 148.0	7259-Z1	D369	153	83
125.0, 148.0	7339-Z	D459	163	117
125.0, 148.0	7339A-Z	D459MA	163	118
125.3, 147.9	7659-Z	D789	202	270
125.5	9269-Z	D2038	326	767
125.6	8653-Z	D1454	301	667
125.6	8738-Z	D1454	304	679
125.6	8X53-Z	F520	319	737
125.7	9081-Z	D1852	324	758
126.0, 147.0	7136-Z	D215	143	43
126.0, 142.0	7192-Z	D289	147	59
126.0, 152.3	7070-CZ	D183	139	26
126.7	9022-Z	D1793	322	751
126.8	8671-Z	D1471	264	519
127.0	7347-Z	D363	164	121
127.0	7253-Z	D363	153	81
127.0	74X7-Z	F139	180	185
127.3	7293-Z	D404	156	93
127.3	7376-Z	D497	165	127
127.4	7428-Z	D549	172	155
127.5	7178-Z	D273	145	52
127.5	7220-Z	D320	150	69
127.5	7229-Z	D334	151	73
127.5	7386-Z	D507	167	133
127.6	7365-Z	D484	165	126
127.7	7241-Z	D349	152	78
127.8	7595-Z	D728	194	236
128.7	7493-Z	D617	179	182
128.8	9093-Z	D1864	324	759
128.8	9254-Z	D2024	326	765
129.0	8255-Z	D1145	260	500
129.7	8309-Z	D1190	152	77
129.7	723X-Z	F027	151	76
129.8	7170-Z	D265	145	50
129.8	7171-Z	D266	145	51
129.8	8615-Z	D1447	300	663
129.8	8247-Z	D1137	257	490
129.9	7712-Z	D837	214	317
130.0	8266-Z	D1156	273	555

LARGO Length	NUM DE PARTE Part number	FMSI FMSI num.	PAGINA Page	DIBUJO Drawing
130.0	8811-Z	D1596	307	690
130.0	8342-Z	D1221	194	238
130.0	7612-Z	D74	259	496
130.0	7729-Z	D852	259	497
130.7	8254-Z	F128	211	304
130.7	76X1-Z	D1499	210	303
130.8	8987-Z	D1759	317	729
131.0	7747-Z	D872	220	341
131.0	76X3-Z	F134	211	305
131.0	7Y90-Z	F309	269	536
131.3	7463-Z	D583	176	170
131.3	7515-Z	D637	182	194
131.3	8423-Z	D1308	286	606
131.4	7827-Z	D926	230	382
131.4	8324-Z	D1204	278	573
131.4	8536-Z	D1421	299	656
131.4	8555-Z	D1437	300	660
131.5	7787-Z	D908	226	365
131.5	7825-Z	D924	230	381
131.5	8290-Z	D1176	260	502
131.5	7Y08-Z	F221	261	504
131.6	8466-Z	D1357	292	630
131.7	7902-Z	D1001	241	426
131.7	8238-Z	D1129	273	553
131.8	8380-Z	D1263	281	585
131.8	8891-Z	D1663	312	711
132.0	7856-Z	D957	234	398
132.6	7441-Z	D562	175	165
132.6	9X49-Z	F529	327	769
132.7	8X51-Z	F386	319	736
132.7, 166.0	7072-AZ1	D152	139	27
132.7, 176.1	7072-BZ	D310	140	29
132.7, 166.0	7072-Z	D181	139	28
132.8	7485-Z	D604	178	178
132.8	9049-Z	D1815	323	753
132.8	8X65-Z	F467	319	738
133.1	8385-Z	D1269	281	587
133.1	8801-Z	D1590	306	687
133.2	7438-BZ	D641	174	163
133.2	7438-AZ	D658	174	162
133.5	7303-Z	D415	158	101
133.6	7303-Z1	D512	159	102
134.4	8225-Z	D1119	272	550
134.5	7877-Z	D976	238	412
135.0	8311-Z	D1193	262	510
135.2	7702-Z	D829	212	308
135.5	7870-Z	D969	236	406
136.2	7497-Z1	D948	179	183
136.2	8502-Z	D1394	297	648
136.5	8277-Z	D1164	275	561
136.5	8315-Z	D1195	277	571
136.6	7478-Z	D600	177	175
136.8	7342-Z	D462	163	119
136.8	8314-Z	D462	277	570
136.8	7329-Z1	D700	161	112
136.8	8431A-Z	D1317	287	611
136.8	9005-Z	D1775	320	743
136.8	9013-Z	D1786	321	746
136.8	7Y21-Z	F253	262	511
136.9	7318-Z	D430	160	107
136.9	7318-Z1	D653	160	108
136.9	7832-Z	D815	231	384
136.9	7318-Z2	D815	161	109
136.9	7783-AZ	D815	225	363
136.9	7783-Z	D815	225	362
136.9	8333-Z	D1213	279	578
136.9	9017-Z	D1490	222	748
136.9	8780-Z	D1571	266	526
136.9	9006-Z	D1776	319	739
136.9	8Y30-Z	F466	320	740

LARGO Length	NUM DE PARTE Part number	FMSI FMSI num.	PAGINA Page	DIBUJO Drawing
137.0	7880-Z	D929	238	414
137.0	7Y87-Z	F222	268	535
137.0	7Y14-Z	F245	262	509
137.5	7760-Z	D883	223	353
137.6	8614-Z	D1295	300	662
137.6	9035-Z	D1826	323	752
137.7	7459-Z	D579	175	168
137.7	7585-Z	D579	193	232
137.8	7345-Z	D465	163	120
137.8	7573-Z	D465	191	225
137.8	7632-Z	D764	199	256
138.0	8307-Z	D1188	277	568
138.0	7183-Z	F111	146	54
138.1	7183-Z1	D280	146	55
138.1	7209-Z	D280	149	65
138.1	7183-Z2	D569	146	56
138.1	7209-Z1	D569	149	66
138.1	7X83-Z	D569	259	499
138.1	72X9-Z	D569	158	99
138.7	7430-Z	D551	172	156
138.7	8377-Z	D1258	280	583
138.7	8804-Z	D1592	318	735
138.8	7742-Z	D867	219	338
139.0	8330-Z	D1210	278	574
139.1	7663-Z	D793	203	275
139.2	7820-Z	D919	229	379
139.4, 141.4	7661-Z	D791	203	273
139.5	8259-Z	D1149	273	554
139.5, 141.5	7838-Z	D935	232	388
140.0	7265-Z	D376	154	87
140.0	8731-Z	D1523	304	678
140.0	8934-Z	D1710	240	423
140.0	9061-Z	D1830	195	241
140.0, 141.3	8698-Z	D1498	303	672
140.1	71X5-Z	F013	148	62
140.1, 141.3	7888-Z	D986	239	416
140.2	8936-Z	D1711	315	721
140.3	7555-Z	D674	189	216
140.3	7610-Z	D674	195	242
140.3	7758-Z	D881	222	350
140.3	7907-Z	D881	242	428
140.3	7863-Z	D964	235	400
140.3	7863-Z1	D981	235	401
140.3	7899-Z	D998	240	421
140.3	8214-Z	D1109	271	546
140.4	7841-Z	D939	332	389
140.7	9075-Z	D1847	324	757
140.8	7357-Z	D476	164	123
140.8	7357-Z1	D718	164	124
140.8	8875-Z	D1647	311	705
141.0	7502-Z	D625	180	186
141.0	7543-Z	D664	186	208
141.0	7502-AZ	D666	180	187
141.0	7545-AZ	D667	186	209
141.1	8867-Z	D1640	310	702
141.2	7563-Z	D688	190	220
141.2	8449-Z2	D1737	290	623
141.2	8983-Z	D1755	157	98
141.2	75X9-Z	F062	195	240
141.5	7569-Z	D694	190	222
141.5	756X-Z	D694	190	223
141.5	7795-Z	D914	227	371
141.6	8836-Z	D1623	309	697
141.6	8974-Z	D1746	316	727
141.7	8878-Z	D1650	311	707
141.7	8Y31-Z	F466	320	741
141.8	8512-Z	D1404	297	651
142.0	8312-Z	D1194	277	569
142.0	8768-Z	D1556	305	682
142.0	8952-Z	D1728	315	723

LARGO Length	NUM DE PARTE Part number	FMSI FMSI num.	PAGINA Page	DIBUJO Drawing
142.0	9114-Z	D1886	325	762
142.1	8449-Z1	D1374	290	622
142.4	7205-Z	D303	148	64
142.5	7700-Z	D792	211	306
142.5	7662-Z	D792	203	274
142.5	7945-Z	D1041	247	448
142.6	7584-Z	D711	192	230
142.6	7596-Z	D729	194	237
142.6	7584-Z1	D879	192	231
142.7, 199.0	7378-Z	D499	165	128
142.7, 199.0	7082-AZ	D150	140	31
142.7, 199.0	7082-Z	D199	140	32
142.9	7779-Z1	D1035	224	359
143.5	7896-Z	D906	339	419
143.5	8419-Z	D1303	285	602
143.5	8776-Z	D1567	296	645
143.5, 153.8	7017-Z	D84	136	14
144.3	8456-Z	D1345	269	537
144.5	7537-Z1	D678	185	205
144.8	7741-Z	D866	219	337
144.8	8338-Z	D866	279	579
144.8	8226-Z	D1120	272	551
144.8	9326-Z1	D2058	327	768
144.9	7X56-Z	F103	258	494
145.1	8455-Z	D1344	263	513
146.0	7961-Z	D1055	249	456
146.0	8451-Z	D1340	291	625
146.0	8868-Z	D1641	310	703
146.2	7635-Z	D768	199	258
146.2	7709-AZ	D768	213	314
146.2	7709-Z	D768	213	313
146.5	7732-Z	D856	217	330
146.5	8331-Z	D1211	278	575
146.6	7720-Z	D844	216	324
146.6	8389-Z	D1273	282	588
146.6	8703-Z	D1327	303	675
146.6	8481-Z	D1327	293	635
147.5	7980-Z	D1075	252	468
147.7, 190.6	7385-Z	D506	166	132
147.7, 212.7	7384-Z	D505	166	130
147.7, 212.7	7384-Z1	D623	166	131
147.9	7574-Z	D699	191	226
148.0	7693-Z	D699A	209	297
148.0, 190.6	7554-Z	D673	188	215
148.1	8667-Z	D1467	302	670
148.1	8772-Z	D1561	305	683
148.1	84X0-Z	F368	295	642
148.1	8X30-Z	F391	318	734
148.4	7382-Z	D503	166	129
148.5, 160.0	7027-Z	D91	137	17
148.7	8392-Z	D1276	282	591
148.7	7656-Z1	D1506	202	268
148.8	8816-Z	D1602	307	691
148.8	8883-Z	D1654	312	710
148.8	9018-Z	D1790	322	749
148.8	8840-Z2	D1832	309	699
148.8	8840-Z3	D2036	310	700
149.0	7789-Z	D910	226	367
149.2	8381-Z	D1264	281	586
149.4	7412-Z	D530	170	145
150.0	7835-Z	D932	231	386
150.0, 151.3	7847-Z	D781	333	392
150.1	8289-Z	D1175	261	505
150.1, 151.3	8660-Z	D1460	210	302
150.1, 151.3	782Y-Z	F369	230	383
150.2	7649-Z	D781	201	264
150.2, 151.4	8320-Z	D1200	278	572
150.3	7W04-Z	F498	256	484
150.4, 151.3	7Y55-Z	F533	267	528
150.5	7962-Z	D1056	249	457

LARGO Length	NUM DE PARTE Part number	FMSI FMSI num.	PAGINA Page	DIBUJO Drawing
151.0	8906-Z1	D1736	314	716
151.0	8334-Z	D1214	220	343
151.0	8922-Z	D1696	303	673
151.1	7097-Z	D170	141	34
151.1	7134-Z	D220	143	42
151.1	7437-Z	D558	174	161
151.2	7X54-Z	D298	257	491
151.2	7X54A-Z	D298	258	493
151.2	7X54-AZ	D298	258	492
151.3	7242-Z	D350	152	79
151.3	8288-Z	D350	229	377
151.3	7529-Z	D649	183	198
151.3	8777-Z	D1568	306	684
151.3	75X6-Z	F093	194	239
151.4	71Y4-Z	F450	148	63
151.5	779X-Z	D350B	228	375
151.8	8906-Z	D1677	313	715
152.0, 123.2	7480-Z	D202	178	177
152.5, 123.7	7634-Z	D767	199	257
152.5, 123.2	7070-Z	D154	138	24
152.5, 123.2	7070-AZ1	D154	139	25
153.6	7Y35-Z	F278	264	516
153.8	7532-Z	D652	184	201
154.0	7706-Z	D833	212	311
154.0	7794-Z1	D913	227	370
154.8	7994-Z1	D1521	254	477
154.9	8486A-Z	D1375	294	638
154.9, 155.8	8882-Z	D1653	312	709
154.9, 156.1	8470-Z	D1361	293	632
155.0	8468-Z	D1359	292	631
155.0, 154.5	7967-Z	D1061	250	460
155.0, 155.1	7799-Z	D918	228	373
155.0, 156.2	7730-Z	D853	217	329
155.0, 156.3	7Y13-Z	F244	262	508
155.0, 156.4	7873-Z	D972	237	408
155.0, 156.4	7Y10A-Z	F232	261	507
155.0, 156.4	7Y10-Z	F232	261	506
155.0, 156.5	7947-Z	D1044	247	449
155.0, 156.5	7Y06-Z	F219	260	503
155.1	9195-Z	D1970	241	425
155.1, 156.2	8421-Z	D1306	286	604
155.1, 156.3	7664-Z	D794	204	276
155.1, 156.3	8357-Z	D1305	280	580
155.2	7799-Z1	D1260	228	374
155.2	8844-Z	D1627	310	701
155.2	8979-Z	D1749	317	728
155.2, 156.2	8220-Z	D915	272	548
155.2, 156.2	8725-Z	D1516	208	293
155.2, 156.2	768X-AZ	F185	208	294
155.2, 156.5	8212-Z	D1107	271	544
155.2, 156.5	8760-Z	D1107	305	680
155.2, 156.5	7796-Z1	D1111	228	372
155.3	7744-Z	D869	220	340
155.3	7592-Z	D946	193	233
155.3	8942-Z	D1717	315	722
155.3, 156.3	7904-Z	D1003	241	427
155.5	7424-Z	D544	171	151
155.5	7734-Z	D858	218	332
155.6	8728-Z	D1519	266	524
156.0	7715-AZ	D840	214	319
156.2	7434-AZ	D555	173	158
156.2	7434-Z	D555	173	157
156.2	7528-Z	D648	183	197
156.2	7710-Z	D687	213	315
156.2	7710-AZ	D687	214	316
156.2	7672-AZ	D801	205	283
156.2	7719-Z	D843	215	322
156.3	7560-Z	D681	189	219
156.3	7909-Z	D1006	242	430
156.3	7909B-Z	D1006B	242	431

LARGO Length	NUM DE PARTE Part number	FMSI FMSI num.	PAGINA Page	DIBUJO Drawing
156.3	7Y84-Z	F262	268	532
156.5	7849-Z	D950	233	395
156.5	7871-Z	D970	236	407
156.5	8308-Z	D1189	205	280
156.6	7983-Z	D1078	252	469
157.2	8221-Z	D888	272	549
157.4	8331-Z2	D1293	279	576
157.4, 182.9	7361-Z	D375	165	125
157.4, 182.9	7264-Z	D375	154	86
157.5, 183.0	788-Z	D50	134	7
157.5, 183.0	7013-Z	D50	136	13
157.6	7846-Z	D945	232	391
157.7	8208-Z	D1102	270	542
158.6	7626-Z	D757	198	253
158.8	7566-Z1	D855	190	221
158.8	7910-Z	D855	243	432
159.0	7916-Z	D1012	244	436
159.2, 222.0	7164-Z	D259	145	49
159.9, 172.0	7125-Z	D205	142	38
159.9, 172.0	7125-Z1	D249	142	39
159.9, 172.0	7125-AZ	D387	142	40
159.9, 172.0	7488-Z	D607	178	180
159.9, 169.9	7224-Z	D326	150	71
160.1	8989-Z	D1760	317	730
160.3	7674-Z	D803	206	285
160.5	7228-Z	D333	150	72
161.0	8450-Z	D1339	291	624
161.5	7757-AZ	D880	222	349
161.5	7757-Z	D880	222	348
162.0	7735-Z	D752	218	333
162.0	7620-Z	D752	197	250
162.0, 161.5	7594-Z	D727	193	235
162.4	8362A-Z	D1245	280	581
162.5	7986-Z	D1081	253	472
162.7, 171.0	7237-AZ	D344	151	75
162.9	8483-Z	D1371	294	636
163.0	7676-Z	D805	206	287
163.0	8269-Z	D1159	274	558
163.1	8430A-Z	D1316	287	610
163.4	8200-Z	D1094	296	538
164.0	7106-Z	D179	141	35
164.0	7106-Z1	D257	141	36
164.0	7623-Z	D730	197	251
164.1	7876-Z	D830	237	411
164.1	7703-Z	D830	212	309
164.4	7848A-Z	D949	233	394
164.4	7848-Z	D949	233	393
164.4	8246-Z	D1136	240	422
164.6	8775-Z	D1566	266	525
164.8	8767-Z	D1555	305	681
164.8	7Y43-Z	F317	264	517
164.8	8736-Z	D1528	264	518
165.0	7404-AZ	D522	169	141
165.0	7470-AZ	D591	176	172
165.0	7518-AZ	D642	182	195
165.0	8432-Z	D1318	255	482
165.0	79W4A-Z	F315	255	483
165.0, 172.5	7406-Z	D524	169	142
165.2, 176.8	7019-Z	D86	136	15
165.2, 177.3	7179-AZ	D269	146	53
165.3	7617-Z	D748	196	247
165.5	7511-AZ	D633	181	191
165.5	8877-Z	D1649	311	706
165.5	9141-Z	D1911	229	376
165.9	7558-Z	D679	189	217
166.0	8395-Z	D1279	283	594
166.5	7775-Z	D898	224	357
166.5	7869-Z	D967	236	405
166.5	7949-Z	D1046	247	451
166.6	8436-Z	D1324	288	613

LARGO Length	NUM DE PARTE Part number	FMSI FMSI num.	PAGINA Page	DIBUJO Drawing
166.9	7593-Z	D726	193	234
166.9	8932-Z	D1709	315	720
167.3	7943-Z	D1039	246	447
168.5	776X-Z	F198	223	355
169.1	79W3-Z	F314	255	480
169.1	79W3A-Z	F314	255	481
169.2	8748-Z	D1540	268	534
169.7	8403-Z	D1286	284	597
169.7	8403-Z1	D1509	284	598
169.8	8396-Z	D1280	283	595
170.8, 169.9	8411-Z	D1294	285	601
170.9	7300-Z	D412	158	100
171.5	7861-Z	D962	234	399
171.6	9004-Z	D1774	320	742
171.7	9014A-Z	D1787	321	747
172.0	7733-Z	D857	217	331
172.5	7881-Z	D974	238	415
172.5	7875-Z	D974	237	410
172.5	7950-Z	D1047	248	452
172.5	8445-Z	D1047	289	619
176.0	7410-Z	D529	169	143
176.0	7410-AZ	D593	169	144
176.0	7918-Z	D1015	244	437
176.0	7985-Z	D1080	252	471
176.0	7915-Z1	D1083	243	434
176.0	8297-Z	D1181	276	565
176.0	8300-Z	D1183	276	566
176.0	7915-Z2	D1392	243	435
176.8	7653-Z	D785	201	267
176.8	7658-Z	D788	202	269
177.0	7122-Z	D203	142	37
177.0	7530-AZ	D650	183	199
177.0	7531-Z	D651	184	200
177.0	7759-Z	D882	222	351
177.2	7507-AZ	D477	181	190
177.3	7927-Z	D1022	245	441
177.3	7973-Z	D1067	250	461
177.3	7973-Z2	D1334	250	463
177.3	8652-Z	D1334	301	666
177.4	7974-Z	D1069	251	464
177.5	7973-Z1	D1068	250	462
177.5	7991-Z	D1084	253	474
177.6	7974-Z1	D1333	251	465
177.8, 160.0	766X-Z	F186	204	278
177.8, 160.0	766X-AZ	F186	204	279
178.0	7690-AZ	D816	208	295
178.0	7690-Z	D816	209	296
178.0	8282-Z	D1169	275	562
178.0	8410-Z	D1169	285	600
178.2	8924-Z	D1700	241	424
178.5, 182.9	776-AZ	D34	134	5
180.0	8881-Z	D1611	312	708
180.1	8896-Z	D1668	313	713
181.1	8998-Z	D1767	318	733
181.3	8873-Z	D1645	311	704
182.0	7975-Z	D1070	251	466
182.5, 197.5	7084-Z	D153	141	33
182.6	7618-Z	D749	197	248
182.8, 205.5	7081-Z	D149	140	30
183.0	8800-Z	D1589	306	686
183.0, 199.0	728-AZ	D52	133	2
183.0, 199.0	728-Z	D52	133	1
183.3	7675-Z	D804	206	286
183.5	7965-Z	D1058	249	459
183.6	7707-Z	D834	213	312
184.2	7997-Z	D1092	254	478
184.2	8472-Z	D1363	293	633
185.0	7834-Z	D931	231	385
185.0	7852-Z	D953	234	396
185.0	7898-Z	D997	240	420



Sección 7 / Section 7
Balata freno de tambor

LISTA POR NÚMERO DE PARTE / PART NUMBER LISTING



Sección 7 / Section 7
Balata freno de tambor

LISTA POR NÚMERO DE PARTE / PART NUMBER LISTING

NUM DE PARTE Part number	FMSI FMSI	LARGO Length	PAGINA Page	DIBUJO Drawing
882	S315	9.060" (230.0)	331	1
1666	S995	7.258" (184.4)	331	2
1303	S842	9.936" (252.4)	331	3
1350	S501	8.000" (203.0)	331	4
1353	S495	6.740" (171.2)	332	5
1354	S559	7.090" (180.0)	332	6
1358	S505	10.000" (254.0)	332	7
1358	S804	10.000" (254.0)	332	8
1358	S871	10.000" (254.0)	333	9
1360	S619	10.000" (254.0)	333	10
1364	S576	7.870" (200.0)	333	11
1365	S519	7.870" (200.0)	333	12
1366	S520	8.660" (220.0)	334	13
1370	S524	9.985" (309.1)	334	14
1373	S532	7.090" (180.0)	334	15
1379	S707	7.090" (180.0)	334	16
1381	S607	8.875" (225.4)	335	17
1394	S636	8.860" (225.0)	335	18
1396	S618	9.840" (250.0)	335	19
1397	S589	11.560" (293.6)	335	20
1397	S764	11.560" (293.2)	336	21
1399	S574	10.240" (260.0)	336	22
1665	S994	7.870" (200.0)	336	23
1670-ZV	S999	9.000" (228.6)	336	24
1714-ZV	S1057	11.366" (288.6)	337	25
1404A	S675	10.000" (254.0)	337	26
1407	S721	8.660" (225.0)	337	27
1429	S627	8.660" (220.0)	337	28
1433	S631	11.500" (292.1)	338	29
1437	S984	7.870" (200.0)	338	30
1437	S991	7.870" (200.0)	338	31
1438	S638	7.090" (180.0)	338	32
1440	S641	8.660" (220.0)	339	33
1441	S643	6.770" (172.0)	339	34
1444A	S657	8.660" (220.0)	339	35
1450	S662	7.870" (200.0)	339	36
1450A	S662	7.870" (200.0)	340	37
1450B	S495	7.870" (200.0)	340	38
1452	S665	9.840" (250.0)	340	39
1461	S630	7.870" (200.0)	340	40
1462	S919	9.000" (228.6)	341	41
1473	S689	7.870" (200.0)	341	42
1479	S696	8.000" (203.0)	341	43
1481	S698	7.870" (200.0)	341	44
1481	S716	7.870" (200.0)	342	45
1482	S699	12.600" (320.0)	342	46
1484	S701	7.240" (184.0)	342	47
1484	S745	7.240" (183.8)	342	48
1485TT	S703	9.840" (250.0)	343	49
1485ATT	S714	9.840" (250.0)	343	50
1495	S808	8.000" (203.0)	343	51
1496	S720	9.000" (228.6)	343	52
14Y8	FT032	7.060" (179.4)	344	53
1500	S780	9.840" (250.0)	344	54
1504	S736	9.000" (228.6)	344	55
1506	S738	8.660" (220.0)	344	56
1513	S747	8.000" (203.0)	345	57
1515	S750	7.870" (200.0)	345	58
1515	S801	7.870" (200.0)	345	59
1515	S832	7.870" (200.0)	345	60
1516	S751	9.060" (230.0)	346	61
1517	S752	13.000" (330.2)	346	62
1524	S760	9.000" (228.6)	346	63
1525	S762	8.000" (203.0)	346	64
1525	S779	8.000" (203.0)	347	65
1525	S1034	8.000" (203.2)	347	66
1529	S785	9.000" (228.6)	347	67
1533	S791	7.240" (183.9)	347	68
1535	S795	9.060" (230.0)	348	69
1540	S800	9.000" (228.6)	348	70

NUM DE PARTE Part number	FMSI FMSI	LARGO Length	PAGINA Page	DIBUJO Drawing
1542	S810	9.000" (228.6)	348	71
1543	S803	8.114" (206.1)	348	72
1547	S814	7.850" (199.5)	349	73
1548	S815	11.660" (296.2)	349	74
1556	S824	11.820" (300.2)	349	75
1581	S852	11.030" (280.1)	349	76
1582	FT051	11.656" (296.0)	350	77
1582	S922	11.600" (294.6)	350	78
1583	S855	11.680" (296.7)	350	79
1595	S938	7.080" (180.0)	350	80
1681-ZV	S1012	11.626" (295.3)	351	81
1685	S1016	11.525" (292.7)	351	82
15Y2	S810	8.000" (203.0)	351	83
1480	S814	6.827" (173.4)	351	84
1616	S910	7.980" (202.7)	352	85
1616	S1021	7.980" (202.7)	352	86
1618	S913	7.890" (200.4)	352	87
1621	S917	7.812" (198.4)	352	88
1623	S921	8.980" (228.0)	353	89
1624	S924	8.060" (204.7)	353	90
1629	S936	9.950" (252.7)	353	91
162X	FT122	7.560" (192.0)	353	92
1632	S940	6.330" (160.7)	354	93
1635	S945	9.078" (230.5)	354	94
1641	S954	7.830" (198.8)	354	95
1643	S959	11.552" (293.4)	354	96
1644	S960	11.552" (293.4)	355	97
1654	S979	7.300" (185.4)	355	98
1663	S992	10.000" (254.0)	355	99
1667	S996	11.560" (293.6)	355	100
1674	S1004	8.040" (204.1)	356	101
1680	S1011	8.020" (203.7)	356	102
1689	S1020	8.054" (204.6)	356	103
1694	S1039	8.960" (227.6)	356	104
1695	S1029	8.364" (212.5)	357	105
1713	S1054	9.038" (229.6)	357	106
1708	S1046	11.030" (280.1)	357	107
1709	S1049	11.560" (293.6)	357	108
1717	S1059	7.110" (180.6)	358	109
1722	S1067	7.300" (185.4)	358	110
1734	S1085	8.000" (203.2)	358	111
1X24	FT009	10.000" (254.0)	358	112
1740	S1094	10.262" (260.6)	359	113
1399	S1026	10.186" (258.7)	359	114
1X36	FT117	10.636" (270.2)	359	115
1X44	FT054	11.625" (295.3)	359	116
1X50	FT121	7.110" (180.6)	360	117
1X81	FT024	7.110" (180.6)	360	118
1X89	FT080	6.107" (155.1)	360	119
1Y08	FT025	7.850" (199.5)	360	120
1Y15	FT034	8.060" (204.7)	361	121
1Y16	FT035	7.060" (179.4)	361	122
1Y19	FT040	9.038" (229.6)	361	123
1Y20	FT031	8.000" (203.0)	361	124
1Y21	FT119	6.284" (159.6)	362	125
1Y22	F124	7.850" (199.3)	362	126
1Y25	FT060	7.020" (178.3)	362	127
1Y28	FT038	9.030" (229.3)	362	128
1Y90	FT115	6.900" (175.3)	363	129
1Y97	S589	10.170" (258.3)	363	130
2006	S280	11.000" (279.4)	363	131
2025	S446	11.000" (279.0)	363	132
2042AT	S451	13.000" (330.2)	364	133
2073T	S473	11.160" (183.5)	364	134
2079B	S824	11.960" (303.8)	364	135
2080T	S264	11.030" (280.1)	364	136
2080TT	S264	11.030" (280.1)	365	137
2085	FT022	12.000" (304.8)	365	138
2086	S646	9.020" (229.2)	365	139



Sección 8 / Section 8
Balata freno de tambor
LISTA POR FMSI / FMSI LISTING



Sección 8 / Section 8
Balata freno de tambor
LISTA POR FMSI / FMSI LISTING

FMSI FMSI num.	NUM DE PARTE Part number	LARGO Length	PAGINA Page	DIBUJO Drawing
FT001	2X64	8.228" (209.0)	373	169
S994	1665	7.870" (200.0)	336	23
S995	1666	7.258" (184.4)	331	2
FT009	1X24	10.000" (254.0)	359	113
S993	1664-ZV	8.296" (210.7)	373	171
FT015	2W61	9.936" (252.4)	372	168
FT022	2085	12.000" (304.8)	365	139
FT024	1X81	7.110" (180.6)	360	119
FT025	1Y08	7.850" (199.5)	361	121
FT031	1Y20	8.000" (203.0)	362	125
FT032	14Y8	7.060" (179.4)	344	53
FT034	1Y15	8.060" (204.7)	361	122
FT035	1Y16	7.060" (179.4)	361	123
FT038	1Y28	9.030" (229.3)	363	129
FT040	1Y19	9.038" (229.6)	361	124
S1026	1399	10.186" (258.7)	359	115
S999	1670-ZV	9.000" (228.6)	336	24
FT051	1582	11.656" (296.0)	350	77
S1012	1681-ZV	11.626" (295.3)	351	81
S1016	1685	11.525" (292.7)	351	82
FT054	1X44	11.625" (295.3)	360	117
FT060	1Y25	7.020" (178.3)	362	128
FT080	1X89	6.107" (155.1)	360	120
S814	1480	6.827" (173.4)	351	84
S1057	1714-ZV	11.366" (288.6)	337	25
S1054	1713	9.038" (229.6)	357	106
FT111	2Y20	7.820" (198.6)	373	172
S1094	1740	10.262" (260.6)	359	114
FT115	1Y90	6.900" (175.3)	363	130
FT117	1X36	10.636" (270.2)	359	116
FT118	2X90		373	170
FT119	1Y21	6.284" (159.6)	362	126
FT120	17X8		358	112
FT121	1X50	7.640" (194.0)	360	118
FT122	162X	7.560" (192.0)	353	92
F124	1Y22		362	127
S264	2080T	11.030" (280.1)	365	137
S264	2080TT	11.030" (280.1)	365	138
S280	2006	11.000" (279.4)	363	132
S314	2137	12.000" (304.8)	367	147
S315	882	9.060" (230.0)	331	1
S357	2146AT	12.000" (304.8)	368	150
S358	2140AT	13.000" (330.2)	367	148
S397	8080	9.920" (252.0)	374	173
S406	8123	10.000" (254.0)	374	175
S445	2089T	10.000" (254.0)	366	142
S446	2025	11.000" (279.0)	364	133
S449	2159TT	11.000" (279.0)	368	152
S451	2042AT	13.000" (330.2)	364	134
S452	2157T	13.000" (330.2)	368	151
S473	2073T	11.160" (183.5)	364	135
S495	1353	6.740" (171.2)	332	5
S495	1450B	7.870" (200.0)	340	38
S501	1350	8.000" (203.0)	331	4
S505	1358	10.000" (254.0)	332	7
S514	2117ATT	9.500" (241.3)	367	145
S519	1365	7.870" (200.0)	333	12
S520	1366	8.660" (220.0)	334	13
S524	1370	9.985" (309.1)	334	14
S532	1373	7.090" (180.0)	334	15
S533	8106	8.000" (203.0)	373	172
S538	2168T	9.000" (228.6)	369	155
S552	2165T	8.860" (225.0)	369	154
S553	2164	7.870" (200.0)	369	153
S559	1354	7.090" (180.0)	332	6
S571	2169	10.000" (254.0)	369	156
S574	1399	10.240" (260.0)	336	22
S576	1364	7.870" (200.0)	333	11
S581	2089AT	10.000" (254.0)	366	144
S582	2141AT	11.030" (280.1)	368	149

FMSI FMSI num.	NUM DE PARTE Part number	LARGO Length	PAGINA Page	DIBUJO Drawing
S583	2171T	12.130" (308.0)	370	157
S589	1397	11.560" (293.6)	335	20
S589	1Y97	10.170" (258.3)	363	131
S607	1381	8.875" (225.4)	335	17
S618	1396	9.840" (250.0)	335	19
S619	1360	10.000" (254.0)	333	10
S627	1429	8.660" (220.0)	337	28
S630	1461	7.870" (200.0)	340	40
S631	1433	11.500" (292.1)	338	29
S636	1394	8.860" (225.0)	335	18
S638	1438	7.090" (180.0)	338	32
S641	1440	8.660" (220.0)	339	33
S643	1441	6.770" (172.0)	339	34
S646	2086	9.020" (229.2)	365	140
S647	2086	9.020" (229.2)	366	141
S652	2134BTT	11.000" (279.4)	367	146
S657	1444A	8.660" (220.0)	339	35
S662	1450A	7.870" (200.0)	340	37
S662	1450	7.870" (200.0)	339	36
S665	1452	9.840" (250.0)	340	39
S670	2174TT	10.000" (254.0)	370	158
S675	1404A	10.000" (254.0)	337	26
S689	1473	7.870" (200.0)	341	42
S696	1479	8.000" (203.0)	341	43
S698	1481	7.870" (200.0)	341	44
S699	1482	12.600" (320.0)	342	46
S701	1484	7.240" (184.0)	342	47
S703	1485TT	9.840" (250.0)	343	49
S704	2180T	9.000" (228.6)	370	159
S705	2089AT	10.000" (254.0)	366	143
S707	1379	7.090" (180.0)	334	16
S714	1485ATT	9.840" (250.0)	343	50
S716	1481	7.870" (200.0)	342	45
S720	1496	9.000" (228.6)	343	52
S721	1407	8.660" (225.0)	337	27
S723	2182TT	11.030" (280.1)	371	161
S734	2182T	11.030" (280.1)	370	160
S736	1504	9.000" (228.6)	344	55
S738	1506	8.660" (220.0)	344	56
S745	1484	7.240" (183.8)	342	48
S747	1513	8.000" (203.0)	345	57
S750	1515	7.870" (200.0)	345	58
S751	1516	9.060" (230.0)	346	61
S752	1517	13.000" (330.2)	346	62
S760	1524	9.000" (228.6)	346	63
S761	2187	7.110" (180.6)	371	162
S762	1525	8.000" (203.0)	346	64
S764	1397	11.560" (293.2)	336	21
S771	2192	8.070" (205.0)	371	163
S772	2193	9.530" (242.0)	372	165
S779	1525	8.000" (203.0)	347	65
S780	1500	9.840" (250.0)	344	54
S785	1529	9.000" (228.6)	347	67
S791	1533	7.240" (183.9)	347	68
S795	1535	9.060" (230.0)	348	69
S800	1540	9.000" (228.6)	348	70
S801	1515	7.870" (200.0)	345	59
S803	1543	8.114" (206.1)	348	72
S804	1358	10.000" (254.0)	332	8
S808	1495	8.000" (203.0)	343	51
S810	1542	9.000" (228.6)	348	71
S810	15Y2	8.000" (203.0)	351	83
S812	2202	7.100" (180.3)	372	166
S814	1547	7.850" (199.5)	349	73
S815	1548	11.660" (296.2)	349	74
S824	1556	11.820" (300.2)	349	75
S824	2079B	11.960" (303.8)	364	136
S832	1515	7.870" (200.0)	345	60
S842	1303	9.936" (252.4)	331	3
S852	1581	11.030" (280.1)	349	76



Sección 9 / Section 9
Balata freno de tambor
LISTA POR DIÁMETRO / DIAMETER LISTING



Sección 9 / Section 9
Balata freno de tambor
LISTA POR DIÁMETRO / DIAMETER LISTING

LARGO Length	NUM DE PARTE Part number	FMSI FMSI num.	PAGINA Page	DIBUJO Drawing
6.107" (155.1)	1X89	FT080	360	120
6.330" (160.7)	1632	S940	354	93
6.740" (171.2)	1353	S495	332	5
6.770" (172.0)	1441	S643	339	34
6.827" (173.4)	1480	S814	351	84
6.900" (175.3)	1Y90	FT115	363	130
7.020" (178.3)	1Y25	FT060	362	128
7.060" (179.4)	14Y8	FT032	344	53
7.060" (179.4)	1Y16	FT035	361	123
7.080" (180.0)	1595	S938	350	80
7.090" (180.0)	1373	S532	334	15
7.090" (180.0)	1354	S559	332	6
7.090" (180.0)	1438	S638	338	32
7.090" (180.0)	1379	S707	334	16
7.100" (180.3)	2202	S812	372	166
7.110" (180.6)	1X81	FT024	360	119
7.110" (180.6)	2187	S761	371	162
7.110" (180.6)	1717	S1059	358	109
7.240" (184.0)	1484	S701	342	47
7.240" (183.8)	1484	S745	342	48
7.240" (183.9)	1533	S791	347	68
7.258" (184.4)	1666	S995	331	2
7.300" (185.4)	1654	S979	355	98
7.300" (185.4)	1722	S1067	358	110
7.812" (198.4)	1621	S917	352	88
7.820" (198.6)	2Y20	FT111	373	172
7.830" (198.8)	1641	S954	354	95
7.850" (199.5)	1Y08	FT025	361	121
7.850" (199.5)	1547	S814	349	73
7.870" (200.0)	1665	S994	336	23
7.870" (200.0)	1450B	S495	340	38
7.870" (200.0)	1365	S519	333	12
7.870" (200.0)	2164	S553	369	153
7.870" (200.0)	1364	S576	333	11
7.870" (200.0)	1461	S630	340	40
7.870" (200.0)	1450A	S662	340	37
7.870" (200.0)	1450	S662	339	36
7.870" (200.0)	1473	S689	341	42
7.870" (200.0)	1481	S698	341	44
7.870" (200.0)	1481	S716	342	45
7.870" (200.0)	1515	S750	345	58
7.870" (200.0)	1515	S801	345	59
7.870" (200.0)	1515	S832	345	60
7.870" (200.0)	1437	S984	338	30
7.870" (200.0)	1437	S991	338	31
7.890" (200.4)	1618	S913	352	87
7.980" (202.7)	1616	S910	352	85
7.980" (202.7)	1616	S1021	352	86
8.000" (203.0)	1Y20	FT031	362	125
8.000" (203.0)	1350	S501	331	4
8.000" (203.0)	8106	S533	373	172
8.000" (203.0)	1479	S696	341	43
8.000" (203.0)	1513	S747	345	57
8.000" (203.0)	1525	S762	346	64
8.000" (203.0)	1525	S779	347	65
8.000" (203.0)	1495	S808	343	51
8.000" (203.0)	15Y2	S810	351	83
8.000" (203.2)	1525	S1034	347	66
8.000" (203.2)	1734	S1085	358	111
8.020" (203.7)	1680	S1011	356	102
8.040" (204.1)	1674	S1004	356	101
8.054" (204.6)	1689	S1020	356	103
8.060" (204.7)	1Y15	FT034	361	122
8.060" (204.7)	1624	S924	353	90
8.070" (205.0)	2192	S771	371	163
8.070" (205.0)	2192	S854	371	164
8.114" (206.1)	1543	S803	348	72
8.228" (209.0)	2X64	FT001	373	169
8.296" (210.7)	1664-ZV	S993	373	171
8.364" (212.5)	1695	S1029	357	105

LARGO Length	NUM DE PARTE Part number	FMSI FMSI num.	PAGINA Page	DIBUJO Drawing
8.660" (220.0)	1366	S520	334	13
8.660" (220.0)	1429	S627	337	28
8.660" (220.0)	1440	S641	339	33
8.660" (220.0)	1444A	S657	339	35
8.660" (225.0)	1407	S721	337	27
8.660" (220.0)	1506	S738	344	56
8.860" (225.0)	2165T	S552	369	154
8.860" (225.0)	1394	S636	335	18
8.875" (225.4)	1381	S607	335	17
8.960" (227.6)	1694	S1039	356	104
8.980" (228.0)	1623	S921	353	89
9.000" (228.6)	1670-ZV	S999	336	24
9.000" (228.6)	2168T	S538	369	155
9.000" (228.6)	2180T	S704	370	159
9.000" (228.6)	1496	S720	343	52
9.000" (228.6)	1504	S736	344	55
9.000" (228.6)	1524	S760	346	63
9.000" (228.6)	1529	S785	347	67
9.000" (228.6)	1540	S800	348	70
9.000" (228.6)	1542	S810	348	71
9.000" (228.6)	1462	S919	341	41
9.020" (229.2)	2086	S646	365	140
9.020" (229.2)	2086	S647	366	141
9.030" (229.3)	1Y28	FT038	363	129
9.038" (229.6)	1Y19	FT040	361	124
9.038" (229.6)	1713	S1054	357	106
9.060" (230.0)	882	S315	331	1
9.060" (230.0)	1516	S751	346	61
9.060" (230.0)	1535	S795	348	69
9.078" (230.5)	1635	S945	354	94
9.500" (241.3)	2117ATT	S514	367	145
9.530" (242.0)	2193	S772	372	165
9.840" (250.0)	1396	S618	335	19
9.840" (250.0)	1452	S665	340	39
9.840" (250.0)	1485TT	S703	343	49
9.840" (250.0)	1485ATT	S714	343	50
9.840" (250.0)	1500	S780	344	54
9.920" (252.0)	8080	S397	374	173
9.936" (252.4)	2W61	FT015	372	168
9.936" (252.4)	1303	S842	331	3
9.950" (252.7)	1629	S936	353	91
9.985" (309.1)	1370	S524	334	14
10.000" (254.0)	1X24	FT009	359	113
10.000" (254.0)	8123	S406	374	173
10.000" (254.0)	2089T	S445	366	142
10.000" (254.0)	1358	S505	332	7
10.000" (254.0)	2169	S571	369	156
10.000" (254.0)	2089AT	S581	366	144
10.000" (254.0)	1360	S619	333	10
10.000" (254.0)	2174TT	S670	370	158
10.000" (254.0)	1404A	S675	337	26
10.000" (254.0)	2089AT	S705	366	143
10.000" (254.0)	1358	S804	332	8
10.000" (254.0)	1358	S871	333	9
10.000" (254.0)	1663	S992	355	99
10.170" (258.3)	1Y97	S589	363	131
10.186" (258.7)	1399	S1026	359	115
10.240" (260.0)	1399	S574	336	22
10.262" (260.6)	1740	S1094	359	114
10.636" (270.2)	1X36	FT117	359	116
11.000" (279.4)	2006	S280	363	132
11.000" (279.0)	2025	S446	364	133
11.000" (279.0)	2159TT	S449	368	152
11.000" (279.4)	2134BTT	S652	367	146
11.000" (279.0)	2210T	S1036	372	167
11.030" (280.1)	2080T	S264	365	137
11.030" (280.1)	2080TT	S264	365	138
11.030" (280.1)	2141AT	S582	368	149
11.030" (280.1)	2182TT	S723	371	161
11.030" (280.1)	2182T	S734	370	160



Sección 10 / Section 10
LISTA POR APLICACIÓN / APPLICATION LISTING

Tipo de vehículo	Rango de años	Eje delantero					Eje trasero												
		Numero de balatas delanteras		Tipo de auto motor o freno		Fórmulas FRITEC	Numero de balatas traseras (disco o tambor)		Fórmulas FRITEC										
		Modelo	AÑO Inicio	AÑO Final	Pastilla	Zapata	Características	AZUL	FX	SFC	SHD	Pastilla	Zapata	Características	AZUL	FX	SFC	SHD	FT OW
Armadora ACURA																			
Tipo de vehículo	CL	1997	1999	7345-Z	D465	2.2L					7418-Z	D536							
	CL	1997	1999	7382-Z	D503	3.0L					7418-Z	D536							
	CL	2001	2003	7656-Z1	D1506	3.2L					7418-Z	D536							
	EL	1997	2000	7345-Z	D465						1364	S576							
	ILX	2013	2014	7497-Z1	D948	Hybrid					7418-Z1	D537							
	ILX	2013	2015	7795-Z	D914	2.4L					7418-Z1	D537							
	ILX	2016	2017	8840-Z2	D1832						7418-Z1	D537							
	INTEGRA	1994	2001	7493-Z	D617						7443-Z	D564							
	INTEGRA	1998	2001	7382-Z	D503						7418-Z1	D537							
	LEGEND	1991	1995	7382-Z	D503						7418-Z	D536							
	RL	1996	1999	7382-Z	D503						7418-Z	D536							
	RL	2000	2004	7656-Z1	D1506						7418-Z	D536							
	RSX	2002	2006	7702-Z	D829						7418-Z1	D537							
	TL	2004	2006								7418-Z	D536							
	TL	2005	2008	7656-Z1	D1506	T/A					7418-Z	D536							
	TL	2007	2008								7418-Z	D536							
	TL	2009	2014	8208-Z	D1102						8209-Z	D1103							
	TLX	2015	2017	8208-Z	D1102														
TSX	2004	2008	7656-Z1	D1506						7418-Z1	D537								
TSX	2009	2014	7656-Z1	D1506						8447-Z	D1336								
ACURA TRUCK																			
VIGOR	1992	1994	7382-Z	D503						7418-Z1	D537								
MDX	2001	2006	7663-Z	D793						7740-Z	D865								
MDX	2007	2017	8396-Z	D1280	V6 3.7L					8397-Z	D1281								
RDX	2005	2012	7994-Z1	D1521	AWD					7418-Z	D536								
RDX	2010	2012	7994-Z1	D1521	FWD					7418-Z3	D1086								
RDX	2013	2017								7418-Z3	D1086								
SLX	1996	1999	7459-Z	D579						7460-Z	D580								
ZDX	2010	2013	8396-Z	D1280						8397-Z	D1281								
ALFA ROMEO																			
GTV6	1981	1983	734-Z	D45						7*5-Z	F030								
AMC																			
AMERICAN	1980	1983	7027-Z	D91															
GREMLIN	1980	1981	7027-Z	D91															
GREMLIN	1982	1983	7122-Z	D203															
LERMA	1980	1983	7027-Z	D91															
RALLY	1981	1983	7027-Z	D91															
AUDI																			
80	1988	1992								7144-Z	D228								
90	1984	1995								7144-Z	D228								
100	1992	1994	7434-AZ	D555	Con Sensor de Desgaste					7144-Z	D228								
100	1992	1994	7434-Z	D555	Sin Sensor de Desgaste					7144-Z	D228								
200	1989	1991								7144-Z	D228								
4000	1984	1987	7177-Z	D227						7144-Z	D228								
4000	1985	1987								7144-Z	D228								
5000	1981	1983	7143-Z	D227						7144-Z	D228								
5000	1985	1988								7144-Z	D228								
A1	2011	2017	7635-Z	D768						7335-Z	D340								
A1	2012	2017	8212-Z	D1107	SLine					8213-Z	D1108								
A3	1998	2000	7434-AZ	D555	Con Sensor de Desgaste					7144-Z	D228								
A3	1998	2000	7434-Z	D555	Sin Sensor de Desgaste					7144-Z	D228								
A3	2000	2005	7635-Z	D768						7335-Z	D340								
A3	2001	2004	7709-AZ	D768	Con Sensor de Desgaste					7335-Z	D340								
A3	2001	2004	7709-Z	D768	Sin Sensor de Desgaste					7335-Z	D340								
A3	2004	2005	8212-Z	D1107	Quattro					8213-Z	D1108								
A3	2004	2008	8212-Z	D1107	2.0L / 3.2L C/Sensor					8213-Z	D1108								
A3	2009	2009	7709-AZ	D768	2.0L Turbo					8213-Z	D1108								
A3	2009	2011	8212-Z	D1107						8213-Z	D1108								
A3	2011	2013	8212-Z	D1107						8656-Z	D1456								
A3	2014	2018	8989-Z	D1760	Base, Quattro					8990-Z	D1761								
A4	1997	1999	7434-AZ	D555	C/Sensor Eléctrico / Quattro					7144-Z	D228								
A4	1997	1999	7434-Z	D555	S/Sensor Eléctrico / Quattro					7144-Z	D228								
A4	1999	1999	7710-Z	D687						7335-Z	D340								
A4	1998	2001	7710-AZ	D687	Avant / Quattro					7144-Z	D228								

Para facilitar el manejo de la lista por aplicaciones, recomendamos utilizar nuestro índice general, en donde aparecen las marcas de cada modelo ordenadas alfabéticamente.

MODELO Model	AÑO Inicio	AÑO Final	BALATAS DELANTERAS							BALATAS TRASERAS						
			Pastilla	Zapata	Características	AZUL	FIX	SPC	SHD	Pastilla	Zapata	Características	AZUL	FIX	SPC	SHD
ACURA																
CL	1997	1999	7345-Z	D465	2.2L	•	•	7418-Z	D536		•	•				
CL	1997	1999	7382-Z	D503	3.0L	•	•	7418-Z	D536		•	•				
CL	2001	2003	7656-Z1	D1506	3.2L	•	•	7418-Z	D536		•	•				
EL	1997	2000	7345-Z	D465		•	•	1364	S576		•	•				•
ILX	2013	2014	7497-Z1	D948	Hybrid	•	•	7418-Z1	D537		•	•				
ILX	2013	2015	7795-Z	D914	2.4L	•	•	7418-Z1	D537		•	•				
ILX	2016	2017						7418-Z1	D537		•	•				
INTEGRA	1994	2001	7493-Z	D617		•	•	7443-Z	D564		•	•				
INTEGRA	1998	2001	7382-Z	D503		•	•	7418-Z1	D537		•	•				
LEGEND	1991	1995	7382-Z	D503		•	•	7418-Z	D536		•	•				
RL	1996	1999	7382-Z	D503		•	•	7418-Z	D536		•	•				
RL	2000	2004	7656-Z1	D1506		•	•	7418-Z	D536		•	•				
RSX	2002	2006	7702-Z	D829		•	•	7418-Z1	D537		•	•				
TL	2004	2006						7418-Z	D536		•	•				
TL	2005	2008	7656-Z1	D1506	T/A	•	•	7418-Z	D536		•	•				
TL	2007	2008						7418-Z	D536		•	•				
TL	2009	2014	8208-Z	D1102			•	8209-Z	D1103		•					
TLX	2015	2017	8208-Z	D1102			•									
TSX	2004	2008	7656-Z1	D1506		•	•	7418-Z1	D537		•	•				
TSX	2009	2014	7656-Z1	D1506		•	•	8447-Z	D1336		•	•				
ACURA TRUCK																
VIGOR	1992	1994	7382-Z	D503		•	•	7418-Z1	D537		•	•				
MDX	2001	2006	7663-Z	D793		•	•	7740-Z	D865		•	•				
MDX	2007	2017	8396-Z	D1280	V6 3.7L		•	8397-Z	D1281		•	•				
RDX	2005	2012	7994-Z1	D1521	AWD	•	•	7418-Z	D536		•	•				
RDX	2010	2012	7994-Z1	D1521	FWD	•	•	7418-Z3	D1086		•	•				
RDX	2013	2017						7418-Z3	D1086		•	•				
SLX	1996	1999	7459-Z	D579		•	•	7460-Z	D580		•	•				
ZDX	2010	2013	8396-Z	D1280			•	8397-Z	D1281		•	•				
ALFA ROMEO																
GTV-6	1981	1983	734-Z	D45		•	•	735-Z	F030		•	•				
AMC																
AMERICAN	1980	1983	7027-Z	D91		•	•									
GREMLIN	1980	1981	7027-Z	D91		•	•									
GREMLIN	1982	1983	7122-Z	D203		•	•									
LERMA	1980	1983	7027-Z	D91		•	•									
RALLY	1981	1983	7027-Z	D91		•	•									
AUDI																
100	1992	1994	7434-AZ	D555	Con Sensor de Desgaste	•	•	7144-Z	D228		•	•				
100	1992	1994	7434-Z	D555	Sin Sensor de Desgaste	•	•	7144-Z	D228		•	•				
200	1989	1991						7144-Z	D228		•	•				
4000	1984	1987	7177-Z	D227		•	•	7144-Z	D228		•	•				
4000	1985	1987						7144-Z	D228		•	•				
5000	1981	1983	7143-Z	D227		•	•	7144-Z	D228		•	•				
5000	1985	1988						7144-Z	D228		•	•				
A1	2011	2017	7635-Z	D768		•	•	7335-Z	D340		•	•				
A1	2012	2017	8212-Z	D1107	SLine	•	•	8213-Z	D1108		•	•				
A3	1998	2000	7434-AZ	D555	Con Sensor de Desgaste	•	•	7144-Z	D228		•	•				
A3	1998	2000	7434-Z	D555	Sin Sensor de Desgaste	•	•	7144-Z	D228		•	•				
A3	2000	2005	7635-Z	D768		•	•	7335-Z	D340		•	•				
A3	2001	2004	7709-AZ	D768	Con Sensor de Desgaste	•	•	7335-Z	D340		•	•				
A3	2001	2004	7709-Z	D768	Sin Sensor de Desgaste	•	•	7335-Z	D340		•	•				
A3	2004	2005	8212-Z	D1107	Quattro	•	•	8213-Z	D1108		•	•				
A3	2004	2008	8212-Z	D1107	2.0L / 3.2L C/Sensor	•	•	8213-Z	D1108		•	•				
A3	2009	2009	7709-AZ	D768	2.0L Turbo	•	•	8213-Z	D1108		•	•				
A3	2009	2010	8212-Z	D1107		•	•	8213-Z	D1108		•	•				
A3	2011	2013	8212-Z	D1107		•	•	8656-Z	D1456		•	•				
A3	2014	2018	8989-Z	D1760	Base, Quattro	•	•	8990-Z	D1761		•	•				
A4	1997	1999	7434-AZ	D555	C/Sensor Eléctrico / Quattro	•	•	7144-Z	D228		•	•				
A4	1997	1999	7434-Z	D555	S/Sensor Eléctrico / Quattro	•	•	7144-Z	D228		•	•				
A4	1999	1999	7710-Z	D687		•	•	7335-Z	D340		•	•				
A4	1998	2001	7710-AZ	D687	Avant / Quattro	•	•	7144-Z	D228		•	•				
A4	1999	2002	7715-AZ	D840	Quattro	•	•				•	•				
A4	2000	2001	7710-Z	D687		•	•	7335-Z	D340		•	•				

MODELO Model	AÑO Inicio	AÑO Final	BALATAS DELANTERAS			AZUL	FIX	SFC	SHD	BALATAS TRASERAS			AZUL	FIX	SFC	SHD	FT OW
			Pastilla	Zapata	Características					Pastilla	Zapata	Características					
A4	2002	2005	7715-AZ	D840	Cabriolet / Quattro	.	.		7335-Z	D340		
A4	2005	2006	7715-AZ	D840	Quattro	.	.		8213-Z	D1108		
A4	2005	2009	7796-Z1	D1111	Quattro	.	.		8213-Z	D1108		
A4	2006	2006	7715-AZ	D840	Cabriolet / 1.8L Ø Rotor 245mm / 1.8L Rotor 245 y 255mm	.	.		7234-Z	D340		
A4	2006	2006	7715-AZ	D840	1.8L Ø Rotor 245mm	.	.		7335-Z	D340		
A4	2006	2008	7796-Z1	D1111	Quattro	.	.		7921A-Z	D1018		
A4	2006	2006	7725AS-Z	D912	2.0L Ø Rotor 320mm y 345mm S/Sensor Eléctrico	.	.		8213-Z	D1108		
A4	2006	2006	7725AP-Z	D912	2.0L Ø Rotor 320mm y 345mm C/Sensor Eléctrico	.	.		8213-Z	D1108		
A4	2007	2007	7796-Z1	D1111	Quattro	.	.		7335-Z	D340		
A4	2009	2016	8434A-Z	D1322		.	.		8494-Z	D1386		
A5	2008	2017	8434A-Z	D1322	Base, Quattro, Cabrio	.	.		8494-Z	D1386		
A6	1995	1999	7434-AZ	D555	Con Sensor de Desgaste	.	.		7144-Z	D228		
A6	1996	1999	7434-Z	D555	Sin Sensor de Desgaste	.	.		7144-Z	D228		
A6	1998	1999	7434-AZ	D555	Con Sensor de Desgaste	.	.		7335-Z	D340		
A6	1999	1999	7434-Z	D555	Sin sensor de Desgaste	.	.		7335-Z	D340		
A6	2000	2004	7715-AZ	D840	Quattro	.	.		7335-Z	D340		
A6	2000	2003	7710-Z	D687	S/Sensor eléctrico	.	.		7335-Z	D340		
A6	2003	2003	7710-Z	D687	Quattro S/Sensor eléctrico	.	.		8213-Z	D1108		
A6	2004	2005	7725AP-Z	D912	Caliper Doble Pistón Balata Primaria	.	.		7335-Z	D340		
A6	2004	2005	7725AS-Z	D912	Caliper Doble Pistón Balata Secundaria	.	.		7335-Z	D340		
A6	2005	2005	7715-AZ	D840	Quattro	.	.		7921A-Z	D1018		
A6	2005	2010	7796-Z1	D1111	Quattro	.	.		8213-Z	D1108		
A6	2005	2011	7796-Z1	D1111	Quattro	.	.		7921A-Z	D1018		
A6	2013	2015	8434A-Z	D1322	L4 / Quattro	
A6	2016	2017	8891-Z	D1663	Latinoamerica	
A7	2014	2015	8434A-Z	D1322	TDI / Quattro	
A8	1997	1997	7434-AZ	D555	Con Sensor de Desgaste	.	.		7144-Z	D228		
A8	1997	1997	7434-Z	D555	Sin Sensor de Desgaste	.	.		7144-Z	D228		
A8	1999	2000	7434-AZ	D555	Quattro C/Sensor eléctrico	
A8	1999	2000	7434-Z	D555	Quattro S/Sensor eléctrico	
A8	1999	2000	7710-Z	D687	Quattro	
A8	2000	2003	7715-AZ	D840	Quattro Calipers un pistón	.	.		7335-Z	D340		
A8	2000	2003	7725AP-Z	D912	Quattro Calipers Doble Pistón C/Sensor Eléctrico	.	.		7335-Z	D340		
A8	2003	2003	7725AS-Z	D912	Quattro Calipers Doble Pistón S/Sensor Eléctrico	
A8	2004	2010			Quattro 4.2L / 6.0L C/Sensor Eléctrico	.	.		7921A-Z	D1018		
CABRIOLET	1990	1990			Rotor ventilado	.	.		1354	S559		
CABRIOLET	1991	1993	7183-Z2	D569		.	.		1354	S559		
CABRIOLET	1994	1998				.	.		7144-Z	D228		
COUPE	1981	1982				.	.		1353	S495		
COUPE	1985	1987				.	.		1450A	S662	Diseño Brasileño	
COUPE	1985	1987	7177-Z	D227		.	.		1450A	S662	Diseño Brasileño	
COUPE	1990	1990			Quattro	.	.		7144-Z	D228		
QUATTRO	1985	1985				.	.		7144-Z	D228		
RS6	2003	2004	7715-AZ	D840	Ø Rotor de 312mm	.	.		7921A-Z	D1018		
RS6	2003	2004	7725AS-Z	D912	Ø Rotor de 321mm Calipers Doble Pistón	.	.		7921A-Z	D1018		
RS6	2003	2004			Ø Rotor de 321mm Calipers Un pistón	.	.		7921A-Z	D1018		
S3	2000	2000	7434-AZ	D555	Con Sensor de Desgaste	.	.		7144-Z	D228		
S3	2000	2000	7434-Z	D555	Sin Sensor de Desgaste	.	.		7144-Z	D228		
S3	2001	2001	7710-Z	D687	Quattro	.	.		7144-Z	D228		
S3	2008	2011	8212-Z	D1107	Quattro	.	.		8213-Z	D1108		
S3	2009	2011	8212-Z	D1107	Quattro	.	.		8656-Z	D1456		
S3	2016	2017				.	.		9008-Z	D1779		
S4	1992	1994				.	.		7144-Z	D228		
S4	2000	2002	7725AP-Z	D912	Caliper Doble Pistón C/Sensor	.	.		7335-Z	D340		
S4	2004	2009	7796-Z1	D1111	Quattro	.	.		7921A-Z	D1018		
S4	2010	2015	8434A-Z	D1322		.	.		8494-Z	D1386		
S5	2008	2017	8434A-Z	D1322		.	.		8494-Z	D1386		
S6	1995	1997				.	.		7144-Z	D228		
S6	2001	2004	7725AP-Z	D912	Caliper Doble Pistón C/Sensor	.	.		7335-Z	D340		
S6	2002	2003	7715-AZ	D840	Calipers Un pistón	.	.		7335-Z	D340		
S6	2007	2010				.	.		8213-Z	D1108		
S6	2007	2011				.	.		7921A-Z	D1018		
S8	2007	2009				.	.		7921A-Z	D1018		
SQ5	2014	2017				.	.		8494-Z	D1386		
TT	2000	2007	7710-AZ	D687	Roadster Quattro C/Sensor Eléctrico	.	.		7335-Z	D340		
TT	2000	2007	7710-Z	D687	S/Sensor Eléctrico	.	.		7335-Z	D340		
TT	2008	2013	8212-Z	D1107	Roadster S Quattro	.	.		8213-Z	D1108		
TT	2008	2015	8468-Z	D1359	Quattro Ø Rotor 340mm	.	.		8213-Z	D1108		
TT	2008	2015	8212-Z	D1107	Quattro Ø Rotor 312mm	.	.		8213-Z	D1108		
TT	2016	2017	8989-Z	D1760	Quattro	.	.		8989	D1761		

MODELO Model	AÑO Inicio	AÑO Final	BALATAS DELANTERAS							BALATAS TRASERAS							
			Pastilla	Zapata	Características	AZUL	FIX	SPC	SHD	Pastilla	Zapata	Características	AZUL	FIX	SPC	SHD	FT OW
TT	2016	2017	9104-Z	D1876	S Quattro					8990-Z	D1761						
AUDI TRUCK																	
ALLROAD	2003	2005	7725AP-Z	D912	Quattro Calipers Doble Pistón Balata Primaria	•				7335-Z	D340		•				
ALLROAD	2003	2005	7725AS-Z	D912	Quattro Calipers Doble Pistón Balata Secundaria	•				7335-Z	D340		•				
ALLROAD	2013	2016	8434A-Z	D1322				•		8494-Z	D1386		•				
Q2	2018	2018	8989-Z	D1760				•		8990-Z	D1761		•				
Q3	2015	2017	8486A-Z	D1375	Base, Quattro			•		9008-Z	D1179		•				
Q5	2009	2012	8434A-Z	D1322				•		8494-Z	D1386		•				
Q5	2013	2017	8434A-Z	D1322	Híbrida			•		8494-Z	D1386		•				
Q5	2013	2017	8891-Z	D1663	2.0, 3.0 L			•		8494-Z	D1386		•				
Q7	2007	2015	8366-Z	D1014	Quattro / 30 Aniv. Quattro			•		7908-AZ	D978		•				
BMW																	
325	1997	1997	7437-Z	D558		•				7286-Z	D396		•				
1 SERIES M	2011	2011	7799-Z	D918				•		7820-Z	D919		•				
125i	2008	2011	7967-Z	D1061				•		7286-Z3	D1267		•				
128i	2008	2013	7967-Z	D1061				•		7286-Z3	D1267		•				
135i	2008	2013	8483-Z	D1371				•		8484-Z	D1372		•				
135iS	2013	2013	8483-Z	D1371				•		8484-Z	D1372		•				
228i	2014	2016	8772-Z	D1561	Base, M sport, xDrive					8826-Z	D1613		•				
228i	2016	2016	8822-Z	D1880	Cáliper Azul			•									
230i	2017	2017	8772-Z	D1561				•		8826-Z	D1613		•				
230i	2017	2017	8772-Z	D1561	xDrive			•		8826-Z	D1613		•				
230i	2017	2017	8822-Z	D1880	Cáliper Azul			•									
230i	2017	2017	8822-Z	D1880	xDrive Cáliper Azul			•									
318i	1991	1992	7437-Z	D558		•											
318i	1992	1999	7437-Z	D558		•				7286-Z	D396		•				
318iC	1994	1997	7437-Z	D558		•											
318iS	1992	1999	7437-Z	D558		•				7286-Z	D396		•				
318Ti	1995	1998	7437-Z	D558		•				7286-Z	D396		•				
320i	2001	2005	7437-Z	D558		•				7286-Z	D396		•				
320i	2013	2016			Base, xDrive					8826-Z	D1613		•				
320i	2013	2017	8772-Z	D1561	Base, xDrive			•		8826-Z	D1613		•				
320i	2016	2017	8822-Z	D1880	Cáliper Azul			•									
320i	2016	2017	8822-Z	D1880	Cáliper Azul			•									
323Ci	2000	2000	7649-Z	D781				•									
323i	1998	2000	7649-Z	D781				•		7286-Z	D396		•				
323i	1998	2000	7847-Z	D781	Sport wagon			•									
323i	1999	1999	7649-Z	D781	Convertible			•		7286-Z	D396		•				
323i	2006	2007	7967-Z	D1061				•									
323i	2007	2011	7799-Z	D918				•									
323i	2010	2013	7799-Z1	D1260				•		7286-Z3	D1267		•				
323iS	1998	1999	7649-Z	D781				•									
325Ci	2001	2006	7847-Z	D781				•									
325Ci	2007	2007	7967-Z	D1061				•		7286-Z	D396		•				
325i	1992	1993	7437-Z	D558		•											
325i	1992	1999	7437-Z	D558		•				7286-Z	D396		•				
325i	2001	2006	7847-Z	D781				•									
325i	2006	2007	7967-Z	D1061				•									
325iS	1992	1995	7437-Z	D558		•				7286-Z	D396		•				
325Xi	2001	2005	7847-Z	D781				•									
325Xi	2006	2007	7967-Z	D1061				•		7286-Z	D396		•				
328d	2014	2017	8772-Z	D1561	Base, xDrive			•		8826-Z	D1613		•				
328i	1996	1997	7437-Z	D558		•				7286-Z	D396		•				
328i	1998	1999	7847-Z	D781				•									
328i	2007	2008	7967-Z	D1061				•		7286-Z3	D1267		•				
328i	2009	2013	7799-Z1	D1260				•		7286-Z3	D1267		•				
328i	2013	2016	8822-Z	D1880	Cáliper Azul			•									
328i	2012	2016	8822-Z	D1880	Base, M sport, xDrive			•		8826-Z	D1613		•				
328i	2014	2016	8772-Z	D1561	GT xDrive			•		8826-Z	D1613		•				
328i	2014	2016	8822-Z	D1880	Cáliper Azul			•									
328iC	1996	1997	8822-Z	D1880		•				7286-Z	D396		•				
328iS	1996	1997	7437-Z	D558		•				7286-Z	D396		•				
328Xi	2007	2007	7967-Z	D1061				•									
328Xi	2007	2008	7799-Z1	D1260				•		7286-Z3	D1267		•				
328Xi	2007	2013	7799-Z	D918				•		7286-Z3	D1267		•				
330Ci	2001	2006	7592-Z	D946				•		7427-Z2	D683		•				
330e	2016	2017	8772-Z	D1561				•		8826-Z	D1613		•				
330i	2001	2005	7592-Z	D946				•		7427-Z2	D683		•				

MODELO Model	AÑO Inicio	AÑO Final	BALATAS DELANTERAS			AZUL	FIX	SFC	SHD	BALATAS TRASERAS			AZUL	FIX	SFC	SHD	FT OW
			Pastilla	Zapata	Características					Pastilla	Zapata	Características					
330I	2006	2006	7967-Z	D1061				•	7427-Z1	D1170							
330I	2017	2017	8772-Z	D1561	Base, xDrive			•	8826-Z	D1613							
330I	2017	2017	8822-Z	D1880	M Sport			•	8823-Z	D1610							
330I	2017	2017	8822-Z	D1880	Cáliper Azul			•									
330XI	2001	2005	7592-Z	D946				•	7427-Z2	D683			•				•
330XI	2006	2006	7967-Z	D1061				•	7427-Z1	D1170							
335D	2009	2011	7799-Z	D918				•	7427-Z1	D1170							
335I	2007	2013	7799-Z	D918				•	7427-Z1	D1170							
335I	2012	2016	8822-Z	D1880	Base, GT xDrive, GT xDrive M Sport			•	8823-Z	D1610							
335IS	2011	2013	8822-Z	D1880				•	7427-Z1	D1170							
335XI	2007	2008	7967-Z	D1061				•	7427-Z1	D1170							
340I	2016	2017	8822-Z	D1880	Base, xDrive			•	8823-Z	D1610							
340I	2016	2017	8822-Z	D1880	Cáliper Azul. Base, xDrive			•									
428I	2014	2016	8772-Z	D1561	M Sport, xDrive, Base			•	8826-Z	D1613							
428I	2014	2016	8822-Z	D1880	Cáliper Azul			•									
430I	2017	2017	8822-Z	D1880	Base, xDrive, Gran Coupe			•	8826-Z	D1613							
430I	2017	2017	8822-Z	D1880	M Sport, Base, xDrive, Gran Coupe			•	8823-Z	D1610							
430I	2017	2017	8822-Z	D1880	Cáliper Azul			•									
435I	2014	2017	8822-Z	D1880	Base, M Sport, xDrive			•	8823-Z	D1610							
435I	2014	2017	8822-Z	D1880	Cáliper Azul			•									
440I	2017	2017	8822-Z	D1880	Base, xDrive, Gran Coupe			•	8823-Z	D1610							
440I	2017	2017	8822-Z	D1880	Cáliper Azul, Base, xDrive, Gran Coupe			•									
525I	1986	1995							7286-Z	D396			•				•
525I	2004	2009	7967-Z	D1061	Transmisión Manual			•	7427-Z	D1042							
525I	2004	2009	7799-Z	D918	Transmisión Automática			•	7427-Z	D1042							
525IT	1993	1995							7286-Z	D396			•				•
525XI	2006	2007	7799-Z	D918				•									
528I	2009	2010	7799-Z	D918	xDrive			•	7427-Z	D1042							
528I	2011	2016							8672-Z	D1473							
528XI	2008	2008	7799-Z	D918				•									
530I	1994	1995							7286-Z	D396			•				•
530I	2001	2003	7560-Z	D681				•	7286-Z	D396			•				•
530I	2004	2007							7427-Z	D1042			•				
530I	2018	2018							8672-Z	D1473			•				
530IT	1994	1995							7286-Z	D396			•				•
535I	1990	1993							7286-Z	D396			•				•
535I	2008	2010	7799-Z	D918				•	7820-Z	D919			•				
535I	2009	2010	7799-Z	D918	xDrive			•	7427-Z	D1042			•				
535I	2011	2016							8672-Z	D1473			•				
535IS	1988	1988							7286-Z	D396			•				•
535XI	2008	2008	7799-Z	D918				•									
540I	1994	1996							7286-Z	D396			•				•
540I	1996	2003	7560-Z	D681				•	7286-Z	D396			•				•
545I	2004	2006	7799-Z	D918				•	7820-Z	D919			•				
550I	2006	2010	7799-Z	D918				•	7820-Z	D919			•				
650I	2007	2010	7799-Z1	D1260				•	7820-Z	D919			•				
735I	1987	1992							7286-Z	D396			•				•
735IL	1988	1992							7286-Z	D396			•				•
740I	1993	1994							7286-Z	D396			•				•
740I	1995	2001	7560-Z	D681				•	7427-Z2	D683			•				•
740IL	1993	1994							7286-Z	D396			•				•
745I	2002	2005	7799-Z	D918				•	7820-Z	D919			•				
745LI	2002	2005	7799-Z	D918				•	7820-Z	D919			•				
750I	2006	2008	7799-Z	D918				•	7820-Z	D919			•				
750IL	1988	1994							7286-Z	D396			•				•
750LI	2006	2008	7799-Z	D918				•	7820-Z	D919			•				
760I	2004	2006	7799-Z	D918				•	7820-Z	D919			•				
I8	2015	2017							8672-Z	D1473			•				
M	2000	2002							7286-Z	D396			•				•
M3	1988	1999							7286-Z	D396			•				•
M3	2001	2004							7427-Z2	D683			•				•
M3	2003	2006	7592-Z	D946				•	7427-Z2	D683			•				•
M3	2008	2013	7799-Z	D918				•	7820-Z	D919			•				
M5	1991	1994							7286-Z	D396			•				•
M5	1999	2003	7560-Z	D681				•	7427-Z2	D683			•				•
SDRIVE 28i	2012	2016							8550-Z	D1433			•				
Z3	1996	1999	7437-Z	D558				•	7286-Z	D396			•				•
Z3	1998	2002							7286-Z	D396			•				•
Z4	2003	2008			3.0 Si				7286-Z	D396			•				•
Z4	2005	2008	7847-Z	D781				•									

MODELO Model	AÑO Inicio	AÑO Final	BALATAS DELANTERAS			AZUL	FIX	SPC	SHD	BALATAS TRASERAS			AZUL	FIX	SPC	SHD	FT OW
			Pastilla	Zapata	Características					Pastilla	Zapata	Características					
Z4	2006	2008	7592-Z	D946	3.0 Si, M					7427-Z2	D683						
Z4	2009	2011								8550-Z	D1433						
Z4	2009	2016	7967-Z	D1061	sDrive28i, sDrive35i												
Z4	2011	2016	7799-Z	D918	sDrive35is					8672-Z	D1473						
Z4 SDRIVE35i	2012	2016								8550-Z	D1433						
BMW TRUCK																	
X1	2012	2015	7799-Z1	D1260	xDrive35i					7427-Z1	D1170						
X1	2012	2015	7799-Z1	D1260	sDrive 28i, xDrive28i					7286-Z3	D1267						
X3	2004	2010	7592-Z	D946						7427-Z2	D683						
X3	2011	2017	8772-Z	D1561						8672-Z	D1473						
X4	2015	2017	8772-Z	D1561						8672-Z	D1473						
X4	2017	2017	8411-Z	D1294	M40i					8672-Z	D1473						
X5	2000	2006	7560-Z	D681						7427-Z2	D683						
X5	2002	2006								7427-Z2	D683						
X5	2007	2017	8411-Z	D1294	xDrive35i, xDrive35d, sDrive35i, 4.8i					7820-Z	D919						
X5	2007	2017	8411-Z	D1294	xDrive 35i, xDrive 35d, sDrive 35i, 3.0si					7427-Z	D1042						
X5	2011	2014			M, xDrive50i					7820-Z	D919						
X6	2008	2017	8411-Z	D1294	xDrive 35i, M, xDrive50i					7820-Z	D919						
X6	2008	2017	8411-Z	D1294	sDrive 35i					7427-Z	D1042						
BUICK																	
ALLURE	2005	2009	7980-Z	D1075													
ALLURE	2008	2008	8269-Z	D1159													
APOLLO	1973	1975	728-AZ	D52													
CENTURY	1973	1977	728-AZ	D52													
CENTURY	1978	1981	7070-Z	D154													
CENTURY	1982	1989	7070-CZ	D183						2165T	S552						
CENTURY	1984	1992	7136-Z	D215						2165T	S552						
CENTURY	1985	1989	7192-Z	D289						2165T	S552						
CENTURY	1990	1996	7136-Z	D215						1394	S636						
CENTURY	1997	1997	7574-Z	D699													
CENTURY	1997	2001	7693-Z	D699A						7387-Z2	D714						
CENTURY	2000	2005	7574-Z	D699						7387-Z2	D714						
ELECTRA	1972	1978	728-AZ	D52													
ELECTRA	1985	1986	7136-Z	D215						2165T	S552						
ELECTRA	1987	1990	7136-Z	D215						2134BT	S652						
ESTATE WAGON	1972	1979	728-AZ	D52													
LACROSSE	2005	2009	7980-Z	D1075													
LACROSSE	2008	2009	8269-Z	D1159						7387-Z3	D814						
LACROSSE	2010	2017	8536-Z	D1421						8547-Z	D1430						
LACROSSE	2017	2017	9114-Z	D1886	Rin 17												
LESABRE	1978	1978	728-AZ	D52													
LESABRE	1986	1990	7136-Z	D215													
LESABRE	1990	1990	728-AZ	D52						2134BT	S652						
LESABRE	1990	1990	728-Z	D52						2134BT	S652						
LESABRE	1990	1991	7136-Z	D215						2134BT	S652						
LESABRE	1992	1993	7384-Z	D505													
LESABRE	1994	1999	7384-Z1	D623													
LESABRE	2000	2005	7574-Z	D699						7387-Z2	D714						
LESABRE	2000	2005	7693-Z	D699A						7387-Z2	D714						
LUCERNE	2006	2011	8269-Z	D1159													
PARK AVENUE	1991	1993	7384-Z	D505													
PARK AVENUE	1994	1996	7384-Z1	D623													
PARK AVENUE	1997	2004	7693-Z	D699A						7387-Z2	D714						
RAINIER	2004	2005	7759-Z	D882						7760-Z	D883						
RAINIER	2006	2007	8282-Z	D1169						7760-Z	D883						
REGAL	1977	1977	728-AZ	D52													
REGAL	1978	1978	7070-Z	D154													
REGAL	1982	1987	7070-AZ1	D154													
REGAL	1988	1993	7265-Z	D376													
REGAL	1994	1996	7265-Z	D376						7387-Z2	D714						
REGAL	1997	2004	7693-Z	D699A						7387-Z2	D714						
REGAL	2012	2013	7902-Z	D1001	GS												
REGAL	2011	2017	8536-Z	D1421						8547-Z	D1430						
RIVIERA	1972	1978	728-AZ	D52													
RIVIERA	1979	1981	7070-Z	D154						7070-AZ1	D154						
RIVIERA	1982	1985	7070-AZ1	D154						2117ATT	S514						
RIVIERA	1992	1993	7384-Z	D505						7387-Z2	D714						
RIVIERA	1995	1996	7384-Z1	D623						7387-Z2	D714						

MODELO Model	AÑO Inicio	AÑO Final	BALATAS DELANTERAS			AZUL	FIX	SFC	SHD	BALATAS TRASERAS			AZUL	FIX	SFC	SHD	FT OW
			Pastilla	Zapata	Características					Pastilla	Zapata	Características					
RIVIERA	1997	1999	7693-Z	D699A		•	•		7387-Z2	D714		•	•				
SKYHAWK	1985	1989	7192-Z	D289		•	•		2164	S553						•	
SKYLARK	1976	1979	728-AZ	D52		•		•									
SKYLARK	1980	1984	7070-CZ	D183		•											
SKYLARK	1985	1990	7192-Z	D289		•	•		2164	S553						•	
SKYLARK	1990	1996	7385-Z	D506		•	•		2164	S553						•	
SKYLARK	1996	1998	7554-Z	D673		•	•		2164	S553						•	
SOMERSET	1985	1987	7192-Z	D289		•	•		2164	S553						•	
VERANO	2013	2017	8667-Z	D1467		•	•		8668-Z	D1468			•				
BUICK TRUCK																	
ENCLAVE	2008	2017	8410-Z	D1169		•	•		7760-Z	D883		•	•				
ENCORE	2013	2018	8667-Z	D1467		•	•		8668-Z	D1468			•				
ENVISION	2017	2018	9114-Z	D1886		•	•										
RENDEZVOUS	2002	2007	7720-Z	D844		•	•		7387-Z3	D814		•	•				
TERRAZA	2005	2007	7980-Z	D1075		•	•		7999-Z	D1093		•	•				
CADILLAC																	
60 SPECIAL	1993	1993	7259-Z1	D369		•	•		2134BTT	S652						•	
60 SPECIAL	1993	1993	7384-Z	D505		•	•		2134BTT	S652						•	
ALLANTE	1993	1993	7384-Z	D505		•	•		7387-Z2	D714		•	•				
ATS	2013	2015	8667-Z	D1467		•	•										
CATERA	1997	2001							7582-Z	D709		•					
CIMARRON	1985	1988	7192-Z	D289		•	•		2164	S553						•	
COMMERCIAL CHASSIS	1980	1984	728-AZ	D52		•		•									
CTS	2003	2007							8207-Z	D922			•				
CTS	2009	2014	8513-Z	D1405				•	7958-Z	D1053			•				
DEVILLE	1980	1984	728-AZ	D52		•		•									
DEVILLE	1985	1989	7136-Z	D215		•	•		2165T	S552						•	
DEVILLE	1990	1990	7136-Z	D215		•	•		2134BTT	S652						•	
DEVILLE	1990	1999	7259-Z1	D369		•	•		2134BTT	S652						•	
DEVILLE	1991	1993	7259-Z1	D369		•	•		1394	S636						•	
DEVILLE	1991	1993	7384-Z	D505		•	•		1394	S636						•	
DEVILLE	1991	1993	7384-Z	D505		•	•		2134BTT	S652						•	
DEVILLE	1994	1996	7384-Z1	D623		•	•		7387-Z	D508		•	•				
DEVILLE	1996	1996	7384-Z1	D623		•	•		7387-Z2	D714		•	•				
DEVILLE	1997	1997	7574-Z	D699		•	•		7387-Z2	D714		•	•				
DEVILLE	1997	1999	7693-Z	D699A		•	•		2134BTT	S652						•	
DEVILLE	1997	1999	7259-Z1	D369		•	•		7387-Z2	D714		•	•				
DEVILLE	1997	2005	7693-Z	D699A		•	•		7387-Z2	D714		•	•				
DEVILLE	2000	2005	7574-Z	D699		•	•		7387-Z2	D714		•	•				
DEVILLE	2000	2005	8454-Z	D784		•	•	•	7387-Z2	D714		•	•				
DEVILLE	2000	2005	7574-Z	D699		•	•		7700-Z	D792		•	•				
DEVILLE	2000	2005	7693-Z	D699A		•	•		7700-Z	D792		•	•				
DEVILLE	2000	2005	8454-Z	D784		•	•	•	7700-Z	D792		•	•				
DTS	2006	2006	7652-Z	D784		•	•	•	7700-Z	D792		•	•				
DTS	2006	2011	8269-Z	D1159		•	•		7700-Z	D792		•	•				
DTS	2007	2011	8454-Z	D784		•	•	•	7700-Z	D792		•	•				
EL DORADO	1980	1981	7070-Z	D154		•	•		7070-AZ1	D154		•	•				
EL DORADO	1980	1985	7070-AZ1	D154		•	•	•	2117ATT	S514						•	
EL DORADO	1992	1993	7384-Z	D505		•	•		7387-Z	D508		•	•				
EL DORADO	1994	1996	7384-Z1	D623		•	•		7387-Z	D508		•	•				
EL DORADO	1997	2002	7574-Z	D699		•	•		7387-Z2	D714		•	•				
EL DORADO	1998	1999	7693-Z	D699A		•	•		7387-Z	D508		•	•				
EL DORADO	2000	2002	7693-Z	D699A		•	•		7387-Z2	D714		•	•				
FLEETWOOD	1980	1984	728-AZ	D52		•		•									
FLEETWOOD	1985	1986	728-AZ	D52		•	•		2134BTT	S652						•	
FLEETWOOD	1985	1986	7136-Z	D215		•	•		2165T	S552						•	
FLEETWOOD	1985	1986	728-AZ	D52		•		•	2165T	S552						•	
FLEETWOOD	1985	1990	7136-Z	D215		•	•		2134BTT	S652						•	
FLEETWOOD	1990	1992	7259-Z1	D369		•	•		2134BTT	S652						•	
FLEETWOOD	1991	1992	7384-Z	D505		•	•		2134BTT	S652						•	
SEVILLE	1980	1981	7070-Z	D154		•	•		7070-AZ1	D154		•	•				
SEVILLE	1980	1985	7070-AZ1	D154		•	•	•	2117ATT	S514						•	
SEVILLE	1992	1993	7384-Z	D505		•	•		7387-Z	D508		•	•				
SEVILLE	1994	1996	7384-Z1	D623		•	•		7387-Z	D508		•	•				
SEVILLE	1997	2004	7574-Z	D699		•	•		7387-Z2	D714		•	•				
SEVILLE	2003	2004	7693-Z	D699A		•	•		7387-Z2	D714		•	•				
STS	2005	2009							7958-Z	D1053							
STS	2005	2011							8207-Z	D922			•				

MODELO Model	AÑO Inicio	AÑO Final	BALATAS DELANTERAS							BALATAS TRASERAS						
			Pastilla	Zapata	Características	AZUL	FIX	SPC	SHD	Pastilla	Zapata	Características	AZUL	FIX	SPC	SHD
CADILLAC TRUCK																
ESCALADE	1999	2000	7259-Z1	D369												
ESCALADE	2002	2006	7653-Z	D785					7707-Z	D834						
ESCALADE	2002	2006	7653-Z	D785					7881-Z	D974						
ESCALADE	2007	2007	7997-Z	D1092					8312-Z	D1194						
ESCALADE	2008	2018	8472-Z	D1363					8312-Z	D1194						
CHEVROLET																
ASTRA	2000	2003	766X-Z	F186	1.8L				1516	S751						
ASTRA	2000	2003	766X-AZ	F186	1.8L/2.2L / Vagoneta (Sin ABS)				8661-Z	D1461						
ASTRA	2000	2003	766X-AZ	F186	2.0L (Sin ABS)				8661-Z	D1461						
ASTRA	2000	2003	8725-Z	D1516	1.8L/2.2L / Vagoneta (Con ABS)				778X-Z	F202						
ASTRA	2004	2006	8725-Z	D1516	2.0L				1516	S751						
ASTRA	2004	2006	766X-AZ	F186	2.4L Sin ABS				7614-Z	D709						
ASTRA	2004	2006	768X-AZ	F185	2.0L / 2.4L (Con ABS)				778X-Z	F202						
ASTRA	2004	2006	8725-Z	D1516	2.4L Con ABS				778X-Z	F202						
ASTRA	2007	2008	8725-Z	D1516	2.0T / 1.8 Con ABS				7614-Z	D709						
ASTRA	2007	2008	8725-Z	D1516	2.0T / 1.8 Sin ABS				8661-Z	D1461						
ASTRA	2008	2008	8470-Z	D1361	1.8L Sedan				778X-Z	F202						
AVEO	2004	2017	7779-Z1	D1035					1547	S814						
AVEO	2018	2019	9167-Z	D1942												
BEAT	2018	2018	8801-Z	D1590	LS,LT,LTZ				1547	S814						
BERETTA	1987	1991	7192-Z	D289					2164	S553						
BERETTA	1992	1995	7385-Z	D506					2164	S553						
BERETTA	1996	1996	7554-Z	D673					2164	S553						
CAMARO	1971	1981	728-AZ	D52												
CAMARO	1982	1992	7070-AZ1	D154					2117ATT	S514						
CAMARO	1988	1992	7300-Z	D412					2117ATT	S514						
CAMARO	1988	1992	7070-AZ1	D154												
CAMARO	1988	1992	7300-Z	D412												
CAMARO	1993	1993	7384-Z	D505					2117ATT	S514						
CAMARO	1993	1993	7384-Z	D505												
CAMARO	1994	1997	7384-Z1	D623					2117ATT	S514						
CAMARO	1994	1997	7384-Z1	D623												
CAMARO	1998	2002	7618-Z	D749					7619-Z	D750						
CAMARO	2010	2014	8512-Z	D1404	Motor V6				7958-Z	D1053						
CAMARO	2012	2015	8513-Z	D1405	Motor V8, ZL1				7958-Z	D1053						
CAMARO	2015	2015	8512-Z	D1404	LS				8238-Z	D1129						
CAMARO	2016	2017	9114-Z	D1886												
CAPRICE	1977	1981	728-AZ	D52												
CAPRICE	1981	1981	728-Z	D52												
CAPRICE	1993	1993							2134BT	S652						
CAVALIER	1985	1991	7192-Z	D289					2164	S553						
CAVALIER	1992	2002	7385-Z	D506					2164	S553						
CAVALIER	2000	2002	7554-Z	D673					2164	S553						
CAVALIER	2003	2004	7385-Z	D506					1535	S795						
CAVALIER	2003	2004	7554-Z	D673					1535	S795						
CELEBRITY	1982	1984	7070-CZ	D183					2165T	S552						
CELEBRITY	1982	1990	7136-Z	D215					2165T	S552						
CELEBRITY	1985	1989	7192-Z	D289					2165T	S552						
CHEVELLE	1970	1973	728-AZ	D52												
CHEVETTE	1985	1987							2164	S553						
CHEVY	1994	2003	8983-Z	D1755					1665	S994						
CHEVY	1994	2012	7563-Z	D688					1665	S994						
CHEVY	2000	2002	8284-Z	D1173	Wagon, Pick Up				1665	S994						
CITATION	1980	1988	7070-CZ	D183					2164	S553						
CORSA	2002	2008	8290-Z	D1176					1665	S994						
CORVETTE	1988	1996	7300-Z	D412												
CORVETTE	2012	2017	8238-Z	D1129	Z06, J57				8238-Z	D1129						
CRUZE	2010	2016	84X0-Z	F368					1663	S992						
CRUZE	2010	2016	84X0-Z	F368	LTZ				8668-Z	D1468						
CUTLASS	1972	1977	728-AZ	D52												
CUTLASS	1978	1981	7070-Z	D154												
CUTLASS	1985	1987	7070-AZ1	D154					2117ATT	S514						
CUTLASS	1988	1989	7136-Z	D215					2165T	S552						
CUTLASS	1990	1990	7136-Z	D215												
CUTLASS	1990	1990	7265-Z	D376												
CUTLASS	1991	1996	7136-Z	D215					1394	S636						
CUTLASS	1997	1997	7594-Z	D727					1496	S720						

MODELO Model	AÑO Inicio	AÑO Final	BALATAS DELANTERAS			AZUL	FIX	SFC	SHD	BALATAS TRASERAS			AZUL	FIX	SFC	SHD	FT OW
			Pastilla	Zapata	Características					Pastilla	Zapata	Características					
CUTLASS	1997	1999	7735-Z	D752		•	•		1496	S720							•
EUROSPORT	1991	1996	7136-Z	D215		•	•										•
F650	2001	2002	7636-Z1	D1032				•									•
IMPALA	1972	1978	728-AZ	D52		•		•									•
IMPALA	1985	1985	728-AZ	D52		•		•	2134BT	S652							•
IMPALA	1994	1996							2134BT	S652							•
IMPALA	2000	2005	7574-Z	D699		•	•		7387-Z2	D714		•		•			•
IMPALA	2000	2005	7693-Z	D699A		•	•		7387-Z2	D714		•		•			•
IMPALA	2000	2005	7574-Z	D699		•	•		7387-Z3	D814		•		•			•
IMPALA	2000	2005	7693-Z	D699A		•	•		7387-Z3	D814		•		•			•
IMPALA	2006	2010	8269-Z	D1159				•	7387-Z3	D814		•		•			•
IMPALA	2011	2013	8269-Z	D1159				•									•
IMPALA	2014	2015	8536-Z	D1421				•									•
MALIBU	1978	1981	7070-Z	D154		•			2117ATT	S514							•
MALIBU	1980	1983	7070-AZ1	D154		•	•	•	2117ATT	S514							•
MALIBU	1997	2003	7735-Z	D752		•	•		1496	S720							•
MALIBU	2000	2003	7594-Z	D727		•	•		1496	S720							•
MALIBU	2004	2006	7932-Z	D1028		•	•		7937-Z	D1033		•		•			•
MALIBU	2004	2010	8270-Z	D1160		•	•		7937-Z	D1033		•		•			•
MALIBU	2011	2012	7932-Z	D1028		•	•		7937-Z	D1033		•		•			•
MALIBU	2013	2017	8536-Z	D1421					8547-Z	D1430			•				•
MATIZ	2004	2015	8433-Z	D1321		•	•	•	1666	S995							•
METRO	1989	1989	7153-Z	D242		•											•
METRO	1990	1990	7310-Z	D420		•											•
METRO	1995	1996	7331-Z	D451		•			1461	S630							•
MONTE CARLO	1970	1977	728-AZ	D52		•		•									•
MONTE CARLO	1978	1982	7070-Z	D154		•											•
MONTE CARLO	1982	1988	7070-AZ1	D154		•	•	•	2117ATT	S514							•
MONTE CARLO	1995	1999	7265-Z	D376		•	•		7387-Z2	D714		•		•			•
MONTE CARLO	2000	2005	7574-Z	D699		•	•		7387-Z2	D714		•		•			•
MONTE CARLO	2001	2004	7693-Z	D699A		•	•		7387-Z2	D714		•		•			•
MONTE CARLO	2006	2007	8269-Z	D1159				•	7387-Z2	D714		•		•			•
MONTE CARLO	2006	2007	8269-Z	D1159				•	7387-Z3	D814		•		•			•
NOVA	1972	1979	728-AZ	D52		•		•									•
NOVA	1985	1988	7153-Z	D242		•											•
OPTRA	2004	2010	7779-Z1	D1035		•	•		7939-Z	D1036	Balata de 104.4 mm de largo	•		•			•
OPTRA	2006	2010	7779-Z1	D1035		•	•		7939-Z1	D1315	Balata de 103.9 mm de largo	•		•			•
PRIZM	1989	1992	7153-Z	D242		•											•
PRIZM	1993	1997	7441-Z	D562		•	•										•
PRIZM	1998	2002	7611-Z	D741		•	•										•
SONIC	2011	2017	8926-Z	D1702		•	•		1480	S814							•
SONIC	2012	2017	8X30-Z	F391		•	•		1480	S814							•
SONIC	2014	2015	84X0-Z	F368	Versión RS	•	•		8668-Z	D1468			•				•
SPARK	2011	2017	8801-Z	D1590	Classic	•	•		1547	S814							•
SPARK NG	2016	2018	9093-Z	D1864	LT y Hot	•	•		1547	S814							•
SPARK NG	2016	2018	9254-Z	D2024	LIZ	•	•		1547	S814							•
SPRINT	1972	1977	728-AZ	D52		•		•									•
SPRINT	1977	1979	7735-Z	D752		•	•										•
SPRINT	1985	1992	7310-Z	D420		•											•
SPRINT	1990	1992	7331-Z	D451		•											•
SSR	2003	2006	7759-Z	D882		•	•		7760-Z	D883		•		•			•
TIGRA	1999	1999	7563-Z	D688		•	•		7563-Z	D688		•		•			•
VECTRA	2003	2005	7873-Z	D972	2.2L	•	•		7874-Z	D973		•		•			•
VECTRA	2003	2006	7Y10A-Z	F232	Con Sensor de Desgaste	•	•		7874-Z	D973		•		•			•
VECTRA	2003	2006	7Y10-Z	F232	Sin Sensor de Desgaste	•	•		7874-Z	D973		•		•			•
VECTRA	2007	2007	7Y06-Z	F219		•	•		7874-Z	D973		•		•			•
CHEVROLET TRUCK																	
400SS PICKUP	1992	1997	7259-Z1	D369		•	•		1404A	S675							•
ASTRO	1990	2002	7259-Z1	D369		•	•		2117ATT	S514							•
ASTRO	2000	2002	728-AZ	D52				•	2117ATT	S514							•
ASTRO	2000	2002	728-Z	D52					2117ATT	S514							•
ASTRO	2003	2005	7653-Z	D785		•	•	•	7700-Z	D792		•		•			•
AVALANCHE	2007	2007	7997-Z	D1092		•	•	•	8312-Z	D1194		•		•			•
AVALANCHE	2008	2013	8472-Z	D1363		•	•	•	8312-Z	D1194		•		•			•
AVALANCHE 1500	2002	2006	7653-Z	D785		•	•	•	7707-Z	D834		•		•			•
AVALANCHE 1500	2002	2006	7653-Z	D785		•	•	•	7881-Z	D974		•		•			•
AVALANCHE 2500	2002	2006	7652-Z	D784		•	•	•	7653-Z	D785		•		•			•
BLAZER	1990	1991	728-AZ	D52		•	•		2073T	S473							•
BLAZER	1990	1991	728-Z	D52		•	•		2073T	S473							•

MODELO Model	AÑO Inicio	AÑO Final	BALATAS DELANTERAS							BALATAS TRASERAS							FT OW			
			Pastilla	Zapata	Características	AZUL	FIX	SPC	SHD	Pastilla	Zapata	Características	AZUL	FIX	SPC	SHD				
BLAZER	1992	1994	7259-Z1	D369					1404A	S675										
BLAZER	1995	1997	7070-AZ1	D154					2117ATT	S514										
BLAZER	1996	1997	7634-Z	D767					2117ATT	S514										
BLAZER	1997	1997	7593-Z	D726					2117ATT	S514										
BLAZER	1997	1997	7070-AZ1	D154					7596-Z	D729										
BLAZER	1997	1997	7634-Z	D767					7596-Z	D729										
BLAZER	1997	2005	7593-Z	D726					7596-Z	D729										
C6H024	1995	1998	7636-Z1	D1032																
C7H024	1995	1998	7636-Z1	D1032																
C4500 KODIAK	2009	2009	7636-Z1	D1032																
C5	2002	2002	7636-Z1	D1032																
C5500 KODIAK	2009	2009	7636-Z1	D1032																
C6	2002	2002	7636-Z1	D1032																
C6500 KODIAK	2009	2009	7636-Z1	D1032																
C7	2002	2002	7636-Z1	D1032																
C7500 KODIAK	2009	2009	7636-Z1	D1032																
C10	1971	1971							2006	S280										
C10	1972	1975	728-AZ	D52					2006	S280										
C10	1976	1977	728-Z	D52																
C10	1979	1979	728-AZ	D52					2073T	S473										
C10	1979	1979	728-Z	D52					2073T	S473										
C10	1980	1987	728-AZ	D52					2073T	S473										
C10	1980	1987	728-Z	D52					2073T	S473										
C1500	1988	1991	7259-Z	D368					1404A	S675										
C1500	1988	1999	7259-Z1	D369					1404A	S675										
C1500	1997	1997	7260A-Z	D370MA					1404A	S675										
C1500	1997	1997	7260-Z	D370					1404A	S675										
C1500	2000	2000	7259-Z1	D369					2073T	S473										
C20	1972	1972	728-AZ	D52																
C20	1973	1974	728-AZ	D52					2006	S280										
C20	1975	1977	728-AZ	D52																
C20	1985	1987	7084-Z	D153					2042AT	S451										
C20	1985	1987	728-AZ	D52					2042AT	S451										
C20	1985	1987	728-Z	D52					2042AT	S451										
C25	1979	1979	728-AZ	D52					2042AT	S451										
C2500	1979	1979	7084-Z	D153					2042AT	S451										
C2500	1979	1979	7084-Z	D153					2073T	S473										
C2500	1987	1991	7259-Z1	D369					2042AT	S451										
C2500	1987	1998	7259-Z1	D369					2073T	S473										
C2500	1988	1991	7260-Z	D370					2042AT	S451										
C2500	1990	1991	7260A-Z	D370MA					2042AT	S451										
C2500	1998	1998	7260A-Z	D370MA					2042AT	S451										
C2500	1998	1998	7260-Z	D370					2042AT	S451										
C2500	1998	1998	7260A-Z	D370MA					2073T	S473										
C2500	1998	1998	7260-Z	D370					2073T	S473										
C2500	1998	2000	7259-Z1	D369					2042AT	S451										
C2500	2000	2000	7260A-Z	D370MA					2042AT	S451										
C2500	2000	2000	7260-Z	D370					2042AT	S451										
C2500	2000	2000	7259-Z1	D369					2073T	S473										
C2500	2000	2000	7260A-Z	D370MA					2073T	S473										
C2500	2000	2000	7260-Z	D370					2073T	S473										
C30	1972	1976	728-AZ	D52																
C30	1976	1976	7081-Z	D149					2157T	S452										
C30	1976	1978	728-AZ	D52					2157T	S452										
C30	1977	1978	728-AZ	D52					2042AT	S451										
C30	1980	1987	7081-Z	D149					2042AT	S451										
C30	1980	1987	7084-Z	D153					2042AT	S451										
C30	1980	1987	7084-Z	D153					2157T	S452										
C30	1987	1987	7081-Z	D149					2157T	S452										
C30	1991	1991	7339-Z	D459					2157T	S452										
C3500	1988	1994	7260-Z	D370					2042AT	S451										
C3500	1990	1994	7339A-Z	D459MA					2042AT	S451										
C3500	1990	1994	7339-Z	D459					2042AT	S451										
C3500	1991	1991	7339A-Z	D459MA					2157T	S452										
C3500	1991	1991	7339A-Z	D459MA					7081-Z	D149										
C3500	1991	1993	7260-Z	D370					7081-Z	D149										
C3500	1991	1993	7339-Z	D459					7081-Z	D149										
C3500	1991	1994	7081-Z	D149					7081-Z	D149										
C3500	1992	1996	7260-Z	D370																
C3500	1992	1996	7339-Z	D459																

MODELO Model	AÑO Inicio	AÑO Final	BALATAS DELANTERAS			AZUL	FIX	SFC	SHD	BALATAS TRASERAS			AZUL	FIX	SFC	SHD	FT OW
			Pastilla	Zapata	Características					Pastilla	Zapata	Características					
C3500	1994	1994	7815-Z	D380		•		•	7081-Z	D149		•					
C3500	1994	2002	7815-Z	D380		•		•	7815-Z	D380		•					
C3500	2000	2000	7260-Z	D370		•		•	2157T	S452						•	
C3500	2000	2000	7339A-Z	D459MA		•		•	2157T	S452						•	
C3500	2000	2000	7339-Z	D459		•		•	2157T	S452						•	
C3500	2000	2000	7815-Z	D380		•		•	2157T	S452						•	
C3500	2011	2011	8523-Z	D1411				•	8523-Z	D1411			•			•	
CAPTIVA	2009	2011	7980-Z	D1075		•	•		8391-Z	D1275		•	•				
CAPTIVA SPORT	2012	2015	8381-Z	D1264		•	•		8391-Z	D1275		•	•				
CHEVY	1999	2005	8284-Z	D1173	Pickup	•	•		2X64	FT001						•	
CHEYENNE	2010	2010	8472-Z	D1363		•	•	•	8312-Z	D1194		•	•	•			
CHEYENNE	2011	2011	8523-Z	D1411				•	8523-Z	D1411			•				
COLORADO	2004	2008	7943-Z	D1039		•		•	1548	S815						•	
COLORADO	2009	2012	8282-Z	D1169		•		•	1643	S959						•	
COLORADO	2013	2015	8906-Z	D1677		•		•	1685	S1016						•	
COLORADO	2016	2018	9034-Z	D1802				•	9041-Z	D1806			•				
EL CAMINO	1983	1987	7070-AZ1	D154		•	•	•	2117ATT	S514						•	
EQUINOX	2005	2006	7794-Z1	D913		•	•	•	1500	S780						•	
EQUINOX	2007	2009	8381-Z	D1264		•	•		8391-Z	D1275		•	•				
EQUINOX	2010	2015	8536-Z	D1421				•	8391-Z	D1275		•	•				
EQUINOX	2016	2017	8512-Z	D1404		•	•	•	8391-Z	D1275		•	•				
EQUINOX	2018	2018	9114-Z	D1886				•									
EXPRESS 1500	1996	2002	7259-Z1	D369		•	•		2073T	S473						•	
EXPRESS 1500	2003	2008	7653-Z	D785		•	•	•	7891-Z	D989		•	•				
EXPRESS 1500	2003	2013	7653-Z	D785		•	•	•	7881-Z	D974		•	•				
EXPRESS 1500	2009	2014	8472-Z	D1363		•	•	•	7881-Z	D974		•	•				
EXPRESS 2500	1996	1999	7260A-Z	D370MA		•		•	2157T	S452						•	
EXPRESS 2500	1996	2002	7259-Z1	D369		•	•		2073T	S473						•	
EXPRESS 2500	1996	2002	7260-Z	D370		•		•	2157T	S452						•	
EXPRESS 2500	2000	2002	7339-Z	D459		•		•	2157T	S452						•	
EXPRESS 2500	2003	2004	7653-Z	D785		•	•	•	7875-Z	D974		•	•				
EXPRESS 2500	2003	2007	7652-Z	D784		•	•	•	7875-Z	D974		•	•				
EXPRESS 2500	2008	2017	8454-Z	D784		•	•	•	7875-Z	D974		•	•				
EXPRESS 3500	1996	1999	7260A-Z	D370MA		•		•	2157T	S452						•	
EXPRESS 3500	2000	2002	7260-Z	D370		•		•	2157T	S452						•	
EXPRESS 3500	2000	2002	7339A-Z	D459MA		•		•	2157T	S452						•	
EXPRESS 3500	2000	2002	7339-Z	D459		•		•	2157T	S452						•	
EXPRESS 3500	2003	2006	7652-Z	D784		•	•	•	7891-Z	D989		•	•				
EXPRESS 3500	2003	2014	8454-Z	D784		•	•	•	7875-Z	D974		•	•				
EXPRESS 3500	2007	2013	8454-Z	D784		•		•	7891-Z	D989		•	•				
EXPRESS 3500	2008	2015	8454-Z	D784		•	•	•	8523-Z	D1411						•	
EXPRESS 4500	2009	2013	8454-Z	D784		•		•	8523-Z	D1411			•				
G10	1980	1984	728-AZ	D52		•		•	2073T	S473						•	
G10	1980	1984	728-AZ	D52		•		•	2159TT	S449						•	
G10	1992	1993	728-AZ	D52		•		•									
G10	1992	1993	728-Z	D52		•											
G20	1980	1984	728-AZ	D52		•		•	2073T	S473						•	
G20	1992	1993	728-AZ	D52		•		•									
G20	1992	1993	728-Z	D52		•											
G30	1980	1984	728-AZ	D52		•		•	2042AT	S451						•	
G30	1980	1984	728-AZ	D52		•		•	2073T	S473						•	
G30	1980	1984	728-AZ	D52		•		•	2157T	S452						•	
HHR	2006	2009	8270-Z	D1160		•	•		1535	S795						•	
HHR	2008	2010	8489-Z	D1379	SS			•	7937-Z	D1033		•	•				
HHR	2009	2011	8270-Z	D1160		•	•		1540	S800						•	
K10	1980	1986	728-AZ	D52		•		•	2073T	S473						•	
K10	1985	1986	728-AZ	D52		•		•	2159TT	S449						•	
K1500	1988	1989	7259-Z	D368		•	•		1404A	S675						•	
K1500	1988	1991	7259-Z	D368		•	•		2073T	S473						•	
K1500	1992	2000	7259-Z1	D369		•		•	1404A	S675						•	
K20	1980	1984	728-AZ	D52		•		•	2042AT	S451						•	
K20	1980	1984	728-AZ	D52		•		•	2073T	S473						•	
K25	1980	1984	728-AZ	D52		•		•	2042AT	S451						•	
K2500	1980	1984	728-AZ	D52		•		•	2042AT	S451						•	
K2500	1988	1991	7259-Z1	D369		•	•		2042AT	S451						•	
K2500	1988	2000	7260-Z	D370		•		•	2042AT	S451						•	
K2500	1988	1997	7259-Z1	D369		•	•										
K2500	1990	1991	7260A-Z	D370MA		•		•	2042AT	S451						•	
K2500	1990	1995	7260A-Z	D370MA		•		•									
K3500	1988	1991	7260-Z	D370		•		•	2042AT	S451						•	

MODELO Model	AÑO Inicio	AÑO Final	BALATAS DELANTERAS							BALATAS TRASERAS							FT OW			
			Pastilla	Zapata	Características	AZUL	FIX	SPC	SHD	Pastilla	Zapata	Características	AZUL	FIX	SPC	SHD				
K3500	1988	2000	7260-Z	D370		•														
K3500	1990	1991	7339A-Z	D459MA		•				2042AT	S451									•
K3500	1990	1991	7339-Z	D459		•				2042AT	S451									•
K3500	1990	2000	7339-Z	D459		•														•
K3500	2000	2000	7260-Z	D370		•				2157T	S452									•
K3500	2000	2000	7339A-Z	D459MA		•				2157T	S452									•
K3500	2000	2000	7339-Z	D459		•				2157T	S452									•
K3500	2000	2000	7260A-Z	D370MA		•														•
K5 BLAZER	1980	1984	728-AZ	D52		•				2073T	S473									•
LUMINA	1990	1991	7136-Z	D215		•				2165T	S552									•
LUMINA	1990	1994	7265-Z	D376		•														•
LUMINA	1992	1993	7384-Z	D505		•														•
LUMINA	1994	1996	7384-Z1	D623		•														•
LUMINA	1995	2001	7265-Z	D376		•				7387-Z3	D814	•								•
LUMINA	1997	1997	7265-Z	D376		•				1394	S636									•
LUMINA	1997	1997	7265-Z	D376		•				7387-Z	D508	•								•
LUV	1997	2006	7347-Z	D363		•				1360	S619									•
MERIVA	2003	2008	8308	D1189		•				1516	S751									•
MERIVA	2007	2008	768X-AZ	F185	Imp. Alemana, Caliper ATE	•				778X-Z	F202	•								•
MICROBUS	1986	1987	728-AZ	D52		•				2157T	S452									•
MICROBUS	1986	1987	728-Z	D52		•				2157T	S452									•
MICROBUS	1986	1990	728-AZ	D52		•				2042AT	S451									•
MICROBUS	1986	1990	728-Z	D52		•				2042AT	S451									•
MICROBUS	1988	1989	7019-Z	D86		•				2171T	S583									•
MICROBUS	1990	1997	7179-AZ	D269		•				2171T	S583									•
MICROBUS	1991	1996	7081-Z	D149		•				2157T	S452									•
P10	1980	1980	728-AZ	D52		•				2073T	S473									•
P20	1980	1984	728-AZ	D52		•				2042AT	S451									•
P20	1980	1984	728-AZ	D52		•				2073T	S473									•
P30	1985	1991	7081-Z	D149		•				2042AT	S451									•
P30	1985	1991	7081-Z	D149		•				2157T	S452									•
P30	1985	1996	7081-Z	D149		•				7081-Z	D149	•								•
P30 VAN	1989	1999	7081-Z	D149		•				2042AT	S451									•
P30 VAN	2000	2002	7081-Z	D149		•														•
S10	1982	2002	7070-AZ1	D154		•				2117ATT	S514									•
S10	1991	1996	7480-Z	D202		•				2117ATT	S514									•
S10	1997	1997	7634-Z	D767	RWD	•				2117ATT	S514									•
S10	1998	1999	7593-Z	D726		•				7596-Z	D729	•								•
S10	1998	2002	7070-Z	D154	4X4	•				2117ATT	S514									•
S10	1998	2002	7070-AZ1	D154		•				7596-Z	D729	•								•
S10	1998	2003	7593-Z	D726	4X4	•				7596-Z	D729	•								•
S10	2003	2003	7593-Z	D726	RWD	•				2117ATT	S514									•
S10	2016	2018	8906-Z	D1677		•														•
SILVERADO	1994	1997	7260-Z	D370		•				2042AT	S451									•
SILVERADO	1995	1995	7260-Z	D370		•				1404A	S675									•
SILVERADO	1995	1995	7259-Z1	D369		•				2042AT	S451									•
SILVERADO	1995	1996	7259-Z1	D369		•				1404A	S675									•
SILVERADO	1997	1997	7339-Z	D459		•				2042AT	S451									•
SILVERADO	1997	1997	7260-Z	D370		•				2157T	S452									•
SILVERADO	1997	1997	7339-Z	D459		•				2157T	S452									•
SILVERADO	2006	2007	8282-Z	D1169		•				7760-Z	D883	•								•
SILVERADO 1500	1999	1999	7653-Z	D785		•				7662-Z	D792	•								•
SILVERADO 1500	1999	2001	7653-Z	D785		•				7653-Z	D785	•								•
SILVERADO 1500	2001	2006	7653-Z	D785		•				7700-Z	D792	•								•
SILVERADO 1500	2005	2006	7997-Z	D1092		•				7700-Z	D792	•								•
SILVERADO 1500	2005	2006	7997-Z	D1092		•				7707-Z	D834	•								•
SILVERADO 1500	2005	2007	7997-Z	D1092		•				1583	S855	•								•
SILVERADO 1500	2007	2007	7997-Z	D1092		•				8312-Z	D1194	•								•
SILVERADO 1500	2008	2008	8472-Z	D1363		•				1583	S855	•								•
SILVERADO 1500	2008	2018	8472-Z	D1363		•				8312-Z	D1194	•								•
SILVERADO 1500	2009	2013	8472-Z	D1363		•				1644	S960	•								•
SILVERADO 1500HD	2001	2007	7652-Z	D784		•				7653-Z	D785	•								•
SILVERADO 2500	1999	2010	7652-Z	D784		•				7653-Z	D785	•								•
SILVERADO 2500	2001	2004	7653-Z	D785		•				7788-Z	D909	•								•
SILVERADO 2500	2004	2004	7653-Z	D785		•				7653-Z	D785	•								•
SILVERADO 2500	2005	2006	7652-Z	D784		•				7788-Z	D909	•								•
SILVERADO 2500	2005	2006	7997-Z	D1092		•				7788-Z	D909	•								•
SILVERADO 2500	2007	2018	8472-Z	D1363	Doble cabina	•				8312-Z	D1194	•								•
SILVERADO 2500 HD	2001	2010	7652-Z	D784		•				7653-Z	D785	•								•
SILVERADO 2500 HD	2011	2015	8523-Z	D1411		•				8523-Z	D1411	•								•

MODELO Model	AÑO Inicio	AÑO Final	BALATAS DELANTERAS			AZUL	FIX	SFC	SHD	BALATAS TRASERAS			AZUL	FIX	SFC	SHD	FT OW
			Pastilla	Zapata	Características					Pastilla	Zapata	Características					
SILVERADO 3500	2001	2007	7652-Z	D784		.	.	.	7653-Z	D785		
SILVERADO 3500	2001	2007	7652-Z	D784		.	.	.	7788-Z	D909		
SILVERADO 3500	2007	2007	8454-Z	D784		.	.	.	7788-Z	D909		
SILVERADO 3500 HD	2007	2010	8454-Z	D784		.	.	.	7653-Z	D785		
SILVERADO 3500 HD	2007	2010	7652-Z	D784		.	.	.	7788-Z	D909		
SILVERADO 3500 HD	2011	2017	8523-Z	D1411		.	.	.	8523-Z	D1411		
SONORA	2000	2000	7652-Z	D784		.	.	.	7707-Z	D834		
SONORA	2001	2004	7653-Z	D785		.	.	.	7707-Z	D834		
SONORA	2005	2006	7653-Z	D785		.	.	.	7881-Z	D974		
SUBURBAN	1976	1984	728-AZ	D52		.	.	.	2042AT	S451		
SUBURBAN	1978	1984	728-AZ	D52		.	.	.	2073T	S473		
SUBURBAN 1500	1980	1984	728-AZ	D52		.	.	.	2073T	S473		
SUBURBAN 1500	1990	1991	728-AZ	D52		.	.	.	2042AT	S451		
SUBURBAN 1500	1990	1991	728-Z	D52		.	.	.	2042AT	S451		
SUBURBAN 1500	1990	1991	728-AZ	D52		.	.	.	2073T	S473		
SUBURBAN 1500	1990	1991	728-Z	D52		.	.	.	2073T	S473		
SUBURBAN 1500	1992	1999	7259-Z1	D369		.	.	.	2073T	S473		
SUBURBAN 1500	1995	1999	7260A-Z	D370MA		.	.	.	2042AT	S451		
SUBURBAN 1500	1995	1999	7260-Z	D370		.	.	.	2073T	S473		
SUBURBAN 1500	2000	2000	7653-Z	D785		.	.	.	7700-Z	D792		
SUBURBAN 1500	2000	2006	7653-Z	D785		.	.	.	7707-Z	D834		
SUBURBAN 1500	2002	2006	7653-Z	D785		.	.	.	7881-Z	D974		
SUBURBAN 1500	2007	2007	7997-Z	D1092		.	.	.	8312-Z	D1194		
SUBURBAN 1500	2008	2018	8472-Z	D1363		.	.	.	8312-Z	D1194		
SUBURBAN 2500	1980	1984	728-AZ	D52		.	.	.	2042AT	S451		
SUBURBAN 2500	1980	1991	728-AZ	D52		.	.	.	2073T	S473		
SUBURBAN 2500	1991	1991	728-Z	D52		.	.	.	2042AT	S451		
SUBURBAN 2500	1992	1999	7260-Z	D370		.	.	.	2073T	S473		
SUBURBAN 2500	2000	2007	7652-Z	D784		.	.	.	7653-Z	D785		
SUBURBAN 2500	2008	2013	8454-Z	D784		.	.	.	7653-Z	D785		
TAHOE	1995	2000	7259-Z1	D369		.	.	.	1404A	S675		
TAHOE	1997	2000	7260A-Z	D370MA		.	.	.	1404A	S675		
TAHOE	1997	2000	7260-Z	D370		.	.	.	1404A	S675		
TAHOE	1999	1999	7260A-Z	D370MA		.	.	.	2073T	S473		
TAHOE	1999	2000	7259-Z1	D369		.	.	.	2073T	S473		
TAHOE	1999	2000	7260-Z	D370		.	.	.	2073T	S473		
TAHOE	2000	2000	7653-Z	D785		.	.	.	1404A	S675		
TAHOE	2000	2000	7653-Z	D785		.	.	.	2073T	S473		
TAHOE	2000	2000	7259-Z1	D369		.	.	.	7700-Z	D792		
TAHOE	2000	2000	7260A-Z	D370MA		.	.	.	7700-Z	D792		
TAHOE	2000	2000	7260-Z	D370		.	.	.	7700-Z	D792		
TAHOE	2000	2000	7259-Z1	D369		.	.	.	7707-Z	D834		
TAHOE	2000	2000	7260A-Z	D370MA		.	.	.	7707-Z	D834		
TAHOE	2000	2000	7260-Z	D370		.	.	.	7707-Z	D834		
TAHOE	2000	2001	7653-Z	D785		.	.	.	7700-Z	D792		
TAHOE	2000	2006	7653-Z	D785		.	.	.	7707-Z	D834		
TAHOE	2002	2006	7653-Z	D785		.	.	.	7881-Z	D974		
TAHOE	2007	2007	7997-Z	D1092		.	.	.	8312-Z	D1194		
TAHOE	2008	2018	8472-Z	D1363		.	.	.	8312-Z	D1194		
TORNADO	2004	2018	8290-Z	D1176		.	.	.	1516	S751		
TRACKER	1989	1998	7305-Z	D418		.	.	.	1440	S641		
TRACKER	1996	1998	7435-Z	D556		
TRACKER	1999	2005	7680-Z	D807		.	.	.	1506	S738		
TRACKER	2000	2004	7435-Z	D556		.	.	.	1506	S738		
TRACKER	2005	2006	7559-Z	D680		.	.	.	1506	S738		
TRAILBLAZER	2002	2005	7759-Z	D882		.	.	.	7760-Z	D883		
TRAILBLAZER	2006	2009	8282-Z	D1169		.	.	.	7760-Z	D883		
TRAVERSE	2009	2017	8410-Z	D1169		.	.	.	7760-Z	D883		
TRAX	2013	2018	8667-Z	D1467	Freno de Tambor Trasero	.	.	.	1680	S1011		
TRAX	2013	2018	8667-Z	D1467	Freno de Disco Trasero	.	.	.	8668-Z	D1468		
UPLANDER	2005	2009	7980-Z	D1075		.	.	.	7999-Z	D1093		
VENTURE	1997	2005	7693-Z	D699A		.	.	.	7387-Z2	D714		
VENTURE	2000	2005	7574-Z	D699		.	.	.	7387-Z2	D714		
VENTURE	2002	2005	7720-Z	D844		.	.	.	7387-Z2	D714		
VENTURE	2002	2005	7574-Z	D699		.	.	.	7387-Z3	D814		
VENTURE	2002	2005	7693-Z	D699A		.	.	.	7387-Z3	D814		
VENTURE	2002	2005	7720-Z	D844		.	.	.	7387-Z3	D814		
ZAFIRA	2001	2006	768X-AZ	F185		.	.	.	778X-Z	F202		
ZAFIRA	2001	2006	8470-Z	D1361		.	.	.	778X-Z	F202		

MODELO Model	AÑO Inicio	AÑO Final	BALATAS DELANTERAS							BALATAS TRASERAS						
			Pastilla	Zapata	Características	AZUL	FIX	SPC	SHD	Pastilla	Zapata	Características	AZUL	FIX	SPC	SHD
CHRYSLER																
200	2011	2014	7741-Z	D866	Ø Rotor 340mm	•	•	•	7743-Z	D868	BRG	•	•	•	•	
200	2011	2014	7741-Z	D866	Ø Rotor 295mm	•	•	•	7940-Z	D1037	BRF	•	•	•	•	
200	2013	2014	7965-Z	D1058	Ø Rotor 340mm	•	•	•	7743-Z	D868	BRG	•	•	•	•	
200	2013	2014	7965-Z	D1058	Ø Rotor 295mm	•	•	•	7940-Z	D1037	BRF	•	•	•	•	
200	2015	2017	8867-Z	D1640	BRF, BRG	•	•	•	8958-Z	D1734		•	•	•	•	
300	2005	2016	8259-Z	D1149	SRT-8	•	•	•	7958-Z	D1053		•	•	•	•	
300	2005	2016	7962-Z	D1056	RWD	•	•	•	7963-Z	D1057		•	•	•	•	
300	2005	2016	7965-Z	D1058	AWD	•	•	•	7963-Z	D1057		•	•	•	•	
300M	1999	2004	7623-Z	D730		•	•	•	7438-AZ	D658		•	•	•	•	
CIRRUS	1995	2000	7530-AZ	D650		•	•	•	1481	S716		•	•	•	•	
CIRRUS	1995	2000	7530-AZ	D650		•	•	•	7438-BZ	D641		•	•	•	•	
CIRRUS	2001	2006	7744-Z	D869		•	•	•	7438-BZ	D641		•	•	•	•	
CIRRUS	2007	2009	7741-Z	D866		•	•	•	7743-Z	D868		•	•	•	•	
CIRRUS	2010	2010	7741-Z	D866		•	•	•	7940-Z	D1037		•	•	•	•	
CIRRUS	1998	2000	7530-AZ	D650	Coupe	•	•	•	1481	S698		•	•	•	•	
CONCORDE	1992	1992	7470-AZ	D591		•	•	•	7303-Z1	D512		•	•	•	•	
CONCORDE	1993	1994	7470-AZ	D591		•	•	•				•	•	•	•	
CONCORDE	1995	1997	7470-AZ	D591		•	•	•	7438-AZ	D658		•	•	•	•	
CONCORDE	1998	2004	7623-Z	D730		•	•	•	7438-AZ	D658		•	•	•	•	
CORDOBA	1977	1977				•	•	•	2089T	S445		•	•	•	•	
CORDOBA	1975	1983	7017-Z	D84		•	•	•	2089T	S445		•	•	•	•	
CROSSFIRE	2004	2008	7730-Z	D853		•	•	•	7647-Z	D779		•	•	•	•	
CROSSFIRE	2005	2006	7730-Z	D853		•	•	•				•	•	•	•	
DART	1973	1979	7017-Z	D84		•	•	•	2089T	S445		•	•	•	•	
DART	1980	1982	7017-Z	D84		•	•	•	1365	S519		•	•	•	•	
DART	1982	1982	7097-Z	D170		•	•	•	1365	S519		•	•	•	•	
IMPERIAL	1974	1975	7019-Z	D86		•	•	•				•	•	•	•	
IMPERIAL	1991	1993	7406-Z	D524		•	•	•	7303-Z1	D512		•	•	•	•	
INTREPID	1993	1994	7470-AZ	D591		•	•	•	7303-Z1	D512		•	•	•	•	
INTREPID	1995	1997	7470-AZ	D591		•	•	•	7438-AZ	D658		•	•	•	•	
INTREPID	1998	2004	7623-Z	D730		•	•	•	7438-AZ	D658		•	•	•	•	
LASER	1990	1994	7365-Z	D484		•	•	•				•	•	•	•	
LEBARON	1977	1981	7017-Z	D84		•	•	•	2089T	S445		•	•	•	•	
LEBARON	1989	1989				•	•	•	1366	S520		•	•	•	•	
LEBARON	1990	1990				•	•	•	7303-Z	D415		•	•	•	•	
LEBARON	1991	1994	7404-AZ	D522		•	•	•	1444A	S657		•	•	•	•	
LEBARON	1991	1995	7404-AZ	D522		•	•	•	7303-Z1	D512		•	•	•	•	
LEBARON	1993	1995	7404-AZ	D522		•	•	•	7438-AZ	D658		•	•	•	•	
LEBARON K	1982	1987	7134-Z	D220		•	•	•	1365	S519		•	•	•	•	
LEBARON K	1984	1986				•	•	•	1365	S519		•	•	•	•	
LHS	1994	1997	7470-AZ	D591		•	•	•	7438-AZ	D658		•	•	•	•	
LHS	1999	2001	7623-Z	D730		•	•	•	7438-AZ	D658		•	•	•	•	
MAGNUM	1980	1982	7017-Z	D84		•	•	•				•	•	•	•	
MAGNUM	1987	1988	7134-Z	D220		•	•	•				•	•	•	•	
MAGNUM	2005	2008	7962-Z	D1056		•	•	•	7963-Z	D1057		•	•	•	•	
MAGNUM	2005	2008	7965-Z	D1058		•	•	•	7963-Z	D1057		•	•	•	•	
MAGNUM	2006	2006	8259-Z	D1149		•	•	•	7958-Z	D1053		•	•	•	•	
MAGNUM	2007	2008	7962-Z	D1056		•	•	•	8292-Z	D1057		•	•	•	•	
NEW YORKER	1974	1978	7019-Z	D86		•	•	•				•	•	•	•	
NEW YORKER	1979	1983	7017-Z	D84		•	•	•	2089T	S445		•	•	•	•	
NEW YORKER	1985	1990	7134-Z	D220		•	•	•	1366	S520		•	•	•	•	
NEW YORKER	1988	1989				•	•	•	1444A	S657		•	•	•	•	
NEW YORKER	1990	1990	7134-Z	D220		•	•	•				•	•	•	•	
NEW YORKER	1991	1993	7406-Z	D524		•	•	•	1444A	S657		•	•	•	•	
NEW YORKER	1991	1993	7406-Z	D524		•	•	•	7303-Z1	D512		•	•	•	•	
NEW YORKER	1993	1993				•	•	•	1444A	S657		•	•	•	•	
NEW YORKER	1994	1996	7470-AZ	D591		•	•	•	7303-Z1	D512		•	•	•	•	
NEWPORT	1974	1979	7019-Z	D86		•	•	•	2089T	S445		•	•	•	•	
NEWPORT	1980	1981	7017-Z	D84		•	•	•	2089T	S445		•	•	•	•	
PHANTOM	1986	1989	7404-AZ	D522		•	•	•	7303-Z	D415		•	•	•	•	
PHANTOM	1987	1990	7134-Z	D220		•	•	•	7303-Z	D415		•	•	•	•	
PROWLER	1999	2001	7470-AZ	D591		•	•	•	7518-AZ	D642		•	•	•	•	
PT CRUISER	2001	2010	7716-Z	D841		•	•	•	7438-BZ	D641		•	•	•	•	
PT CRUISER	2004	2009	7716-Z	D841		•	•	•	1542	S810		•	•	•	•	
PT CRUISER	2004	2009	7716-Z	D841		•	•	•	7438-AZ	D658		•	•	•	•	
RT	1996	1997	7404-AZ	D522		•	•	•	7303-Z1	D512		•	•	•	•	
SEBRING	1995	1999	7365-Z	D484		•	•	•				•	•	•	•	
SEBRING	2000	2005	7365-Z	D484		•	•	•	7272-Z	D383		•	•	•	•	

MODELO Model	AÑO Inicio	AÑO Final	BALATAS DELANTERAS			AZUL	FIX	SFC	SHD	BALATAS TRASERAS			AZUL	FIX	SFC	SHD	FT OW
			Pastilla	Zapata	Características					Pastilla	Zapata	Características					
SEBRING	2001	2005	7741-Z	D866		•	•	•	7272-Z	D383		•	•	•			
SEBRING	2001	2005	7744-Z	D869		•	•	•	7272-Z	D383		•	•	•			
SEBRING	2001	2005	7365-Z	D484		•	•	•	7438-BZ	D641		•	•	•			
SEBRING	2001	2005	7741-Z	D866		•	•	•	7438-BZ	D641		•	•	•			
SEBRING	2001	2006	7744-Z	D869		•	•	•	7438-BZ	D641		•	•	•			
SEBRING	2003	2005	7365-Z	D484		•	•	•	1540	S800						•	
SEBRING	2003	2005	7741-Z	D866		•	•	•	1540	S800						•	
SEBRING	2003	2006	7744-Z	D869		•	•	•	1540	S800						•	
SEBRING	2007	2009	7741-Z	D866		•	•	•	1462	S919						•	
SEBRING	2007	2010	7741-Z	D866		•	•	•	7743-Z	D868		•	•	•			
SEBRING	2007	2010	7741-Z	D866		•	•	•	7940-Z	D1037		•	•	•			
SHADOW	1988	1990	7134-Z	D220		•			7303-Z	D415		•	•	•			
SHADOW	1990	1990							7303-Z	D415		•	•	•			
SHADOW	1991	1994	7406-Z	D524		•	•		7303-Z	D415		•	•	•			
SPIRIT	1989	1990	7134-Z	D220		•			1444A	S657						•	
SPIRIT	1990	1990							1366	S520						•	
SPIRIT	1990	1995	7406-Z	D524		•	•		1444A	S657						•	
SPIRIT	1991	1991	7404-AZ	D522		•	•		7303-Z1	D512		•	•	•			
SPIRIT	1991	1993	7404-AZ	D522		•	•		1444A	S657						•	
SPIRIT	1992	1994	7404-AZ	D522		•	•										
SPIRIT	1993	1993	7404-AZ	D522		•	•		7303-Z1	D512		•	•	•			
SPIRIT	1993	1995	74X6-Z	F041		•	•		7303-Z1	D512		•	•	•			
VOLARE	1976	1980	7017-Z	D84		•			2089T	S445						•	
VOLARE	1981	1982	7097-Z	D170		•											
VOLARE	1986	1989	7134-Z	D220		•											

CHRYSLER TRUCK

ASPEN	2007	2009	7991-Z	D1084		•	•	•	7869-Z	D967		•	•	•		
GRAND VOYAGER	1991	1993	7406-Z	D524		•			2168T	S538						•
GRAND VOYAGER	1991	1994	7404-AZ	D522		•	•		2168T	S538						•
GRAND VOYAGER	1991	1995	7406-Z	D524		•	•		2168T	S538						•
GRAND VOYAGER	1992	1993	7404-AZ	D522		•	•		2025	S446						•
GRAND VOYAGER	1996	1996	7470-AZ	D591		•	•		1485TT	S703						•
GRAND VOYAGER	1997	2000	7470-AZ	D591		•	•		1485ATT	S714						•
GRAND VOYAGER	1997	2000	7470-AZ	D591		•	•		7424-Z	D544		•	•	•		
PACIFICA	2004	2008	7898-Z	D997		•	•		7899-Z	D998		•	•	•		
PACIFICA	2017	2018	8800-Z	D1589		•	•									
TOWN & COUNTRY	1974	1978	7019-Z	D86		•		•								
TOWN & COUNTRY	1979	1982	7017-Z	D84		•			2089T	S445						•
TOWN & COUNTRY	1990	1993	7404-AZ	D522		•	•		2168T	S538						•
TOWN & COUNTRY	1994	1994	7404-AZ	D522		•	•		2025	S446						•
TOWN & COUNTRY	1994	1994	7406-Z	D524		•	•		2025	S446						•
TOWN & COUNTRY	1996	1996	7470-AZ	D591		•	•		1485TT	S703						•
TOWN & COUNTRY	1997	2000	7470-AZ	D591		•	•		1485ATT	S714						•
TOWN & COUNTRY	1998	2000	7470-AZ	D591		•	•		7424-Z	D544		•	•	•		
TOWN & COUNTRY	2001	2007	7732-Z	D856		•	•		1485ATT	S714						•
TOWN & COUNTRY	2001	2007	7733-Z	D857		•	•		7734-Z	D858		•	•	•		
TOWN & COUNTRY	2008	2008	8389-Z	D1273		•	•		8438-Z	D1326		•	•	•		
TOWN & COUNTRY	2008	2012	8703-Z	D1327		•	•		8438-Z	D1326		•	•	•		
TOWN & COUNTRY	2009	2011	8481-Z	D1327	HD BRAKES	•	•		8438-Z	D1326		•	•	•		
TOWN & COUNTRY	2012	2014	8703-Z	D1327	BRE	•	•		8811-Z	D1596		•	•	•		
TOWN & COUNTRY	2012	2016	8703-Z	D1327	BRE	•	•		7945-Z	D1041		•	•	•		
TOWN & COUNTRY	2013	2016	8800-Z	D1589	Ø Rotor 330mm, HD Brakes	•	•		8811-Z	D1596	Ø Rotor 328mm	•	•	•		
VOYAGER	1984	1990	7164-Z	D259		•			2168T	S538						•
VOYAGER	1991	1994	7404-AZ	D522		•	•		2168T	S538						•
VOYAGER	1991	1994	7406-Z	D524		•	•		2168T	S538						•
VOYAGER	1996	2000	7470-AZ	D591		•	•		7424-Z	D544		•	•	•		
VOYAGER	1996	2003	7470-AZ	D591		•	•		1485ATT	S714						•
VOYAGER	2001	2008	7732-Z	D856		•	•		1485ATT	S714						•
VOYAGER	2001	2008	7732-Z	D856		•	•		7734-Z	D858		•	•	•		
VOYAGER	2001	2008	7733-Z	D857		•	•		7734-Z	D858		•	•	•		

DODGE

2000	1991	1993	7365-Z	D484	GTX	•	•									
A100	1976	1979	7019-Z	D86		•	•	•	2089T	S445						•
ATOS	2001	2001	8852-Z	D1148		•	•		1379	S707						•
ATOS	2002	2012	8253-Z	D1142		•	•		1379	S707						•
ATTITUDE	2006	2011	8266-Z	D1156		•	•		1616	S910						•
ATTITUDE	2008	2011	8266-Z	D1156		•	•		8267-Z	D1157		•	•	•		
ATTITUDE	2012	2014	8X51-Z	F386		•	•		1616	S1021						•

MODELO Model	AÑO Inicio	AÑO Final	BALATAS DELANTERAS							BALATAS TRASERAS							FT OW	
			Pastilla	Zapata	Características	AZUL	FIX	SPC	SHD	Pastilla	Zapata	Características	AZUL	FIX	SPC	SHD		
ATTITUDE	2012	2014	8X51-Z	F386					8428-Z5	D1812								
ATTITUDE	2015	2018	8956-Z	D1731					1624	S924								
AVENGER	2008	2009	7741-Z	D866					1462	S919								
AVENGER	2008	2014	7741-Z	D866	SXT, RT				7743-Z	D868								
AVENGER	2008	2014	7741-Z	D866	SE				7940-Z	D1037								
AVENGER	2011	2011	7741-Z	D866	SXT				1462	S919								
AVENGER	2013	2014	7965-Z	D1058					7743-Z	D868								
CALIBER	2007	2007	8338-Z	D866					1462	S919								
CALIBER	2007	2012	7741-Z	D866	SXT				7940-Z	D1037								
CALIBER	2008	2009	7965-Z	D1058	SRT-4				7743-Z	D868								
CALIBER	2008	2012	7741-Z	D866	SE				1462	S919								
CHALLENGER	2008	2015	8259-Z	D1149	SRT8				7958-Z	D1053								
CHALLENGER	2009	2016	7965-Z	D1058	Versión R/T				7963-Z	D1057								
CHALLENGER	2012	2016	7962-Z	D1056	SXT, SE				7963-Z	D1057								
CHALLENGER	2015	2016	8259-Z	D1149	Scat Pack				7958-Z	D1053								
CHALLENGER	2016	2016			SRT Hellcat 6.2L SC				7958-Z	D1053								
CHARGER	1976	1978	7017-Z	D84					2089T	S445								
CHARGER	1983	1987							1365	S519								
CHARGER	2006	2016	7962-Z	D1056	SXT 3.5L / RT Daytona, RWD				7963-Z	D1057								
CHARGER	2006	2014	7965-Z	D1058	HD Brakes				7963-Z	D1057								
CHARGER	2007	2010	7965-Z	D1058	3.6L Police / 5.7L / SRT-8				8292-Z	D1057								
CHARGER	2012	2014	8259-Z	D1149	SRT-8 6.4L				7958-Z	D1053								
CHARGER	2014	2016	8998-Z	D1767	Police				8997-Z	D1766								
CHARGER	2016	2016	8513-Z	D1405	SRT Hellcat 6.2L				7958-Z	D1053								
COLT	1992	1994	7365-Z	D484					7272-Z	D383								
DART	2013	2016	8867-Z	D1640					8875-Z	D1647								
DART K	1982	1982	7017-Z	D84					1365	S519								
DART K	1982	1982	7097-Z	D170					1365	S519								
DART K	1983	1989	7134-Z	D220					1365	S519								
DAYTONA	1988	1988							1366	S520								
DAYTONA	1989	1990							7303-Z	D415								
DAYTONA	1990	1990							1365	S519								
DAYTONA	1991	1991	7404-AZ	D522					7303-Z1	D512								
DAYTONA	1991	1993	7404-AZ	D522														
DYNASTY	1988	1989							1366	S520								
DYNASTY	1991	1991	7406-Z	D524					7303-Z1	D512								
DYNASTY	1991	1993	7406-Z	D524					1444A	S657								
i10	2012	2014	8815-Z	D1601					1X89	FT080								
MAGNUM K	1983	1988	7134-Z	D220					1365	S519								
MIRADA	1980	1983	7017-Z	D84					2089T	S445								
MONACO	1975	1976	7019-Z	D86														
MONACO	1977	1978							2089T	S445								
NEON	1995	1996	7511-AZ	D633					1473	S689								
NEON	1995	1996	7518-AZ	D642					1473	S689								
NEON	1995	1999	7518-AZ	D642	RT				7438-BZ	D641								
NEON	2000	2005	7623-Z	D730					1473	S689								
NEON	2000	2005	7623-Z	D730					7438-BZ	D641								
NEON	2003	2005	7716-Z	D841	SRT				7438-AZ	D658								
NEON	2017	2018	9X49-Z	F529														
R300	1972	1974	7019-Z	D86					2140AT	S358								
ROYAL MONACO	1977	1977	7019-Z	D86														
ST. REGIS	1979	1981	7017-Z	D84					2089T	S445								
STEALTH	1991	1993	7412-Z	D530					7414-Z	D532								
STEALTH	1991	1996	7412-Z	D530					7272-Z	D383								
STRATUS	1995	2000	7530-AZ	D650					1481	S716								
STRATUS	1995	2000	7530-AZ	D650					7438-BZ	D641								
STRATUS	2001	2005	7365-Z	D484					7272-Z	D383								
STRATUS	2001	2005	7741-Z	D866					7272-Z	D383								
STRATUS	2001	2006	7744-Z	D869					1540	S800								
STRATUS	2001	2006	7744-Z	D869					7438-BZ	D641								
VERNA	2000	2005	7376-Z	D497					1495	S808								
VERNA	2004	2005	7293-Z	D404					1495	S808								
VERNA	2006	2006	7293-Z	D404					1379	S707								
VISION	2015	2018	7W04-Z	F498					1695	S1029								
DODGE TRUCK																		
B100	1973	1980	7019-Z	D86					2089T	S445								
B150	1981	1983	7019-Z	D86					2089T	S445								
B150	1984	1984	7179-AZ	D269														
B150	1994	1994	7179-AZ	D269														

MODELO Model	AÑO Inicio	AÑO Final	BALATAS DELANTERAS			AZUL	FIX	SFC	SHD	BALATAS TRASERAS			AZUL	FIX	SFC	SHD	FT OW
			Pastilla	Zapata	Características					Pastilla	Zapata	Características					
B1500	1995	1997	7179-AZ	D269		•											
B1500	1998	1998	7627-Z	D758		•			2171T	S583							•
B1500	1998	1998	7627-Z	D758		•			2182T	S734							•
B200 VAN	1973	1974	7019-Z	D86		•											
B250	1981	1983	7019-Z	D86		•			2089T	S445							•
B250	1984	1984	7179-AZ	D269		•			2025	S446							•
B250	1985	1989	7179-AZ	D269		•			2140AT	S358							•
B250	1994	1994	7179-AZ	D269		•			2140AT	S358							•
B250	1994	1994	7179-AZ	D269		•			2146AT	S357							•
B2500	1995	1997	7179-AZ	D269		•			2140AT	S358							•
B2500	1995	1997	7179-AZ	D269		•			2146AT	S357							•
B2500	1998	1998	7677-Z	D655		•			2171T	S583							•
B2500	1998	1998	7677-Z	D655		•			2182T	S734							•
B300	1972	1972							2146AT	S357							•
B300	1975	1975	7019-Z	D86		•			2140AT	S358							•
B300	1975	1980	7019-Z	D86		•			2146AT	S357							•
B300	1978	1980	7019-Z	D86		•			2140AT	S358							•
B300 VAN	1973	1974	7019-Z	D86		•			2146AT	S357							•
B350	1981	1983	7019-Z	D86		•			2140AT	S358							•
B350	1985	1989	7019-Z	D86		•			2140AT	S358							•
B350	1985	1989	7019-Z	D86		•			2146AT	S357							•
B3500	1995	1998	7179-AZ	D269		•			2140AT	S358							•
B3500	1995	1998	7179-AZ	D269		•			2146AT	S357							•
CARAVAN	1987	1988	7164-Z	D259		•			2168T	S538							•
CARAVAN	1991	1993	7404-AZ	D522		•	•		2168T	S538							•
CARAVAN	1991	1994	7404-AZ	D522		•	•		2025	S446							•
CARAVAN	1994	1994	7406-Z	D524		•	•		2025	S446							•
CARAVAN	1996	1996	7470-AZ	D591		•	•		1485TT	S703							•
CARAVAN	1996	2000	7470-AZ	D591		•	•		1485ATT	S714							•
CARAVAN	2001	2004	7732-Z	D856		•	•		1485ATT	S714							•
CARAVAN	2003	2007	7732-Z	D856		•	•		7734-Z	D858		•	•				•
CARAVAN	2003	2007	7733-Z	D857	Con clip para pistón	•	•		7734-Z	D858		•	•				•
CB300	1976	1980	7019-Z	D86		•	•		2140AT	S358							•
CB300	1976	1980	7019-Z	D86		•	•		2146AT	S357							•
D100	1973	1974	7019-Z	D86		•											
D100	1975	1979	7019-Z	D86		•	•		2089T	S445							•
D150	1979	1983	7019-Z	D86		•	•		2089T	S445							•
D150	1984	1990	7179-AZ	D269		•											
D200	1972	1972							2140AT	S358							•
D200	1973	1974	7019-Z	D86		•	•		2146AT	S357							•
D200	1975	1980	7019-Z	D86		•	•		2140AT	S358							•
D200	1975	1980	7019-Z	D86		•	•		2146AT	S357							•
D250	1983	1983	7019-Z	D86		•	•		2140AT	S358							•
D250	1984	1984	7179-AZ	D269		•	•		2146AT	S357							•
D250	1989	1989	7019-Z	D86		•	•		2146AT	S357							•
D250	1990	1990	7179-AZ	D269		•	•		2089T	S445							•
D300	1972	1972	7019-Z	D86		•	•		2140AT	S358							•
D300	1973	1980	7019-Z	D86		•	•		2140AT	S358							•
D300	1980	1980	7019-Z	D86		•	•		2146AT	S357							•
D350	1980	1983	7019-Z	D86		•	•		2146AT	S357							•
D350	1981	1987	7179-AZ	D269		•	•		2140AT	S358							•
D350	1989	1990	7179-AZ	D269		•	•		2089T	S445							•
D400	1978	1981							2140AT	S358							•
D450	1980	1981	7019-Z	D86		•	•		2140AT	S358							•
DAKOTA	1987	1990	7237-AZ	D344		•			2089T	S445							•
DAKOTA	1987	1990	7237-AZ	D344		•			2168T	S538							•
DAKOTA	1991	1992	7410-Z	D529		•			2089T	S445							•
DAKOTA	1991	1992	7410-Z	D529		•			2168T	S538							•
DAKOTA	1993	1998	7410-AZ	D593		•	•		2089T	S445							•
DAKOTA	1993	1998	7410-AZ	D593		•	•		2168T	S538							•
DAKOTA	1999	1999	7616-Z	D746		•	•		2089T	S445							•
DAKOTA	1999	1999	7616-Z	D746		•	•		2168T	S538							•
DAKOTA	2000	2002	7616-Z1	D820		•	•		2168T	S538							•
DAKOTA	2002	2002	7616-Z1	D820		•	•		2182T	S734							•
DAKOTA	2003	2004	7861-Z	D962		•			2182T	S734							•
DAKOTA	2003	2004	7861-Z	D962		•											
DAKOTA	2005	2012	7991-Z	D1084		•	•		1582	S922							•
DAKOTA	2005	2012	7991-Z	D1084		•	•		7869-Z	D967		•	•				•
DURANGO	1998	1999	7616-Z	D746		•	•		2182T	S734							•
DURANGO	2000	2002	7616-Z1	D820		•	•		2182T	S734							•

MODELO Model	AÑO Inicio	AÑO Final	BALATAS DELANTERAS			AZUL	FIX	SPC	SHD	BALATAS TRASERAS			AZUL	FIX	SPC	SHD	FT OW
			Pastilla	Zapata	Características					Pastilla	Zapata	Características					
DURANGO	2004	2006	7984-Z	D1079		•	•		7869-Z	D967		•					
DURANGO	2007	2009	7991-Z	D1084		•			7869-Z	D967		•					
DURANGO	2011	2017	8655-Z	D1455			•	•	8698-Z	D1498			•				
GRAND CARAVAN	1987	1990							2168T	S538						•	
GRAND CARAVAN	1988	1988							2168T	S538						•	
GRAND CARAVAN	1991	1993	7404-AZ	D522		•	•		2168T	S538						•	
GRAND CARAVAN	1991	1994	7404-AZ	D522		•	•		2025	S446						•	
GRAND CARAVAN	1994	1994	7406-Z	D524		•	•		2168T	S538						•	
GRAND CARAVAN	1996	1996	7470-AZ	D591		•	•		1485TT	S703						•	
GRAND CARAVAN	1997	2000	7470-AZ	D591		•	•		1485ATT	S714						•	
GRAND CARAVAN	1998	2000	7470-AZ	D591		•	•		7424-Z	D544		•				•	
GRAND CARAVAN	2017	2018	8800-Z	D1589				•	8811-Z	D1596			•				
H-100	1997	2007	8247-Z	D1137	Gasolina	•		•	1X24	FT009						•	
H-100	2008	2013	7Y35-Z	F278	Diésel	•		•	1399	S1026						•	
H-100 VAN	2008	2008	8247-Z	D1137		•		•	1399	S1026						•	
H-100 VAN	2010	2013	8775-Z	D1566		•		•	1X44	FT054						•	
JOURNEY	2007	2011	8703-Z	D1327				•	8438-Z	D1326		•				•	
JOURNEY	2009	2011	8481-Z	D1327	R/T	•		•	8438-Z	D1326		•				•	
JOURNEY	2012	2018	8800-Z	D1589				•	8811-Z	D1596			•			•	
NITRO	2007	2010	8389-Z	D1273	SXT	•		•	8390-Z	D1274		•				•	
NITRO	2011	2013	8481-Z	D1327		•		•	8390-Z	D1274		•				•	
RAIDER	1987	1989	7241-Z	D349		•		•	1370	S524						•	
RAM 1500	1994	1998	7259-Z1	D369		•		•	2134BT	S652						•	
RAM 1500	1999	1999	7659-Z	D789	4WD	•		•	2134BT	S652						•	
RAM 1500	2000	2000	7627-Z	D758		•		•	2182T	S734						•	
RAM 1500	2000	2001	7718-Z	D842		•		•	2182T	S734						•	
RAM 1500	2002	2003	7774-Z	D897		•		•	7775-Z	D898		•				•	
RAM 1500	2004	2005	7984-Z	D1079		•		•	7869-Z	D967		•				•	
RAM 1500	2004	2005	7992-Z	D1085	SRT10	•		•	7774-Z	D897		•				•	
RAM 1500	2006	2008	7864-Z	D965	Extended Crew Cab	•		•	7865-Z	D1077		•				•	
RAM 1500	2006	2018	7991-Z	D1084		•		•	7869-Z	D967		•				•	
RAM 1500 VAN	1999	2002	7627-Z	D758		•		•	2182T	S734						•	
RAM 1500 VAN	2003	2003	7866-Z	D966		•		•	7869-Z	D967		•				•	
RAM 2500	1994	1998	7260-Z	D370		•		•								•	
RAM 2500	1994	1998	7339-Z	D459		•		•								•	
RAM 2500	1998	1999	7260A-Z	D370MA		•		•								•	
RAM 2500	2001	2001	7694-Z	D821		•		•	7752-Z	D1096		•				•	
RAM 2500	2001	2002	7694-Z1	D859		•		•	7752-Z	D1096		•				•	
RAM 2500	2003	2008	7864-Z	D965		•		•	7865-Z	D1077		•				•	
RAM 2500 VAN	1999	2002	7677-Z	D655		•		•	2182T	S734						•	
RAM 3500	1994	1999	7339-Z	D459		•		•								•	
RAM 3500	2001	2002	7694-Z1	D859		•		•	7752-Z	D1096		•				•	
RAM 3500	2003	2008	7864-Z	D965		•		•	7865-Z	D1077		•				•	
RAM 3500 VAN	1999	2002	7677-Z	D655		•		•	2182T	S734						•	
RAM 4000	2009	2012	7864-Z	D965		•		•	7865-Z	D1077		•				•	
RAM 4000	2009	2012	8446-Z	D1335		•		•	8446-Z	D1335		•				•	
RAM 4000	2009	2017	8507-Z	D1399		•		•	8508-Z	D1400		•				•	
RAM 4500	2008	2013	8446-Z	D1335		•		•	8446-Z	D1335		•				•	
RAM 50	1987	1993	7241-Z	D349		•		•	1370	S524						•	
RAM 5500	2008	2010	8446-Z	D1335		•		•	8446-Z	D1335		•				•	
RAMCHARGER	1980	1984	7019-Z	D86		•		•	2089T	S445						•	
RAMCHARGER	1994	1998	7179-AZ	D269		•		•								•	
RAMCHARGER	1999	1999	7259-Z1	D369		•		•	2134BT	S652						•	
RAMCHARGER	1999	1999	7659-Z	D789		•		•	2134BT	S652						•	
RAMCHARGER	2000	2001	7694-Z	D821		•		•								•	
SPRINTER 2500	2002	2006	8246-Z	D1136				•	7909-Z	D1006			•			•	
SPRINTER 2500	2002	2006	7848A-Z	D949				•	7909-Z	D1006			•			•	
SPRINTER 2500	2002	2006	7848-Z	D949				•	7909-Z	D1006			•			•	
SPRINTER 2500	2002	2006	7909B-Z	D1006B				•	7909-Z	D1006			•			•	
SPRINTER 2500	2002	2006	8246-Z	D1136				•								•	
SPRINTER 2500	2002	2006	7848-Z	D949				•								•	
SPRINTER 2500	2002	2006	7849-Z	D950				•								•	
SPRINTER 2500	2002	2006	8246-Z	D1136				•	8431A-Z	D1317			•			•	
SPRINTER 2500	2007	2016	8430A-Z	D1316				•	8431A-Z	D1317			•			•	
SPRINTER 3500	2002	2006	8246-Z	D1136				•	8246-Z	D1136			•			•	
SPRINTER 3500	2002	2006	7848-Z	D949	Rin 16"			•					•			•	
SPRINTER 3500	2002	2006	7848-Z	D949				•	7848-Z	D949			•			•	
SPRINTER 3500	2002	2006	7849-Z	D950				•	7848-Z	D949			•			•	
SPRINTER 3500	2002	2006	7848-Z	D949				•					•			•	
SPRINTER 3500	2002	2006	8246-Z	D1136				•	7909-Z	D1006			•			•	

MODELO Model	AÑO Inicio	AÑO Final	BALATAS DELANTERAS			AZUL	FIX	SFC	SHD	BALATAS TRASERAS			AZUL	FIX	SFC	SHD	FT OW
			Pastilla	Zapata	Características					Pastilla	Zapata	Características					
SPRINTER 3500	2007	2016	7849-Z	D950	DRW					•	7848-Z	D949					
SPRINTER 3500	2007	2016	8246-Z	D1136						•	8431A-Z	D1317					
SPRINTER 3500	2007	2016	8383-Z	D1268	DRW					•	8432-Z	D1318					
SPRINTER 3500	2007	2016	79W3A-Z	F314						•	79W4A-Z	F315					
W150	1980	1983	7019-Z	D86		•				•	2089T	S445					•
W150	1984	1984	7179-AZ	D269		•											
W200	1980	1980									2140AT	S358					•
W250	1981	1981									2140AT	S358					•
W250	1990	1990	7019-Z	D86		•				•	2146AT	S357					•
W250	1990	1990	7081-Z	D149		•				•	2146AT	S357					•
W300	1980	1980									2140AT	S358					•
W350	1983	1983	7019-Z	D86		•				•	2140AT	S358					•
W400	1977	1977	7081-Z	D149		•				•	2140AT	S358					•
EAGLE																	
TALON	1990	1995	7365-Z	D484		•	•				7414-Z	D532		•			
TALON	1993	1995	7412-Z	D530		•	•				7414-Z	D532		•			
TALON	1995	1996	7365-Z	D484		•	•										
TALON	1995	1996	7412-Z	D530		•	•										
TALON	1996	1998	7365-Z	D484		•	•				7272-Z	D383		•	•		
TALON	1996	1998	7412-Z	D530		•	•				7272-Z	D383		•	•		
VISION	1993	1997	7470-AZ	D591		•	•				7438-AZ	D658		•	•		
VISTA	1992	1992	7365-Z	D484		•	•				7272-Z	D383		•	•		
EAGLE TRUCK																	
SUMMIT	1992	1992									7272-Z	D383		•	•		
SUMMIT	1993	1996	7365-Z	D484		•	•				7272-Z	D383		•	•		
FAW																	
F1	2008	2009	8720-Z	D1511		•											
F4	2008	2010	8721-Z	D1512		•	•										
F5	2008	2009	7695-Z	D822		•	•				1515	S750					•
FAW TRUCK																	
GF 8	2006	2010	771XZ	F204		•											
GF 900	2006	2010	754X-Z	F059		•											
FIAT																	
500	2012	2017	8777-Z	D1568			•				8778-Z	D1569		•			
500	2013	2017	7Y14-Z	F245	Abarth	•	•				8778-Z	D1569		•			
MOBI	2017	2018	7Y55-Z	F533			•										
PALIO	2004	2010	7X54-Z	D298		•	•										
PANDA	2007	2009	8831-Z	D1619		•											
TEMPRA	1990	2000									7X54-AZ	D298		•	•		
TEMPRA	1990	2000	7X54A-Z	D298		•	•										
UNO	2014	2017	71Y4-Z	F450			•				1695	S1029					•
FIAT TRUCK																	
DUCATO	2008	2010									9017-Z	D1490			•		
DUCATO	2008	2015	8748A-Z	D1540		•				•	7Y87-Z	F222		•		•	
STRADA	2007	2010	8831-Z	D1619	Adventure STX-L	•											
STRADA	2012	2016	7W04-Z	F498	Crew Cab	•	•				2Y20	FT111					•
STRADA	2012	2016	9195-Z	D1970	Club Cab	•		•									
FORD																	
ASPIRE	1994	1997	7219-Z1	D466		•											
CONTOUR	1995	2000	7528-Z	D648		•	•				1479	S696					•
CONTOUR	1998	2000	7528-Z	D648		•	•				7541-Z	D661		•	•		
CONTOUR	1999	2000	7528-Z	D648		•	•				1504	S736					•
CONTOUR	2000	2000	7672-AZ	D801		•					1479	S696					•
CONTOUR	2000	2000	7672-AZ	D801		•					1504	S736					•
CONTOUR	2000	2000	7672-AZ	D801		•					7541-Z	D661		•	•		
COUGAR	1971	1973	776-AZ	D34		•											
COUGAR	1974	1975	788-Z	D50		•											
COUGAR	1981	1983	7072-AZ1	D152		•											
COUGAR	1985	1988	7072-BZ	D310		•											
COUGAR	1985	1988	7072-Z	D181		•											
COUGAR	1989	1992	7304-Z	D417		•					1396	S618					•
COUGAR	1993	1996	7478-Z	D600		•	•				1396	S618					•
COUGAR	1993	1997	7478-Z	D600		•	•				7477-Z	D599		•	•		

MODELO Model	AÑO Inicio	AÑO Final	BALATAS DELANTERAS							BALATAS TRASERAS							FT OW
			Pastilla	Zapata	Características	AZUL	FIX	SPC	SHD	Pastilla	Zapata	Características	AZUL	FIX	SPC	SHD	
COUGAR	1999	2000	7528-Z	D648		•	•		7541-Z	D661		•	•				
COUGAR	2000	2000	7672-AZ	D801		•			7541-Z	D661		•	•				
COUGAR	2001	2002	7528-Z	D648		•	•		1504	S736							•
COUGAR	2001	2002	7672-AZ	D801		•			1504	S736							•
COUNTRY SQUIRE	1987	1989	7082-Z	D199		•	•										
COUNTRY SQUIRE	1990	1991	7082-AZ	D150		•											
COUNTRY SQUIRE	1990	1991							2080T	S264							•
CROWN VICTORIA	1976	1978	7013-Z	D50		•											
CROWN VICTORIA	1992	1993	7082-AZ	D150		•			7424-Z	D544		•	•				
CROWN VICTORIA	1992	1994	7082-Z	D199		•	•		7424-Z	D544		•	•				
CROWN VICTORIA	1995	1995	7537-Z1	D678		•	•		7424-Z	D544		•	•				
CROWN VICTORIA	1996	1997	7537-Z1	D678		•	•		7555-Z	D674		•	•				
CROWN VICTORIA	1997	1997	7537-Z1	D678		•	•		7610-Z	D674		•	•				
CROWN VICTORIA	1998	2002	7617-Z	D748		•	•		7610-Z	D674		•	•				
CROWN VICTORIA	2000	2001	7617-Z	D748		•	•		7555-Z	D674		•	•				
CROWN VICTORIA	2002	2002	7834-Z	D931		•	•		7610-Z	D674		•	•				
CROWN VICTORIA	2003	2011	7834-Z	D931		•	•		7835-Z	D932		•	•				
ESCORT	1981	1984	7106-Z	D179		•											
ESCORT	1985	1986							1350	S501							•
ESCORT	1985	1987	7106-Z	D179		•			1350	S501							•
ESCORT	1991	1993	7219-Z1	D466		•											
ESCORT	1991	1996	7353-Z	D473		•	•		7338-Z	D458		•					
ESCORT	1992	1992	7219-Z1	D466		•											
ESCORT	1992	1992	7353-Z	D473		•	•										
ESCORT	1997	2003	7353-Z	D473		•	•		1407	S721							•
ESCORT	2000	2003	7353-Z	D473		•	•		7514-Z1	D663		•	•				
FAIRMONT	1978	1983	7072-AZ1	D152		•											
FIESTA	1983	1989							1X81	FT024							•
FIESTA	1998	2000	75X9-Z	F062		•	•		1664	S993							•
FIESTA	2000	2002	8660-Z	D1460		•	•		1664	S993							•
FIESTA	2000	2010	75X6-Z	F093		•	•		1664	S993							•
FIESTA	2011	2017	8653-Z	D1454		•	•		1437	S984							•
FIESTA	2014	2016			ST				7763-Z	D886		•	•				•
FIESTA IKON	2002	2007	75X6-Z	F093		•	•		1X81	FT024							•
FIESTA IKON	2013	2015	8289-Z	D1175		•	•										
FIGO	2016	2018	8X53-Z	F520		•	•		1437	S984							•
FIVE HUNDRED	2005	2007	7975-Z	D1070		•	•		7976-Z	D1071		•	•				•
FOCUS	2000	2004	7690-AZ	D816		•	•		1513	S747							•
FOCUS	2000	2004	7690-Z	D816		•			7763-Z	D886		•	•				•
FOCUS	2002	2004	7871-Z	D970		•			7763-Z	D886		•	•				•
FOCUS	2004	2007	7947-Z	D1044		•	•		1513	S747							•
FOCUS	2004	2007	7947-Z	D1044		•	•		7763-Z	D886		•	•				•
FOCUS	2007	2010	7947-Z	D1044	Sport	•	•		7957-Z1	D1095		•	•				•
FOCUS	2008	2011	8450-Z	D1339	ST		•		1513	S747							•
FOCUS	2012	2016	7947-Z	D1044	Freno de Tambor Trasero	•	•		1674	S1004							•
FOCUS	2012	2016	7947-Z	D1044		•	•		7957-Z1	D1095		•	•				•
FOCUS	2013	2016	8896-Z	D1668	ST		•		7957-Z1	D1095		•	•				•
FUSION	2006	2012	8277-Z	D1164		•	•		8272-Z	D1161		•	•				
FUSION	2011	2011	8277-Z	D1164		•	•		8488-Z	D1377		•	•				
FUSION	2013	2017	8882-Z	D1653		•	•		8893-Z	D1665							
GHIA	1990	1994	7106-Z1	D257		•	•		1350	S501							•
GRANADA	1976	1980	7027-Z	D91		•											
GRANADA	1981	1982	7072-AZ1	D152		•											
GRAND MARQUIS	1975	1975	788-Z	D50		•											
GRAND MARQUIS	1975	1978	7013-Z	D50		•											
GRAND MARQUIS	1979	1991	7082-AZ	D150		•											
GRAND MARQUIS	1980	1994	7082-Z	D199		•	•										
GRAND MARQUIS	1991	1994	7378-Z	D499		•	•		7424-Z	D544		•	•				
GRAND MARQUIS	1995	1995	7537-Z1	D678		•	•		7424-Z	D544		•	•				
GRAND MARQUIS	1996	1999	7537-Z1	D678		•	•		7555-Z	D674		•	•				
GRAND MARQUIS	1998	2002	7617-Z	D748		•	•		7610-Z	D674		•	•				
GRAND MARQUIS	2003	2011	7834-Z	D931		•	•		7835-Z	D932		•	•				
KA	2001	2008	75X6-Z	F093		•	•		1664	S993							•
LTD	1980	1980	7013-Z	D50		•			2080TT	S264							•
LTD	1980	1981	7082-AZ	D150		•			2080TT	S264							•
LTD	1982	1982	7082-Z	D199		•	•										
LTD	1985	1986	7072-BZ	D310		•											
LTD	1985	1986	7082-AZ	D150		•											
LTD	1985	1986	7072-Z	D181		•											
LTD CROWN VICTORIA	1987	1991	7082-AZ	D150		•											

MODELO Model	AÑO Inicio	AÑO Final	BALATAS DELANTERAS			AZUL	FIX	SFC	SHD	BALATAS TRASERAS			AZUL	FIX	SFC	SHD	FT OW
			Pastilla	Zapata	Características					Pastilla	Zapata	Características					
LTD CROWN VICTORIA	1990	1991	7082-Z	D199		•	•		2080T	S264						•	
MONDEO	2001	2007	7789-Z	D910		•	•		7790-Z	D911		•	•				
MUSTANG	1971	1973	776-AZ	D34		•											
MUSTANG	1979	1979	7072-AZ1	D152		•											
MUSTANG	1982	1983	7072-AZ1	D152		•											
MUSTANG	1987	1992	7072-BZ	D310		•											
MUSTANG	1987	1992	7072-Z	D181		•											
MUSTANG	1994	1998	7478-Z	D600		•	•		7524-Z	D627		•					
MUSTANG	1994	2004	7300-Z	D412		•			7524-Z	D627		•					
MUSTANG	1999	1999	7675-Z	D804	Convertible	•	•		7524-Z	D627		•					
MUSTANG	1999	2004	7675-Z	D804	GT	•	•		7504-Z	D627		•	•				
MUSTANG	2005	2014	7986-Z	D1081	GT / Coupe / Convertible	•	•		7987-Z	D1082		•	•				
MUSTANG	2007	2015	7902-Z	D1001	GT Brembo Man Trans	•	•		7987-Z	D1082		•	•				
MUSTANG	2015	2017	9020-Z	D1791		•			9022-Z	D1793			•				
MYSTIQUE	1994	2000	7528-Z	D648		•	•		1479	S696						•	
MYSTIQUE	1995	2000	7528-Z	D648		•	•		7541-Z	D661		•	•				
MYSTIQUE	1998	1999	7672-AZ	D801		•			7541-Z	D661		•	•				
MYSTIQUE	1999	2000	7528-Z	D648		•	•		1504	S736						•	
MYSTIQUE	1999	2000	7672-AZ	D801		•			1504	S736						•	
POLICE	2013	2016	8881-Z	D1611	Interceptor Sedan			•	8825-Z	D1612				•			
PROBE	1989	1997	7515-Z	D637		•											
PROBE	1993	1993	7463-Z	D583		•											
TAURUS	1986	1991	7222-Z	D324		•											
TAURUS	1990	1993	7308-AZ	D421MA		•			7489-Z	D610		•	•				
TAURUS	1994	1994	7479-Z	D601		•	•		7489-Z	D610		•	•				
TAURUS	1995	1999	7476-Z	D598		•			7489-Z	D610		•	•				
TAURUS	1999	2000	7479-Z	D601		•	•		7489-Z	D610		•	•				
TEMPO	1984	1984	7106-Z	D179		•			1350	S501						•	
THUNDERBIRD	1974	1976	7013-Z	D50		•											
THUNDERBIRD	1980	1982	7072-AZ1	D152		•											
THUNDERBIRD	1993	1997	7478-Z	D600		•	•		1396	S618						•	
THUNDERBIRD	1993	1997	7478-Z	D600		•	•		7477-Z	D599		•	•				
THUNDERBIRD	2002	2005	7676-Z	D805		•	•		7477-Z	D599		•	•				
TOPAZ	1984	1994	7106-Z1	D257		•	•		1350	S501						•	

FORD TRUCK

AEROSTAR	1986	1990	7224-Z	D326		•			2089AT	S581						•
AEROSTAR	1990	1993	7125-AZ	D387		•			2089AT	S581						•
AEROSTAR	1993	1997	7488-Z	D607		•			2089AT	S581						•
B100	1980	1981	788-Z	D50		•			2089T	S445						•
B150	1982	1985	788-Z	D50		•										
B200	1975	1980	7019-Z	D86		•	•		2089T	S445						•
B200	1985	1985	7009-Z	D76		•										
B200	1986	1989	7220-Z	D320		•										
B200	1990	1992	788-Z	D50		•										
BRONCO	1976	1977	788-Z	D50		•										
BRONCO	1987	1993	7361-Z	D375		•	•		2141AT	S582						•
BRONCO	1994	1996	7503-Z	D632		•	•		2141AT	S582						•
BRONCO	1997	1997	7503-Z	D632		•	•		2141AT	S582						•
BRONCO II	1984	1985	7125-Z1	D249		•	•									
BRONCO II	1986	1990	7224-Z	D326		•										
BRONCO II	1988	1990	7125-AZ	D387		•										
COURIER	2001	2005	7529-Z	D649		•			1664	S993						•
COURIER	2001	2005	75X6-Z	F093		•	•		1664	S993						•
COURIER	2001	2009	75X6-Z	F093		•	•		1504	S736						•
COURIER	2001	2012	7529-Z	D649		•			1504	S736						•
E SUPER DUTY	1996	2002	7299-Z	D411		•	•		7299-Z	D411		•	•			
E SUPER DUTY	1999	2000	7535-Z	D655		•	•		7299-Z	D411		•	•			
E-100	1975	1983	788-Z	D50		•										
E-150	2006	2007	7948-Z	D1045		•	•		7949-Z	D1046		•	•			
E-150	2007	2007	7535-Z	D655		•	•		7673-Z	D802		•	•			
E-150	2007	2007	7948-Z	D1045		•	•		7673-Z	D802		•	•			
E-150	2007	2007	7535-Z	D655		•	•		7949-Z	D1046		•	•			
E-150	2008	2014	8440-Z	D1328		•			8441-Z	D1329				•		
E-150 ECONOLINE	1986	1993	7361-Z	D375		•	•		2141AT	S582						•
E-150 ECONOLINE	1988	1990	7264-Z	D375		•										
E-150 ECONOLINE	1994	1996	7503-Z	D632		•	•		2141AT	S582						•
E-150 ECONOLINE	1997	2003	7503-Z	D632		•	•		2182TT	S723						•
E-150 ECONOLINE	2004	2005	7948-Z	D1045		•	•		2182TT	S723						•
E-150 ECONOLINE	2004	2005	7948-Z	D1045		•	•		7949-Z	D1046		•	•			

MODELO Model	AÑO Inicio	AÑO Final	BALATAS DELANTERAS			AZUL	FIX	SFC	SHD	BALATAS TRASERAS			AZUL	FIX	SFC	SHD	FT OW
			Pastilla	Zapata	Características					Pastilla	Zapata	Características					
F-150	2004	2004	7576-Z	D702		•	•	•	7916-Z	D1012		•					
F-150	2004	2008	7915-Z1	D1083		•	•	•	7916-Z	D1012		•					
F-150	2008	2009	7915-Z2	D1392		•	•	•	7916-Z	D1012		•					
F-150	2010	2012	8528-Z	D1414		•	•	•	7916-Z	D1012		•					
F-150	2012	2017	8528-Z	D1414		•	•	•	8816-Z	D1602		•					
F-150	2015	2017	8528-Z	D1414		•	•	•	9018-Z	D1790	Con EPB			•			
F-200	1986	1991	7013-Z	D50		•			2080TT	S264						•	
F-250	1970	1975	771-Z	D20		•											
F-250	1973	1978	788-Z	D50		•											
F-250	1976	1994	7330-Z	D450		•		•									
F-250	1995	1997	7535-Z	D655		•		•	7584-Z1	D879		•		•			
F-250	1997	1999	7576-Z	D702		•	•	•	7584-Z1	D879		•		•			
F-250	1998	1998	7576-Z	D702		•	•	•	7584-Z	D711		•		•			
F-250 SUPER DUTY	1999	2004	7625-Z1	D824		•	•	•	7626-Z	D757		•		•			
F-250 SUPER DUTY	2005	2008	7974-Z	D1069		•	•	•	7973-Z1	D1068		•		•			
F-250 SUPER DUTY	2008	2008	7974-Z1	D1333		•		•	7973-Z1	D1068		•		•			
F-250 SUPER DUTY	2008	2008	7974-Z	D1069		•	•	•	7973-Z2	D1334		•		•			
F-250 SUPER DUTY	2008	2011	7974-Z1	D1333		•		•	7973-Z2	D1334		•		•			
F-250 SUPER DUTY	2011	2012	7974-Z1	D1333		•		•	8652-Z	D1334				•			
F-250 SUPER DUTY	2013	2017	8909-Z	D1680		•		•	8918-Z	D1691		•		•			
F-350	1971	1975	771-Z	D20		•											
F-350	1980	1994	7330-Z	D450		•		•	2137	S314						•	
F-350	1995	2000	7535-Z	D655		•		•	2137	S314						•	
F-350 SUPER DUTY	1999	2004	7625-Z1	D824		•	•	•	7626-Z	D757		•		•			
F-350 SUPER DUTY	2005	2007	7974-Z	D1069	DRW	•	•	•	7973-Z	D1067		•		•			
F-350 SUPER DUTY	2005	2007	7974-Z	D1069		•	•	•	7973-Z1	D1068		•		•			
F-350 SUPER DUTY	2005	2008	7974-Z	D1069	Ensamblada en Mé * ico	•	•	•	2171T	S583						•	
F-350 SUPER DUTY	2008	2012	7974-Z1	D1333		•		•	7973-Z2	D1334		•		•			
F-350 SUPER DUTY	2011	2012	7974-Z1	D1333		•	•	•	8652-Z	D1334				•			
F-350 SUPER DUTY	2013	2016	8909-Z	D1680		•		•	8918-Z	D1691		•		•			
F-450 SUPER DUTY	1988	1998	7299-Z	D411		•		•	7299-Z	D411		•		•			
F-450 SUPER DUTY	1999	2012	7644-Z	D777		•		•	7644-Z	D777		•		•			
F-450 SUPER DUTY	2009	2012	7974-Z1	D1333		•		•	7644-Z	D777		•		•			
F-450 SUPER DUTY	2011	2012	7974-Z1	D1333		•		•	8652-Z	D1334				•			
F-450 SUPER DUTY	2014	2015	7644-Z	D777	Cab & Chassis	•		•	7644-Z	D777		•		•			
F-450 SUPER DUTY	2013	2016	8909-Z	D1680		•		•	8918-Z	D1691		•		•			
F-450 SUPER DUTY	2017	2018	9249-Z	D2018		•		•	9249-Z	D2018		•		•			
F53	1988	1997	7299-Z	D411		•		•	7299-Z	D411		•		•			
F53	1999	2004	7644-Z	D777		•		•	7644-Z	D777		•		•			
F53	2008	2014	7644-Z	D777	16K - 22K GVW	•		•	7644-Z	D777		•		•			
F-550 SUPER DUTY	1999	2016	7644-Z	D777		•		•	7644-Z	D777		•		•			
F-550 SUPER DUTY	2017	2018	9249-Z	D2018		•		•	9249-Z	D2018		•		•			
F59	1988	1997	7299-Z	D411		•		•	7299-Z	D411		•		•			
FREESTAR	2004	2007	7927-Z	D1022		•	•	•	7926-Z	D1021		•		•			
FREESTYLE	2005	2007	7975-Z	D1070		•		•	7976-Z	D1071		•		•			
LOBO	1996	2002	7558-Z	D679		•	•	•	7584-Z1	D879		•		•			
LOBO	1997	2002	7576-Z	D702		•	•	•	7584-Z1	D879		•		•			
LOBO	2003	2008	7915-Z1	D1083		•		•	7916-Z	D1012		•		•			
LOBO	2004	2004	7576-Z	D702		•		•	7916-Z	D1012		•		•			
LOBO	2006	2007	7915-Z1	D1083	Harley Davidson	•		•	7916-Z	D1012		•		•			
LOBO	2006	2008	7974-Z	D1069	Harley Davidson	•	•	•	7973-Z	D1067		•		•			
LOBO	2009	2011	7915-Z2	D1392		•		•	7916-Z	D1012		•		•			
LOBO	2010	2017	8528-Z	D1414		•	•	•	7916-Z	D1012		•		•			
LOBO	2012	2017	8528-Z	D1414		•	•	•	8816-Z	D1602		•		•			
P350 MICROBUS	1986	1994	7330-Z	D450		•		•	2171T	S583						•	
P350 MICROBUS	1995	1997	7677-Z	D655		•		•	2171T	S583						•	
RANGER	1982	1983	7125-Z	D205		•	•										
RANGER	1983	1985	7125-Z1	D249		•		•									
RANGER	1986	1987	7224-Z	D326		•											
RANGER	1988	1994	7125-AZ	D387		•			2089AT	S581						•	
RANGER	1995	1998	7532-Z	D652		•	•	•	2180T	S704						•	
RANGER	1995	2002	7532-Z	D652		•	•	•	2089AT	S705						•	
RANGER	1998	2002	7532-Z	D652		•	•	•	7545-AZ	D667		•		•			
RANGER	2003	2012	7706-Z	D833		•	•	•	2180T	S704						•	
RANGER	2010	2010	7706-Z	D833		•		•	7835-Z	D932		•		•			
RANGER	2013	2017	8905-Z	D1676		•		•	1709	S1049						•	
RANGER	2010	2012	7532-Z	D652	Argentina	•	•	•	2210T	S1036						•	
TRANSIT	2007	2012	7Y43-Z	F317		•		•	7Y46-Z	F338				•			
TRANSIT	2008	2012	8736-Z	D1528		•		•	8701-Z	D1502		•		•			
TRANSIT	2010	2013	7871-Z	D970		•											

MODELO Model	AÑO Inicio	AÑO Final	BALATAS DELANTERAS			AZUL	FIX	SPC	SHD	BALATAS TRASERAS			AZUL	FIX	SPC	SHD	FT OW
			Pastilla	Zapata	Características					Pastilla	Zapata	Características					
TRANSIT	2013	2013	8767-Z	D1555													
TRANSIT	2014	2017	9014A-Z	D1787	Custom					9013-Z	D1786						
TRANSIT	2014	2017	9004-Z	D1774	150, 250, 350, 350HD					9005-Z	D1775						
WINDSTAR	1994	1994	7479-Z	D601						7543-Z	D664						
WINDSTAR	1994	2003	7479-Z	D601						1452	S665						
WINDSTAR	1995	1998	7536-Z	D656						7543-Z	D664						
WINDSTAR	1999	2003	7674-Z	D803						7543-Z	D664						
GMC																	
C4500 Topkick	2009	2009	7636-Z1	D1032													
C5500 Topkick	2009	2009	7636-Z1	D1032													
C6500 Topkick	2009	2009	7636-Z1	D1032													
C7500 Topkick	2009	2009	7636-Z1	D1032													
GMC TRUCK																	
ACADIA	2007	2017	8410-Z	D1169						7760-Z	D883						
C15	1970	1972								2006	S280						
C1500	1973	1976	728-AZ	D52						2006	S280						
C1500	1976	1978	728-AZ	D52						2159TT	S449						
C1500	1978	1987	728-AZ	D52						2073T	S473						
C1500	1980	1987	728-Z	D52						2073T	S473						
C1500	1988	1990	7259-Z	D368						1404A	S675						
C1500	1995	1995	7259-Z1	D369													
C2500	1971	1978	728-AZ	D52						2073T	S473						
C2500	1985	1985	7084-Z	D153						2042AT	S451						
C2500	1985	1985	728-AZ	D52						2042AT	S451						
C2500	1985	1985	728-Z	D52						2042AT	S451						
C2500	1985	1985	7084-Z	D153						2073T	S473						
C2500	1985	1985	728-AZ	D52						2073T	S473						
C2500	1985	1985	728-Z	D52						2073T	S473						
C2500	1987	1991	7260-Z	D370						2042AT	S451						
C2500	1987	1991	7260-Z	D370						2073T	S473						
C2500	1988	1991	7260A-Z	D370MA						2042AT	S451						
C2500	1988	1991	7260A-Z	D370MA						2073T	S473						
C3500	1976	1976	7081-Z	D149						2157T	S452						
C3500	1972	1978	728-AZ	D52						2042AT	S451						
C3500	1980	1989	7260A-Z	D370MA						2042AT	S451						
C3500	1977	1989	7260A-Z	D370MA						2157T	S452						
C3500	1980	1989	7260A-Z	D370MA						7081-Z	D149						
C3500	1980	1991	7260-Z	D370						2042AT	S451						
C3500	1980	1991	7260-Z	D370						2157T	S452						
C3500	1980	1991	7081-Z	D149						7081-Z	D149						
C3500	1980	1991	7260-Z	D370						7081-Z	D149						
C3500	1990	1991	7081-Z	D149						2042AT	S451						
C3500	1990	1991	7339-Z	D459						2042AT	S451						
C3500	1990	1991	7081-Z	D149						2157T	S452						
C3500	1990	1991	7339-Z	D459						2157T	S452						
C3500	1990	1991	7339-Z	D459						7081-Z	D149						
CABALLERO	1978	1982	7070-Z	D154													
CABALLERO	1983	1987	7070-AZ1	D154						2117ATT	S514						
CANYON	2004	2008	7943-Z	D1039						1548	S815						
CANYON	2009	2012	8282-Z	D1169						1643	S959						
ENVOY	2002	2005	7759-Z	D882						7760-Z	D883						
ENVOY	2006	2009	8282-Z	D1169						7760-Z	D883						
G1500	1972	1975	728-AZ	D52						2006	S280						
G1500	1976	1978	728-AZ	D52						2159TT	S449						
G1500	1978	1978	728-AZ	D52						2073T	S473						
G1500	1992	1993	728-AZ	D52													
G1500	1992	1993	728-Z	D52													
G2500	1971	1974	728-AZ	D52						2006	S280						
G2500	1984	1984	728-AZ	D52						2073T	S473						
G2500	1992	1993	728-AZ	D52													
G2500	1992	1993	728-Z	D52													
G3500	1972	1974	728-AZ	D52													
G3500	1979	1979	7081-Z	D149						2042AT	S451						
G3500	1979	1979	7084-Z	D153						2157T	S452						
G3500	1980	1984	728-AZ	D52						2157T	S452						
JIMMY	1990	1991	728-AZ	D52						2073T	S473						
JIMMY	1990	1991	728-Z	D52						2073T	S473						
JIMMY	1995	1997	7070-AZ1	D154						2117ATT	S514						

MODELO Model	AÑO Inicio	AÑO Final	BALATAS DELANTERAS			AZUL	FIX	SFC	SHD	BALATAS TRASERAS			AZUL	FIX	SFC	SHD	FT OW
			Pastilla	Zapata	Características					Pastilla	Zapata	Características					
JIMMY	1996	1997	7634-Z	D767		•			2117ATT	S514						•	
JIMMY	1997	1997	7593-Z	D726		•			2117ATT	S514						•	
JIMMY	1997	1997	7070-AZ1	D154		•	•	•	7596-Z	D729		•		•			
JIMMY	1997	1997	7634-Z	D767		•			7596-Z	D729		•		•			
JIMMY	1997	2005	7593-Z	D726		•	•		7596-Z	D729		•		•			
K1500	1971	1977	728-AZ	D52		•		•	2006	S280						•	
K1500	1978	1978	728-AZ	D52		•		•	2073T	S473						•	
K1500	1995	1995	7259-Z1	D369		•	•		1404A	S675						•	
K2500	1975	1978	728-AZ	D52		•		•	2073T	S473						•	
K3500	1977	1978							2157T	S452						•	
P1500	1971	1977	728-AZ	D52		•		•	2006	S280						•	
P1500	1972	1980	728-AZ	D52		•		•	2073T	S473						•	
P2500	1976	1986	728-AZ	D52		•		•	2042AT	S451						•	
P2500	1978	1978	728-AZ	D52		•		•	2073T	S473						•	
P3500	1973	1974	728-AZ	D52		•		•								•	
P3500	1989	1989	7081-Z	D149		•		•	2042AT	S451						•	
P3500	1989	1990	7084-Z	D153		•		•	2042AT	S451						•	
P3500	1989	1996	7081-Z	D149		•		•	7081-Z	D149		•				•	
S15	1982	1990	7070-AZ1	D154		•	•	•	2117ATT	S514						•	
S15	1982	1994	7070-AZ1	D154	Jimmy	•	•	•	2117ATT	S514						•	
SAFARI	1987	1989	728-AZ	D52		•		•	2134BT	S652						•	
SAFARI	1990	2002	7259-Z1	D369		•	•		2117ATT	S514						•	
SAFARI	2003	2005	7653-Z	D785		•	•	•	7700-Z	D792		•		•			
SAVANA 1500	1996	2002	7259-Z1	D369		•	•		7881-Z	D974		•		•			
SAVANA 1500	2000	2008	7653-Z	D785		•	•		7881-Z	D974		•		•			
SAVANA 1500	2009	2013	8472-Z	D1363		•	•	•	7881-Z	D974		•		•			
SAVANA 2500	1996	1999	7260A-Z	D370MA		•		•									
SAVANA 2500	1996	2002	7259-Z1	D369		•	•										
SAVANA 2500	1996	2002	7260-Z	D370		•		•									
SAVANA 2500	2001	2002	7339-Z	D459		•		•									
SAVANA 2500	2003	2005	7653-Z	D785		•	•	•	7875-Z	D974		•		•			
SAVANA 2500	2003	2015	8454-Z	D784		•		•	7875-Z	D974		•		•			
SAVANA 3500	1996	2002	7260-Z	D370		•		•									
SAVANA 3500	1996	2002	7339-Z	D459		•		•									
SAVANA 3500	2000	2002	7260A-Z	D370MA		•		•									
SAVANA 3500	2003	2009	7652-Z	D784		•	•	•	7891-Z	D989		•		•			
SAVANA 3500	2003	2013	7652-Z	D784		•	•	•	7875-Z	D974		•		•			
SAVANA 3500	2008	2013	7652-Z	D784		•	•	•	8523-Z	D1411				•			
SAVANA 3500	2013	2013	8454-Z	D784		•	•	•	7875-Z	D974		•		•			
SAVANA 4500	2009	2013	8454-Z	D784		•	•	•	8523-Z	D1411				•			
SIERRA	2001	2001	7653-Z	D785	C3	•	•	•	7700-Z	D792		•		•			
SIERRA	2002	2004	7653-Z	D785	Denali	•	•	•	7653-Z	D785		•		•			
SIERRA	2005	2007	7997-Z	D1092	Denali	•	•	•	7707-Z	D834		•		•			
SIERRA	2007	2007	7997-Z	D1092	Denali	•	•	•	8312-Z	D1194		•		•			
SIERRA	2008	2010	8472-Z	D1363	Denali	•	•	•	8312-Z	D1194		•		•			
SIERRA	2009	2013	8472-Z	D1363	4WD	•	•	•	8312-Z	D1194		•		•			
SIERRA 1500	1999	1999	7653-Z	D785		•	•	•	7662-Z	D792		•		•			
SIERRA 1500	2000	2000	7653-Z	D785		•	•	•	7653-Z	D785		•		•			
SIERRA 1500	2001	2006	7653-Z	D785		•	•	•	7700-Z	D792		•		•			
SIERRA 1500	2002	2002	7652-Z	D784		•	•	•	7700-Z	D792		•		•			
SIERRA 1500	2002	2002	7652-Z	D784		•	•	•	7707-Z	D834		•		•			
SIERRA 1500	2002	2004	7653-Z	D785		•	•	•	7707-Z	D834		•		•			
SIERRA 1500	2005	2006	7997-Z	D1092		•	•	•	7700-Z	D792		•		•			
SIERRA 1500	2005	2007	7997-Z	D1092		•	•	•	1583	S855						•	
SIERRA 1500	2007	2007	7997-Z	D1092		•	•	•	8312-Z	D1194		•		•			
SIERRA 1500	2008	2008	8472-Z	D1363		•	•	•	1583	S855						•	
SIERRA 1500	2008	2017	8472-Z	D1363		•	•	•	8312-Z	D1194		•		•			
SIERRA 1500 HD	2001	2007	7652-Z	D784		•	•	•	7653-Z	D785		•		•			
SIERRA 2500	1999	2004	7652-Z	D784		•	•	•	7653-Z	D785		•		•			
SIERRA 2500 HD	2001	2002	7653-Z	D785		•	•	•	7653-Z	D785		•		•			
SIERRA 2500 HD	2001	2010	7652-Z	D784		•	•	•	7653-Z	D785		•		•			
SIERRA 2500 HD	2011	2017	8523-Z	D1411		•		•	8523-Z	D1411				•			
SIERRA 3500	2001	2007	7652-Z	D784		•	•	•	7788-Z	D909		•		•			
SIERRA 3500	2004	2007	7652-Z	D784		•	•	•	7653-Z	D785		•		•			
SIERRA 3500 HD	2007	2010	8454-Z	D784		•	•	•	7653-Z	D785		•		•			
SIERRA 3500 HD	2007	2010	8454-Z	D784		•	•	•	7788-Z	D909		•		•			
SIERRA 3500 HD	2011	2015	8523-Z	D1411		•		•	8523-Z	D1411				•			
SONOMA	1991	2002	7070-AZ1	D154		•	•	•	2117ATT	S514						•	
SONOMA	1996	1997	7634-Z	D767		•			2117ATT	S514						•	
SONOMA	1998	2003	7070-AZ1	D154		•	•	•	7596-Z	D729		•		•			

MODELO Model	AÑO Inicio	AÑO Final	BALATAS DELANTERAS			AZUL	FIX	SPC	SHD	BALATAS TRASERAS			AZUL	FIX	SPC	SHD	FT OW
			Pastilla	Zapata	Características					Pastilla	Zapata	Características					
SONOMA	1998	2003	7593-Z	D726		•	•		2117ATT	S514						•	
SONOMA	1998	2004	7593-Z	D726		•	•		7596-Z	D729		•	•			•	
SUBURBAN 1500	1975	1978	728-AZ	D52		•		•	2042AT	S451						•	
SUBURBAN 1500	1992	1999	7260-Z	D370		•		•	2042AT	S451						•	
SUBURBAN 1500	1995	1999	7260A-Z	D370MA		•		•	2073T	S473						•	
SUBURBAN 2500	1990	1991	728-AZ	D52		•		•	2042AT	S451						•	
TERRAIN	2010	2017	8536-Z	D1421				•	8391-Z	D1275		•	•			•	
TERRAIN	2014	2015	8512-Z	D1404	Latinoamerica	•		•	8391-Z	D1275		•	•			•	
YUKON	1992	2000	7259-Z1	D369		•		•	1404A	S675						•	
YUKON	1997	1998	7260A-Z	D370MA		•		•	1404A	S675						•	
YUKON	1997	1998	7260-Z	D370		•		•	1404A	S675						•	
YUKON	2000	2000	7259-Z1	D369		•		•	7700-Z	D792		•	•			•	
YUKON	2000	2000	7653-Z	D785		•		•	7700-Z	D792		•	•			•	
YUKON	2000	2000	7259-Z1	D369		•		•	7707-Z	D834		•	•	•		•	
YUKON	2000	2002	7653-Z	D785	XL 1500	•		•	7700-Z	D792		•	•			•	
YUKON	2000	2006	7653-Z	D785		•		•	7707-Z	D834		•	•			•	
YUKON	2000	2008	7652-Z	D784	XL 2500	•		•	7653-Z	D785		•	•			•	
YUKON	2002	2006	7653-Z	D785		•		•	7881-Z	D974		•	•			•	
YUKON	2007	2007	7997-Z	D1092		•		•	8312-Z	D1194		•	•			•	
YUKON	2008	2017	8472-Z	D1363		•		•	8312-Z	D1194		•	•			•	
YUKON	2009	2016	8454-Z	D784	XL 2500	•		•	7653-Z	D785		•	•			•	

HONDA

ACCORD	1984	1985	7178-Z	D273		•			1364	S576						•
ACCORD	1988	1989							1364	S576						•
ACCORD	1986	1989	7229-Z	D334		•			1364	S576						•
ACCORD	1990	1993							1429	S627						•
ACCORD	1990	1993							7418-Z1	D537		•	•			•
ACCORD	1994	1997	7345-Z	D465		•		•	1429	S627						•
ACCORD	1991	1997	7382-Z	D503	Station Wagon	•		•	1429	S627						•
ACCORD	1995	1996	7382-Z	D503	Sedan	•		•	7418-Z	D536		•	•			•
ACCORD	1997	2001	7382-Z	D503	Sedan	•		•	7418-Z1	D537		•	•			•
ACCORD	2000	2001	7382-Z	D503	Coupe	•		•	7418-Z1	D537		•	•			•
ACCORD	1998	2002	7632-Z	D764	Sedan	•			1429	S627						•
ACCORD	1998	2002	7632-Z	D764	Coupe	•			1429	S627						•
ACCORD	1998	2002	7382-Z	D503	Coupe V6	•		•	1429	S627						•
ACCORD	1998	2002	7382-Z	D503	Coupe V6	•		•	7418-Z1	D537		•	•			•
ACCORD	1998	2002	7573-Z	D465	Motor 4 Cilindros	•		•	7418-Z1	D537		•	•			•
ACCORD	2003	2007	7795-Z	D914	Motor 4 Cilindros	•		•	7418-Z1	D537		•	•			•
ACCORD	2003	2007	7656-Z1	D1506	Motor 6 Cilindros	•		•	7418-Z1	D537		•	•			•
ACCORD	2008	2012	7656-Z1	D1506	Versión EX, Motor V6	•		•	8447-Z	D1336		•	•			•
ACCORD	2008	2012	7795-Z	D914	Versión LX, Motor L4	•		•	8447-Z	D1336		•	•			•
ACCORD	2013	2015	7795-Z	D914	Versión LX	•		•	8711-Z	D1451			•			•
ACCORD	2016	2018	8883-Z	D1654	Versión LX	•			8711-Z	D1451			•			•
ACCORD	2013	2017	8883-Z	D1654	Versión EX	•		•	8711-Z	D1451			•			•
ACCORD CROSSTOUR	2010	2011	7994-Z1	D1521		•		•	7418-Z3	D1086		•	•			•
CITY	2010	2013	782Y-Z	F369		•		•	7443-Z	D564		•	•			•
CITY	2014	2018	8502-Z	D1394		•		•	1618	S913						•
CIVIC	1988	1997	7178-Z	D273		•		•	7443-Z	D564		•	•			•
CIVIC	1992	2000	7178-Z	D273		•			1364	S576						•
CIVIC	1994	1995	7493-Z	D617		•		•	7443-Z	D564		•	•			•
CIVIC	1994	1997	7497-Z1	D948	Del Sol	•		•	7443-Z	D564		•	•			•
CIVIC	1994	1999	7493-Z	D617	Sedan / Coupe	•		•	1364	S576						•
CIVIC	1995	1997	7493-Z	D617	Del Sol	•		•	7443-Z	D564		•	•			•
CIVIC	1996	2005	7573-Z	D465	Sedan / Coupe	•		•	1364	S576						•
CIVIC	2001	2005	7573-Z	D465	Sedan	•		•	7443-Z	D564		•	•			•
CIVIC	2003	2005	7573-Z	D465		•		•	1429	S627						•
CIVIC	2006	2011	7573-Z	D465	Sedan / Coupe	•		•	7418-Z	D536		•	•			•
CIVIC	2006	2011	7702-Z	D829	SI	•		•	7418-Z1	D537		•	•			•
CIVIC	2006	2013	8392-Z	D1276	GX	•		•	1429	S627						•
CIVIC	2006	2014	7573-Z	D465	Sedan	•		•	1618	S913						•
CIVIC	2010	2010	7497-Z1	D948	SI, Hybrid	•		•	7418-Z1	D537		•	•			•
CIVIC	2008	2015	7497-Z1	D948	Hybrid	•		•	1429	S627						•
CIVIC	2012	2015	7795-Z	D914	SI, EX	•		•	7418-Z1	D537		•	•			•
CIVIC	2016	2018	7795-Z	D914		•		•								•
CRX	1990	1991	7178-Z	D273		•										•
CR-Z	2011	2015	8502-Z	D1394		•		•	7418-Z1	D537		•	•			•
CR-Z	2016	2016	7795-Z	D914		•		•	9069-Z	D1841			•			•
EV PLUS	1998	1998	7382-Z	D503		•		•	7418-Z	D536		•	•			•
FIT	2004	2008	8320-Z	D1200	07-08 Ensamblado en Brasil	•		•								•

MODELO Model	AÑO Inicio	AÑO Final	BALATAS DELANTERAS			AZUL	FIX	SFC	SHD	BALATAS TRASERAS			AZUL	FIX	SFC	SHD	FT OW
			Pastilla	Zapata	Características					Pastilla	Zapata	Características					
FIT	2007	2011	7497-Z1	D948		•	•		1364	S576						•	
FIT	2009	2013	7497-Z1	D948		•	•		1618	S913						•	
FIT	2009	2013	8502-Z	D1394		•	•		1618	S913						•	
FIT	2010	2011	782Y-Z	F369		•	•		1364	S576						•	
FIT	2010	2014	782Y-Z	F369		•	•		7443-Z	D564	Sistema de Frenos Akebono •		•			•	
FIT	2013	2014	7795-Z	D914	EV	•	•		1429	S627						•	
FIT	2015	2018	8502-Z	D1394	Cool, Fun, Hit	•	•		1618	S913						•	
INSIGHT	2010	2014	7573-Z	D465		•	•		1618	S913						•	
PRELUDE	1985	1987	7229-Z	D334		•											
PRELUDE	1988	1989	7229-Z	D334		•			7443-Z	D564		•	•				
PRELUDE	1992	2001	7382-Z	D503		•	•		7418-Z1	D537		•	•				
S2000	2000	2009	7702-Z	D829		•	•		7418-Z1	D537		•	•				

HONDA TRUCK

BR-V	2018	2019	8392-Z	D1276		•	•		1429	S627						•
HR-V	2016	2018	8883-Z	D1654		•	•		9069-Z	D1841			•			•
CR-V	1997	2001	7382-Z	D503		•	•		1429	S627						•
CR-V	2002	2006	7795-Z	D914		•	•		7418-Z	D536		•	•			•
CR-V	2007	2016	7795-Z	D914	FWD	•	•		7418-Z3	D1086		•	•			•
CR-V	2007	2016	7994-Z1	D1521	AWD	•	•		7418-Z3	D1086		•	•			•
ELEMENT	2003	2011	7795-Z	D914		•	•		7418-Z	D536		•	•			•
ODYSSEY	1995	1998	7382-Z	D503		•	•		7418-Z	D536		•	•			•
ODYSSEY	1999	2004	7663-Z	D793		•	•		7740-Z	D865		•	•			•
ODYSSEY	2005	2010	7994-Z1	D1521		•	•		7993-Z	D1088		•	•			•
ODYSSEY	2011	2017	7994-Z1	D1521		•	•		8397-Z	D1281		•	•			•
PASSPORT	1994	1995	7459-Z	D579		•			1360	S619						•
PASSPORT	1994	1995	7347-Z	D363		•			7460-Z	D580		•				•
PASSPORT	1994	1995	7459-Z	D579		•			7460-Z	D580		•				•
PASSPORT	1994	1996	7347-Z	D363		•			1360	S619						•
PASSPORT	1996	1996	7585-Z	D579		•			1360	S619						•
PASSPORT	1996	1996	7347-Z	D363		•										•
PASSPORT	1996	2000	7585-Z	D579		•										•
PASSPORT	2001	2001	7459-Z	D579		•			7460-Z	D580		•				•
PILOT	2003	2008	7795-Z	D914		•	•		7740-Z	D865		•	•			•
PILOT	2009	2016	8396-Z	D1280		•	•		8397-Z	D1281		•	•			•
RIDGELINE	2006	2014	8208-Z	D1102		•	•		8209-Z	D1103		•				•

HUMMER

H1	2004	2004	7531-Z	D651		•	•		7658-Z	D788						•
H2	2003	2009	7652-Z	D784		•	•		7653-Z	D785		•	•			•
H2	2006	2009	8225-Z	D1119		•	•		7653-Z	D785		•	•			•
H2	2006	2009	7652-Z	D784		•	•		8226-Z	D1120		•	•			•
H2	2006	2009	8225-Z	D1119		•	•		8226-Z	D1120		•	•			•
H2	2008	2009	8454-Z	D784		•	•		7653-Z	D785		•	•			•
H2	2008	2009	8454-Z	D784		•	•		8226-Z	D1120		•	•			•
H3, H3T	2006	2010	8225-Z	D1119		•	•		8226-Z	D1120		•	•			•

HYUNDAI

ACCENT	1995	2002	7376-Z	D497		•	•		1379	S707						•
ACCENT	2003	2005	7376-Z	D497		•	•		1495	S808						•
ACCENT	2003	2006	7376-Z	D497		•	•		1616	S910						•
ACCENT	2006	2006	7376-Z	D497		•	•		8267-Z	D1157		•	•			•
ACCENT	2018	2018	8X51-Z	F386		•	•		8428-Z5	D1812						•
ELANTRA	1992	1998	7329-Z1	D700		•										•
ELANTRA	1998	2001	7329-Z1	D700		•										•
ELANTRA	2002	2006							1495	S808						•
ELANTRA	2007	2010	7825-Z	D924			•									•
ELANTRA	2014	2018	8810-Z	D1595			•		8428-Z5	D1812		•				•
EXCEL	1986	1994	7376-Z	D497		•	•									•
GRAND i10	2015	2017	8X65-Z	F467	Hatch Back / Sedan	•	•		1616	S1021						•
SCOUPE	1991	1995	7376-Z	D497		•	•									•
SONATA	1999	2001	7329-Z1	D700		•										•
SONATA	2004	2010	7825-Z	D924			•									•
SONATA	2015	2018	8614-Z	D1295	Limited		•		8428-Z6	D1813		•				•
SONATA	2015	2018	8614-Z	D1295	Sport 2.0 Turbo		•		8267-Z	D1157		•				•
SONATA	2015	2018	9035-Z	D1826	Base		•		8267-Z	D1157	Manual Parking Brake	•				•
STELLAR	1987	1987	7293-Z	D404		•	•									•
TIBURON	1997	1999	7329-Z1	D700		•										•
TIBURON	2003	2008	7825-Z	D924			•									•

MODELO Model	AÑO Inicio	AÑO Final	BALATAS DELANTERAS			BALATAS TRASERAS				AZUL	FIX	SPC	SHD	FT OW
			Pastilla	Zapata	Características	Pastilla	Zapata	Características						
HYUNDAI TRUCK														
CRETA	2017	2018	9049-Z	D1815				•	2X90	FT118				•
IX35	2015	2015	8614-Z	D1295				•	8267-Z	D1157				•
SANTA FE	2017	2018	9049-Z	D1815				•	8575-Z	D1439				•
TUCSON	2005	2009	7825-Z	D924				•						•
TUCSON	2016	2016	8614-Z	D1295				•	8428-Z6	D1813				•
TUCSON	2017	2018	9075-Z	D1847				•	8428-Z6	D1813				•
INFINITI														
G20	1991	1994	7342-Z	D462				•	7533-Z	D540				•
G20	1995	1996	7342-Z	D462				•	7421-Z1	D595				•
G20	1999	1999	7832-Z	D815				•	7533-Z	D540				•
G20	2000	2001	7318-Z1	D653				•	7533-Z	D540				•
G20	2002	2002	7318-Z1	D653				•	7777-Z	D900				•
G25	2011	2012	8221-Z	D888				•	8501-Z	D1393				•
G35	2003	2005	7318-Z2	D815				•	7784-Z	D905				•
G35	2005	2007	8221-Z	D888				•	7784-Z	D905				•
G35	2007	2008	8221-Z	D888				•	8405-Z	D1288				•
G35	2007	2008						•	8405-Z	D1288				•
G37	2008	2013						•	8405-Z	D1288				•
G37	2009	2011	8221-Z	D888				•	8405-Z	D1288				•
G37	2011	2013	8221-Z	D888				•	8501-Z	D1393				•
I30	1996	1999	7318-Z1	D653				•	7533-Z	D540				•
I30	2000	2001	7318-Z2	D815				•	7533-Z	D540				•
I35	2002	2004	7318-Z2	D815				•	7777-Z	D900				•
M30	1990	1992	7171-Z	D266				•						•
M35	2006	2010	8221-Z	D888				•	8405-Z	D1288				•
M35H	2012	2012	8221-Z	D888				•	8501-Z	D1393				•
M35H	2013	2013	8221-Z	D888				•	7784-Z	D905				•
M37	2011	2013	8221-Z	D888				•	8501-Z	D1393				•
M45	2006	2009	8221-Z	D888				•	7784-Z	D905				•
M45	2010	2010	8221-Z	D888				•	8405-Z	D1288				•
M56	2011	2013	8221-Z	D888				•	8501-Z	D1393				•
Q45	1997	2000	7566-Z1	D855				•						•
Q45	2001	2001	7910-Z	D855				•						•
Q50	2014	2017	8906-Z1	D1736				•	8501-Z	D1393				•
Q70	2014	2017	8221-Z	D888				•	8501-Z	D1393				•
Q70L	2015	2017	8221-Z	D888				•	8501-Z	D1393				•
INFINITI TRUCK														
EX35	2008	2009	8221-Z	D888				•	8405-Z	D1288				•
EX35	2009	2013	8221-Z	D888				•	8501-Z	D1393				•
EX37	2013	2013	8221-Z	D888				•	8501-Z	D1393				•
FX35	2003	2006	7870-Z	D969				•	7784-Z	D905				•
FX35	2007	2008	8221-Z	D888				•	7784-Z	D905				•
FX35	2009	2009	8221-Z	D888				•	8405-Z	D1288				•
FX35	2010	2012	8221-Z	D888				•	8501-Z	D1393				•
FX37	2013	2013	8221-Z	D888				•	8501-Z	D1393				•
FX45	2003	2006	7870-Z	D969				•	7784-Z	D905				•
FX45	2006	2008	8221-Z	D888				•	7784-Z	D905				•
QX4	1997	2003	7566-Z1	D855				•	1433	S631				•
QX56	2004	2006	7918-Z	D1015				•	7945-Z	D1041				•
QX56	2007	2010	8403-Z	D1286				•	7945-Z	D1041				•
QX56	2011	2013	8403-Z1	D1509				•						•
QX60	2014	2018	8877-Z	D1649				•	8405-Z	D1288				•
QX70	2014	2018	8221-Z	D888	3.7 L			•	8501-Z	D1393				•
QX80	2014	2018	8403-Z1	D1509				•						•
ISUZU TRUCK														
AMIGO	1989	1993	7347-Z	D363				•	1360	S619				•
AMIGO	1989	1993	7347-Z	D363				•	7328-Z1	D398				•
AMIGO	1994	1994	7459-Z	D579				•	1360	S619				•
AMIGO	1994	1994	7459-Z	D579				•	7460-Z	D580				•
AMIGO	1998	1999	7585-Z	D579				•						•
AMIGO	2000	2000	7459-Z	D579				•	7460-Z	D580				•
ASCENDER	2003	2005	7759-Z	D882				•	7760-Z	D883				•
ASCENDER	2006	2008	8282-Z	D1169				•	7760-Z	D883				•
AXIOM	2002	2002	7459-Z	D579				•	7460-Z	D580				•
ELF 200	2009	2013	8924-Z	D1700				•	1714	S1057				•

MODELO Model	AÑO Inicio	AÑO Final	BALATAS DELANTERAS			AZUL	FIX	SFC	SHD	BALATAS TRASERAS			AZUL	FIX	SFC	SHD	FT OW
			Pastilla	Zapata	Características					Pastilla	Zapata	Características					
ELF 300	2008	2014	7697-Z	D825		•		•									
ELF 400	2007	2014	7697-Z	D825		•		•	1482	S699							•
HOMBRE	1998	2000	7593-Z	D726		•	•		7596-Z	D729		•		•			•
I-280	2006	2006	7943-Z	D1039		•		•	1548	S815							•
I-290	2007	2008	7943-Z	D1039		•		•	1548	S815							•
I-350	2006	2006	7943-Z	D1039		•		•	1548	S815							•
I-370	2007	2008	7943-Z	D1039		•		•	1548	S815							•
OASIS	1996	1999	7382-Z	D503		•	•		7418-Z	D536		•		•			•
PICKUP	1980	1983							1358	S505							•
PICKUP	1984	1987	7188-Z	D285		•											•
PICKUP	1988	1995	7347-Z	D363		•			1360	S619							•
PICKUP	1990	1991	7347-Z	D363		•											•
PICKUP	1990	1993	7127-Z	D207		•		•									•
PICKUP	1990	1995	7127-Z	D207		•			1358	S505							•
PICKUP	1990	1995	7347-Z	D363		•			7328-Z1	D398		•					•
PICKUP	1992	1995	7127-Z	D207		•		•	1397	S589							•
RODEO	1991	1995	7347-Z	D363		•			1360	S619							•
RODEO	1994	1995	7459-Z	D579		•			1360	S619							•
RODEO	1994	1995	7347-Z	D363		•			7460-Z	D580		•					•
RODEO	1994	1995	7459-Z	D579		•			7460-Z	D580		•					•
RODEO	1996	1998	7585-Z	D579		•			1360	S619							•
RODEO	1996	1999	7585-Z	D579		•											•
RODEO	2000	2001	7459-Z	D579		•			7460-Z	D580		•					•
RODEO	2001	2001	7459-Z	D579	Sport	•			7460-Z	D580		•					•
SERIE N	2007	2011							1482	S699							•
TROOPER	1985	1987	7188-Z	D285		•											•
TROOPER	1987	1988	7253-Z	D363		•											•
TROOPER	1989	1991	7347-Z	D363		•			7328-Z1	D398		•					•
TROOPER	1990	1991	7347-Z	D363		•											•
TROOPER	1992	2002	7459-Z	D579		•			7460-Z	D580		•					•
VEHICROSS	1999	2001	7459-Z	D579		•			7460-Z	D580		•					•

JAGUAR

F-TYPE	2014	2014	8357-Z	D1305	3.0L Black Caliper			•									
F-TYPE	2015	2017	8357-Z	D1305				•									
S-TYPE	2000	2002	7676-Z	D805		•		•	7477-Z	D599		•		•			
S-TYPE	2004	2004	7676-Z	D805		•		•									
VANDEN PLAS	1993	1993							7563-Z	D688		•		•			
XF	2013	2014	8357-Z	D1305	3.0L / RWD			•	7957-Z1	D1095		•		•			
XJ	2014	2016	8357-Z	D1305	RWD			•	7957-Z1	D1095		•		•			
XJ12	1995	1996							7563-Z	D688		•		•			
XJ6	1995	1997							7563-Z	D688		•		•			
XJ8	1998	2005							7563-Z	D688		•		•			
XJ8	2006	2009							7957-Z1	D1095		•		•			
XJR	1995	2000							7563-Z	D688		•		•			
XK	2013	2016	8357-Z	D1305				•	7957-Z1	D1095		•		•			
XK8	1997	2000							7563-Z	D688		•		•			
XKR	2000	2000							7563-Z	D688		•		•			
X-TYPE	2002	2005	7789-Z	D910		•		•	7790-Z	D911		•		•			
X-TYPE	2005	2008	7789-Z	D910		•		•	7976-Z	D1071		•		•			

JEEP

CHEROKEE	1974	1983	728-AZ	D52		•		•									
CHEROKEE	1994	1996	7507-AZ	D477		•		•									
CHEROKEE	1994	2001	7507-AZ	D477		•		•	2174TT	S670							•
CHEROKEE	2014	2017	8932-Z	D1709	BRG	•		•	8958-Z	D1734				•			
CHEROKEE	2014	2017	8867-Z	D1640	BRF	•		•	8958-Z	D1734				•			
CJ5D	1980	1981	7027-Z	D91		•											
CJ5D	1980	1986	728-AZ	D52		•		•									
CJ5D	1980	1986	728-Z	D52		•											
CJ7	1982	1986	7122-Z	D203		•											
CJ7	1985	1986							2168T	S538							•
COMANCHE	1986	1992							2168T	S538							•
COMMANDER	2006	2010	7985-Z	D1080		•		•	7945-Z	D1041		•		•			
COMPASS	2007	2008	8338-Z	D866		•		•	7743-Z	D868		•		•			
COMPASS	2007	2008	8338-Z	D866		•		•	7940-Z	D1037		•		•			
COMPASS	2009	2017	7741-Z	D866	Freno de tambor	•		•	1462	S919		•		•			•
COMPASS	2009	2017	7741-Z	D866	Freno de emergencia al caliper	•		•	7743-Z	D868		•		•			
COMPASS	2009	2017	7741-Z	D866	Freno de emergencia con tambor	•		•	7940-Z	D1037		•		•			
GRAND CHEROKEE	1992	1992	7507-AZ	D477		•			2174TT	S670							•

MODELO Model	AÑO Inicio	AÑO Final	BALATAS DELANTERAS			AZUL	FIX	SFC	SHD	BALATAS TRASERAS			AZUL	FIX	SFC	SHD	FT OW
			Pastilla	Zapata	Características					Pastilla	Zapata	Características					
ES300H	2013	2017	8331-Z2	D1293						8332-Z	D1212						
ES350	2013	2017	8331-Z2	D1293						8332-Z	D1212						
IS250	2013	2016	7787-Z	D908													
IS250	2014	2016	7787-Z	D908	C												
LS400	1990	1992	7357-Z1	D718													
LS400	1990	1992	7357-Z	D476													
SC300	1992	1998	7357-Z1	D718													
SC300	1992	1998	7357-Z	D476													

LEXUS TRUCK

GX460	2013	2017	7877-Z	D976						7487-Z	D606						
LX450	1996	1997								7487-Z	D606						
LX470	1998	2000	7639-Z	D772													
LX570	2013	2016	8419-Z	D1303						8420-Z	D1304						
RX350	2013	2016	8436-Z	D1324						8500-Z	D1391						
RX450H	2013	2016	8436-Z	D1324						8500-Z	D1391						

LINCOLN

CONTINENTAL	1980	1980	7082-AZ	D150													
CONTINENTAL	1990	1992	7308-AZ	D421 MA													
CONTINENTAL	1990	1992	7308-AZ	D421 MA													
CONTINENTAL	1993	1994	7479-Z	D601						7489-Z	D610						
CONTINENTAL	1995	2002	7476-Z	D598						7489-Z	D610						
LS	2003	2003	7676-Z	D805													
LS	2004	2006	7676-Z	D805						7477-Z	D599						
MARK VI	1980	1981	7082-AZ	D150													
MARK VI	1982	1983	7082-Z	D199													
MARK VIII	1993	1998	7476-Z	D598						7477-Z	D599						
MKS	2009	2012								8488-Z	D1377						
MKS	2013	2017	8881-Z	D1611						8825-Z	D1612						
MKZ	2007	2012	8277-Z	D1164						8272-Z	D1161						
MKZ	2013	2017	8882-Z	D1653						8893-Z	D1665						
TOWN CAR	1981	1981	7082-AZ	D150													
TOWN CAR	1982	1994	7082-Z	D199													
TOWN CAR	1995	1995	7537-Z1	D678													
TOWN CAR	1996	1997	7537-Z1	D678						7610-Z	D674						
TOWN CAR	1998	2002	7617-Z	D748						7610-Z	D674						
TOWN CAR	2001	2002	7617-Z	D748						2182T	S734						
TOWN CAR	2003	2011	7834-Z	D931						7584-Z1	D879						
TOWN CAR	2003	2011	7834-Z	D931						7835-Z	D932						
ZEPHYR	2006	2006	8277-Z	D1164						8272-Z	D1161						

LINCOLN TRUCK

AVIATOR	2003	2005	7852-Z	D953													
BLACKWOOD	2002	2003	7558-Z	D679						7584-Z1	D879						
MARK LT	2006	2008	7915-Z1	D1083						7916-Z	D1012						
MARK LT	2010	2014	8528-Z	D1414													
MKT	2010	2011								8488-Z	D1377						
MKT	2012	2016	8715-Z	D1508						8488-Z	D1377						
MKT	2013	2014	8881-Z	D1611						8825-Z	D1612						
MKX	2007	2010	8377-Z	D1258						8807-Z	D1259						
MKX	2011	2015	8377-Z	D1258						8488-Z	D1377						
NAVIGATOR	1998	1999	7576-Z	D702						7584-Z	D711						
NAVIGATOR	2000	2002	7576-Z	D702						7584-Z1	D879						
NAVIGATOR	2003	2006	7837-Z	D934						7838-Z	D935						
NAVIGATOR	2007	2010	8394-Z	D1278						8395-Z	D1279						
NAVIGATOR	2011	2017	8528-Z	D1414						8395-Z	D1279						

MAZDA

2	2011	2015	8738-Z	D1454						1437	S991						
2	2016	2018	9081-Z	D1852						1437	S991						
3	2004	2006	7947-Z	D1044	Motor 2.0L					7874-Z	D973						
3	2004	2006	7947-Z	D1044	Motor 2.3L					7957-Z1	D1095						
3	2007	2013	8220-Z	D915	Mazda Speed					7957-Z1	D1095						
3	2007	2013	7947-Z	D1044						7957-Z1	D1095						
3	2014	2018	8987-Z	D1759	Ensamblado en México					8908-Z	D1679						
3	2015	2018	8952-Z	D1728	Ensamblado en Japón												
5	2006	2006	7947-Z	D1044						7874-Z	D973						
5	2007	2014	7947-Z	D1044						7957-Z1	D1095						
6	2003	2005	7856-Z	D957						7186-Z1	D332						

MODELO Model	AÑO Inicio	AÑO Final	BALATAS DELANTERAS			BALATAS TRASERAS				AZUL	FIX	SFC	SHD	FT OW
			Pastilla	Zapata	Características	Pastilla	Zapata	Características						
C200K	2001	2003						7748-Z	D873					
C230	1999	2000						7647-Z	D779					
C230	2002	2005	7747-Z	D872				7647-Z	D779					
C230	2003	2004	7723-Z	D847				7647-Z	D779					
C230	2003	2004	7723-Z	D847				7748-Z	D873					
C230	2003	2006	7747-Z	D872				7748-Z	D873					
C230	2013	2013	7747-Z	D872										
C240	2001	2005	7747-Z	D872				7647-Z	D779					
C240	2003	2005	7747-Z	D872				7748-Z	D873					
C250	2010	2015	8451-Z	D1340				8452-Z	D1341					
C250	2012	2015	8453-Z	D1342	Performance			8452-Z	D1341					
C280	1998	1998						7647-Z	D779					
C280	2006	2009	7747-Z	D872				7748-Z	D873					
C300	2008	2012	8451-Z	D1340				8452-Z	D1341					
C300	2013	2014	8453-Z	D1342				8452-Z	D1341					
C32 AMG	2002	2004	7723-Z	D847										
C320	2001	2005	7747-Z	D872				7748-Z	D873					
C350	2006	2007	7723-Z	D847				7748-Z	D873					
C350	2006	2007	7747-Z	D872				7748-Z	D873					
C350	2008	2015	8453-Z	D1342				8452-Z	D1341					
C55 AMG	2005	2007	7723-Z	D847										
CL200K	2003	2003	7747-Z	D872				7748-Z	D873					
CL230K	2003	2003	7747-Z	D872				7647-Z	D779					
CL230K	2003	2003	7747-Z	D872				7748-Z	D873					
CL500	2000	2006	7723-Z	D847				7888-Z	D986					
CL500	2008	2012	7723-Z	D847										
CL55 AMG	2001	2002	7723-Z	D847										
CL600	2001	2006	7723-Z	D847										
CL600	2002	2003	7723-Z	D847										
CLK280	2007	2009	7747-Z	D872				7647-Z	D779					
CLK280	2007	2009	7747-Z	D872				7748-Z	D873					
CLK320	1998	1999	7730-Z	D853										
CLK320	2000	2003	7730-Z	D853				7748-Z	D873					
CLK320	2003	2005	7747-Z	D872				7748-Z	D873					
CLK350	2006	2009	7747-Z	D872				7748-Z	D873					
CLK430	1999	1999	7730-Z	D853										
CLK430	2000	2003	7730-Z	D853				7748-Z	D873					
CLK500	2003	2006	7723-Z	D847										
CLK55 AMG	2003	2004	7723-Z	D847										
CLK550	2007	2009	7723-Z	D847										
CLK63 AMG	2009	2009	7723-Z	D847										
CLS400	2015	2016	8453-Z	D1342										
CLS500	2006	2011	7723-Z	D847				7888-Z	D986					
E250	2014	2016	8453-Z	D1342										
E300	2013	2013	8453-Z	D1342										
E320	1994	1995	7538-Z	D561										
E320	1995	1995	7538-Z	D561										
E320	1998	2005	7730-Z	D853										
E320	1999	2005	7730-Z	D853										
E320	2003	2005	7730-Z	D853				7888-Z	D986					
E350	2010	2014	8453-Z	D1342	4Matic									
E350	2010	2014	8453-Z	D1342	Coupe			8452-Z	D1341					
E350	2015	2016	8453-Z	D1342										
E400	2013	2017						8452-Z	D1341					
E400	2013	2016	8453-Z	D1342	Sedán									
E420	1994	1995	7538-Z	D561										
E430	1998	1999	7730-Z	D853										
E430	1998	2002	7730-Z	D853										
E500	2003	2011	7723-Z	D847				7888-Z	D986					
E550	2007	2009	7723-Z	D847				7888-Z	D986					
E550	2010	2017	8453-Z	D1342				8452-Z	D1341					
GLK250	2013	2015						8452-Z	D1341					
GLK350	2010	2015						8452-Z	D1341					
ML320	1998	1999	7628-Z	D760										
ML320	1998	2003	7628-Z	D760										
ML350	2003	2005	7628-Z	D760										
ML430	1999	1999	7628-Z	D760										
ML430	2000	2001	7723-Z	D847										
ML500	2002	2005	7723-Z	D847										
ML55 AMG	2000	2003	7723-Z	D847										

MODELO Model	AÑO Inicio	AÑO Final	BALATAS DELANTERAS			AZUL	FIX	SPC	SHD	BALATAS TRASERAS			AZUL	FIX	SPC	SHD	FT OW
			Pastilla	Zapata	Características					Pastilla	Zapata	Características					
S430	1998	2000	7723-Z	D847													
S500	2000	2002	7723-Z	D847													
S500	2003	2006	7723-Z	D847					7888-Z	D986							
S600	2001	2006	7723-Z	D847													
SL500	1999	2000	7723-Z	D847													
SL500	2008	2013	7723-Z	D847					7888-Z	D986							
SL600	2000	2000	7723-Z	D847													
SLC300	2017	2018	8453-Z	D1342													
SLK	1996	1997							7647-Z	D779							
SLK200	2003	2005							7647-Z	D779							
SLK200	2006	2012	7747-Z	D872					7647-Z	D779							
SLK230	1998	2004							7647-Z	D779							
SLK250	2012	2015	8453-Z	D1342													
SLK280	2006	2008	7747-Z	D872					7647-Z	D779							
SLK350	2012	2016	8453-Z	D1342													
SLK55 AMG	2005	2011	7723-Z	D847													
SLK55 AMG	2007	2011	7723-Z	D847													

MERCEDES BENZ TRUCK

SPRINTER	2002	2005	7848-Z	D949	Box Van												
SPRINTER	2002	2005	7849-Z	D950	Box Van												
SPRINTER	2002	2006			Cargo Van 416 CDI				79W4A-Z	F315							
SPRINTER	2007	2014	79W3A-Z	F314	Cargo Van 415 CDI				79W4A-Z	F315							
SPRINTER	2007	2014	79W3A-Z	F314	Cargo Van 515 CDI				79W4A-Z	F315							
SPRINTER	2007	2014	8430A-Z	D1316	Cargo Van 315 CDI				8431A-Z	D1317							
SPRINTER 2500	2007	2015	8430A-Z	D1316					8431A-Z	D1317							
SPRINTER 315	2007	2014	8430A-Z	D1316					8431A-Z	D1317							
SPRINTER 316	2007	2014	8430A-Z	D1316					8431A-Z	D1317							
SPRINTER 3500	2007	2014	8430A-Z	D1316													
SPRINTER 415	2007	2014	79W3A-Z	F314					79W4A-Z	F315							
SPRINTER 415	2007	2014	8383-Z	D1268					8432-Z	D1318							
SPRINTER 416	2007	2014	79W3A-Z	F314					79W4A-Z	F315							
SPRINTER 416	2007	2014	8383-Z	D1268					8432-Z	D1318							
SPRINTER 515	2007	2014	79W3A-Z	F314					79W4A-Z	F315							
VITO	2009	2012	8430A-Z	D1316													

MERCURY

CAPRI	1979	1979	7072-AZ1	D152													
CAPRI	1983	1983	7072-AZ1	D152													
CAPRI	1991	1994	7219-Z	D319													
COLONY PARK	1987	1991	7082-AZ	D150													
MARAUDER	2003	2004	7834-Z	D931					7835-Z	D932							
MARQUIS	1973	1974	7013-Z	D50					2080TT	S264							
MARQUIS	1973	1974	788-Z	D50					2080TT	S264							
MARQUIS	1980	1984	7082-Z	D199													
MARQUIS	1985	1986	7072-BZ	D310													
MARQUIS	1985	1986	7072-Z	D181													
MILAN	2006	2011	8277-Z	D1164					8272-Z	D1161							
MONARCH	1976	1980	7027-Z	D91													
MONTEGO	1971	1971	776-AZ	D34													
MONTEGO	1972	1976	788-Z	D50													
MONTEGO	2005	2007	7975-Z	D1070					7976-Z	D1071							
MONTEREY	2004	2007	7927-Z	D1022					7926-Z	D1021							
SABLE	1986	1987	7222-Z	D324													
SABLE	1990	1992	7308-AZ	D421MA													
SABLE	1993	1993	7308-AZ	D421MA					7489-Z	D610							
SABLE	1993	1993							7489-Z	D610							
SABLE	1994	2000	7479-Z	D601					7489-Z	D610							
SABLE	2000	2000	7479-Z	D601					1396	S618							
SABLE	2001	2003	7476-Z	D598					1396	S618							
SABLE	2001	2005	7476-Z	D598					7489-Z	D610							
SABLE	2008	2009	7975-Z	D1070					7976-Z	D1071							
TRACER	1988	1989	7219-Z	D319													
TRACER	1990	1990	7219-Z1	D466					7514-Z1	D663							
TRACER	1990	1990	7353-Z	D473					7514-Z1	D663							
TRACER	1991	1992	7219-Z1	D466					7338-Z	D458							
TRACER	1991	1996	7353-Z	D473					7338-Z	D458							
TRACER	1997	1999	7353-Z	D473					1407	S721							
TRACER	1997	1999	7353-Z	D473					7514-Z1	D663							

MODELO Model	AÑO Inicio	AÑO Final	BALATAS DELANTERAS			AZUL	FIX	SFC	SHD	BALATAS TRASERAS			AZUL	FIX	SFC	SHD	FT OW
			Pastilla	Zapata	Características					Pastilla	Zapata	Características					

MERCURY TRUCK

MARINER	2005	2007	7719-Z	D843		•	•	1524	S760							•
MARINER	2005	2007	7950-Z	D1047		•	•	1524	S760							•
MARINER	2005	2007	7719-Z	D843		•	•	7961-Z	D1055		•	•				•
MARINER	2005	2007	7950-Z	D1047		•	•	7961-Z	D1055		•	•				•
MARINER	2007	2007	7719-Z	D843		•	•	1629	S936							•
MARINER	2007	2011	7950-Z	D1047		•	•	1629	S936							•
MARINER	2008	2009	8445-Z	D1047				7961-Z	D1055		•	•				•
MARINER	2009	2011	8445-Z	D1047				1629	S936							•
MOUNTAINEER	1997	2001	7532-Z	D652		•	•	7545-AZ	D667		•	•	•			•
MOUNTAINEER	2000	2001	7532-Z	D652		•	•	7758-Z	D881		•	•	•			•
MOUNTAINEER	2002	2004	7706-Z	D833		•	•	7907-Z	D881		•	•	•			•
MOUNTAINEER	2005	2005	7706-Z	D833		•	•	8214-Z	D1109		•	•	•			•
MOUNTAINEER	2006	2010	8268-Z	D1158		•	•	8214-Z	D1109		•	•	•			•
VILLAGER	1993	2002	7456-Z	D576		•	•	1452	S665							•

MINI

COOPER	2002	2008	7841-Z	D939		•	•	7842-Z1	D1060			•				•
COOPER	2002	2008	8324-Z	D1204				7842-Z1	D1060			•				•
COOPER	2007	2008	7841-Z	D939		•	•	8424-Z	D1309			•				•
COOPER	2007	2015	8324-Z	D1204	S			8424-Z	D1309			•				•
COOPER	2007	2015	8423-Z	D1308				8424-Z	D1309			•				•
COOPER	2016	2016	8324-Z	D1204	Countryman, Paceman											•

MITSUBISHI

3000GT	1991	1993						7272-Z	D383		•	•				•
3000GT	1991	1993	7412-Z	D530		•	•	7414-Z	D532		•					•
3000GT	1991	1993						7414-Z	D532		•					•
3000GT	1991	1999	7412-Z	D530		•	•	7272-Z	D383		•	•				•
DIAMANTE	1992	1996	7412-Z	D530		•	•	7272-Z	D383		•	•				•
DIAMANTE	1999	2004	7412-Z	D530		•	•									•
ECLIPSE	1990	1994	7365-Z	D484		•	•									•
ECLIPSE	1995	1999	7365-Z	D484		•	•	7272-Z	D383		•	•				•
ECLIPSE	2000	2012	7741-Z	D866		•	•	7272-Z	D383		•	•				•
ECLIPSE	2006	2012	7741-Z	D866		•	•	7414-Z	D532		•					•
GALANT	1990	1992	7365-Z	D484		•	•									•
GALANT	1990	2001	7365-Z	D484		•	•	7272-Z	D383		•	•				•
GALANT	1991	1992	7412-Z	D530		•	•									•
GALANT	1994	2001	7365-Z	D484		•	•	7272-Z	D383		•	•				•
GALANT	1999	2000	7412-Z	D530		•	•	7272-Z	D383		•	•				•
GALANT	2001	2012	7741-Z	D866		•	•	7272-Z	D383		•	•				•
GALANT	2007	2009	7741-Z	D866		•	•	7414-Z	D532		•					•
LANCER	2002	2006	7782-Z	D904		•	•									•
LANCER	2004	2016	7741-Z	D866	SE	•	•	7940-Z	D1037		•	•				•
LANCER	2008	2016	7741-Z	D866	ES, DE	•	•	1624	S924							•
LANCER	2008	2016	7741-Z	D866	GTS	•	•	7743-Z	D868		•	•				•
LANCER	2008	2014	7902-Z	D1001	Evolution			8477-Z	D1368			•				•
LANCER	2014	2014	7412-Z	D530	Ralliart	•	•	7743-Z	D868		•	•				•
MIRAGE	1991	1992	7365-Z	D484		•	•									•
MIRAGE	2015	2018	8956-Z	D1731		•	•	1717	S1059							•
PRECIS	1987	1987	795-Z1	D161		•										•
PRECIS	1988	1994	7376-Z	D497		•	•									•
RAIDER	2006	2009	7991-Z	D1084		•	•	1582	S922							•

MITSUBISHI TRUCK

ASX	2014	2015	7741-Z	D866		•	•	8908-Z	D1679			•				•
ENDEAVOR	2004	2011	7742-Z	D867		•	•	7743-Z	D868			•	•			•
EXPO	1992	1995	7365-Z	D484		•	•	7272-Z	D383		•	•				•
EXPO LRV	1992	1994	7365-Z	D484		•	•	7272-Z	D383		•	•				•
GRANDIS	2007	2009	7742-Z	D867		•	•	7743-Z	D868		•	•				•
L200	2008	2008	8334-Z	D1214		•	•									•
L200	2009	2011	8334-Z	D1214		•	•	1685	S1016							•
L200	2009	2017	8728-Z	D1519		•	•	1685	S1016							•
MIGHTY MAX	1985	1986						1370	S524							•
MIGHTY MAX	1987	1996	7241-Z	D349		•	•	1370	S524							•
MONTERO	1985	1987						1370	S524							•
MONTERO	1988	1991	7241-Z	D349				1370	S524							•
MONTERO	1992	2000	7412-Z	D530		•	•									•
MONTERO	1997	2004	7412-Z	D530	Sport	•	•									•

MODELO Model	AÑO Inicio	AÑO Final	BALATAS DELANTERAS							BALATAS TRASERAS							FT OW
			Pastilla	Zapata	Características	AZUL	FIX	SPC	SHD	Pastilla	Zapata	Características	AZUL	FIX	SPC	SHD	
MONTERO	2001	2008	7742-Z	D867		•	•		7743-Z	D868		•	•				
MONTERO	2009	2012	8728-Z	D1519	Sport	•	•	•	7743-Z	D868		•	•				
OUTLANDER	2003	2004	7741-Z	D866		•	•	•									
OUTLANDER	2007	2011	7741-Z	D866	Sport	•	•	•	7743-Z	D868		•	•				
OUTLANDER	2012	2016	7741-Z	D866		•	•	•	8908-Z	D1679			•				
VAN	1987	1990	7241-Z	D349		•	•	•	1370	S524						•	
NISSAN																	
210	1979	1982	7046-Z	D113		•	•										
310	1979	1982	7059-Z	D41		•	•										
510	1970	1973	780-Z	D37		•	•										
510	1978	1981	7046-Z1	D146		•	•										
610	1973	1974	780-Z	D37		•	•										
610	1975	1976	7046-Z	D113		•	•										
620	1975	1979	795-Z1	D161		•	•		8123	S406						•	
710	1974	1977	7046-Z	D113		•	•										
810	1977	1980	795-Z1	D161		•	•										
200SX	1977	1979	7046-Z	D113		•	•										
200SX	1980	1980	7046-Z	D113		•	•										
200SX	1995	1998	7546-Z	D668		•	•		1438	S638						•	
200SX	1995	1998	7546-Z	D668		•	•		7547-Z	D669		•	•				
240SX	1989	1998	7342-Z	D462		•	•										
240Z	1970	1973	794-Z	D57		•	•										
260Z	1974	1975	794-Z	D57		•	•										
280Z	1975	1978	794-Z	D57		•	•										
300ZX	1984	1989	7171-Z	D266		•	•										
300ZX	1989	1989	7171-Z	D266		•	•										
350Z	2003	2005	7318-Z2	D815		•	•		7784-Z	D905		•	•				
350Z	2006	2009	8221-Z	D888		•	•		7784-Z	D905		•	•				
370Z	2009	2009	8221-Z	D888		•	•		8405-Z	D1288		•	•				
370Z	2010	2017	8221-Z	D888		•	•		8501-Z	D1393		•	•				
ALMERA	2001	2005	8257-Z	D1147		•	•		8305-Z	D1187		•	•				
ALTIMA	1993	1995	7318-Z1	D653		•	•		7533-Z	D540		•	•				
ALTIMA	1996	1997	7318-Z	D430		•	•		7421-Z1	D595		•	•				
ALTIMA	1998	2001	7318-Z	D430		•	•		7533-Z	D540		•	•				
ALTIMA	2002	2006	7870-Z	D969	SE-R	•	•		7784-Z	D905		•	•				
ALTIMA	2002	2006	7783-AZ	D815	Sedan	•	•		7784-Z	D905		•	•				
ALTIMA	2008	2012	7318-Z2	D815	Sedan	•	•		8405-Z	D1288		•	•				
ALTIMA	2008	2012	7318-Z2	D815	Coupe	•	•		8501-Z	D1393		•	•				
ALTIMA	2013	2018	8878-Z	D1650		•	•		8501-Z	D1393		•	•				
APRIO	2008	2010	8256-Z	D1146		•	•		14Y8	FT032						•	
APRIO	2008	2010	71X4-Z	F051		•	•		14Y8	FT032						•	
APRIO	2008	2010	71X4-Z	F051		•	•		1Y20	FT031						•	
B210	1976	1978	7046-Z	D113		•	•										
F10	1976	1978	7059-Z	D41		•	•										
HIKARI	1987	1992	7155-Z	D233		•	•										
LEAF	2014	2017	8878-Z	D1650		•	•		8501-Z	D1393		•	•				
LUCINO	1995	2000	7428-Z	D549		•	•		7547-Z	D669		•	•				
MARCH	2011	2018	8804-Z	D1592		•	•		1689	S1020						•	
MAXIMA	1985	1988	7171-Z	D266		•	•										
MAXIMA	1988	1988	7170-Z	D265		•	•										
MAXIMA	1991	1994	7318-Z1	D653		•	•		1381	S607						•	
MAXIMA	1991	1999	7318-Z1	D653		•	•		7533-Z	D540		•	•				
MAXIMA	1992	1994	7318-Z1	D653		•	•		7421-Z1	D595		•	•				
MAXIMA	2000	2001	7783-AZ	D815		•	•		7533-Z	D540		•	•				
MAXIMA	2000	2001	7783-Z	D815		•	•		7533-Z	D540		•	•				
MAXIMA	2002	2003	7783-AZ	D815		•	•		7777-Z	D900		•	•				
MAXIMA	2004	2008	7870-Z	D969		•	•		7784-Z	D905		•	•				
MAXIMA	2009	2009	8449-Z1	D1374		•	•										
MAXIMA	2010	2017	8449-Z1	D1374		•	•		8501-Z	D1393		•	•				
MICRA	2005	2007	8553-Z	D1435		•	•										
NOTE	2014	2017	8804-Z	D1592		•	•		1689	S1020						•	
NX	1991	1993	7389-Z	D510		•	•		1438	S638						•	
NX	1991	1993	7428-Z	D549		•	•		1438	S638						•	
NX	1991	1993	7389-Z	D510		•	•		7390-Z	D511		•	•			•	
NX	1991	1993	7428-Z	D549		•	•		7390-Z	D511		•	•			•	
PLATINA	2002	2010	8256-Z	D1146		•	•		1695	S1029						•	
PRIMERA	1992	1992	7342-Z	D462		•	•										
PULSAR NX	1983	1984	7155-Z	D233		•	•		1373	S532						•	
PULSAR NX	1985	1990	7155-Z1	D275		•	•		8106	S533						•	

MODELO Model	AÑO Inicio	AÑO Final	BALATAS DELANTERAS			AZUL	FIX	SFC	SHD	BALATAS TRASERAS			AZUL	FIX	SFC	SHD	FT OW
			Pastilla	Zapata	Características					Pastilla	Zapata	Características					
PULSAR NX	1988	1989								8106	S533						•
SAKURA	1982	1983	780-Z	D37		•				1373	S532						•
SAKURA	1984	1987	7155-Z	D233		•				1373	S532						•
SAKURA	1984	1987	7155-Z1	D275		•	•			1373	S532						•
SAMURAI	1980	1984	7155-Z	D233		•				1373	S532						•
SEDAN	1980	1984	7059-Z	D41		•											•
SENTRA	1982	1983	7155-Z	D233		•				1373	S532						•
SENTRA	1983	1983								1373	S532						•
SENTRA	1983	1983	7155-Z	D233		•				8106	S533						•
SENTRA	1983	1985								8106	S533						•
SENTRA	1984	1985								8106	S533						•
SENTRA	1986	1990	7155-Z1	D275		•	•			8106	S533						•
SENTRA	1991	1994	7388-Z	D509			•			1438	S638						•
SENTRA	1991	1994	7389-Z	D510	SE / GXE	•	•			1438	S638						•
SENTRA	1991	1994	7388-Z	D509			•			7390-Z	D511	•	•				•
SENTRA	1991	1994	7389-Z	D510	SE / GXE	•	•			7390-Z	D511	•	•				•
SENTRA	1995	1999	7546-Z	D668	GST / GSX 1.6L	•	•			1438	S638						•
SENTRA	1995	1999	7546-Z	D668	GST / GSX 1.6L	•	•			7547-Z	D669	•	•				•
SENTRA	1996	2000	7428-Z	D549	GSS 2.OL	•	•			7547-Z	D669	•	•				•
SENTRA	2000	2001	7342-Z	D462		•	•			1525	S762						•
SENTRA	2001	2001	7318-Z	D430	SE 2.OL	•	•			7533-Z	D540	•	•				•
SENTRA	2001	2006	7342-Z	D462	Motor 1.8L	•	•			1525	S779						•
SENTRA	2002	2006			Caliper Brembo					7777-Z	D900	•	•				•
SENTRA	2006	2006	7318-Z	D430	Motor 2.5L	•				7777-Z	D900	•	•				•
SENTRA	2007	2012	8449-Z	D1374	Spec-V	•	•			8405-Z	D1288						•
SENTRA	2007	2012	7318-Z2	D815	SER	•	•			8405-Z	D1288	•	•				•
SENTRA	2007	2012	7318-Z2	D815		•	•			1462	S919						•
SENTRA	2013	2016	7318-Z2	D815		•	•			1708	S1046						•
SENTRA	2016	2018	7318-Z2	D815		•	•			8501-Z	D1393		•				•
STANZA	1987	1989	7171-Z	D266		•	•			1381	S607						•
STANZA	1990	1992	7342-Z	D462		•	•			1381	S607						•
STANZA	1990	1992	7342-Z	D462		•	•										•
STATION WAGON	1980	1984	780-Z	D37		•											•
TIIDA	2007	2018	8456-Z	D1345		•	•			1624	S924						•
TSUBAME	1993	2004	7389-Z	D510		•	•			1438	S638						•
TSURU	1984	1989	7155-Z	D233		•				1373	S532						•
TSURU	1984	1989	71X5-Z	F013		•				1373	S532						•
TSURU	1984	1991	7155-Z1	D275		•	•			1373	S532						•
TSURU	1985	1987	7155-Z	D233	Samurái	•				1373	S532						•
TSURU	1985	1987	7155-Z1	D275	Samurái	•	•			1373	S532						•
TSURU	1985	1987	71X5-Z	F013	Samurái	•				1373	S532						•
TSURU	1992	2017	7389-Z	D510	GS, GSI, GSII	•	•			1438	S638						•
VERSA	2012	2018	8804-Z	D1592	1.6L	•	•			1689	S1020						•

NISSAN TRUCK

720	1980	1981	795-Z1	D161		•											•
720	1983	1983	795-Z1	D161		•											•
720	1985	1986	7170-Z	D265		•	•										•
ARMADA	2005	2005	7918-Z	D1015		•	•			7945-Z	D1041	•	•				•
ARMADA	2006	2006	8300-Z	D1183		•	•			7945-Z	D1041	•	•				•
ARMADA	2007	2011	8403-Z	D1286		•	•			7945-Z	D1041	•	•				•
ARMADA	2012	2017	8403-Z1	D1509		•	•			7945-Z	D1041	•	•				•
AXXESS	1990	1995	7342-Z	D462		•	•										•
D21 Pickup	1986	1992	7171-Z	D266		•				1399	S574						•
D21 Pickup	1993	2008	7228-Z	D333		•	•			1399	S574						•
FRONTIER	1998	2004	7228-Z	D333		•	•			1399	S574						•
FRONTIER	1998	2004	7228-Z	D333		•	•			1433	S631						•
FRONTIER	2003	2004	7876-Z	D830		•	•			1399	S574						•
FRONTIER	2003	2004	7876-Z	D830		•	•			1433	S631						•
FRONTIER	2006	2013	8200-Z	D1094		•	•			1399	S574						•
FRONTIER	2005	2017	8200-Z	D1094		•	•			8206-Z	D1100	•	•				•
ICHI VAN	1987	1994	7170-Z	D265		•	•			8123	S406						•
ICHI VAN	1987	1994	7171-Z	D266		•				8123	S406						•
JUKE	2011	2017	7318-Z2	D815		•	•			8501-Z	D1393		•				•
JUKE	2014	2017	8449-Z1	D1374	Nismo RS	•	•			8405-Z	D1288	•	•				•
KICKS	2017	2018	9269-Z	D2038		•											•
MURANO	2003	2008	7870-Z	D969		•	•			7784-Z	D905	•	•				•
MURANO	2009	2012	7870-Z	D969		•	•			8405-Z	D1288	•	•				•
MURANO	2011	2014	8221-Z	D888		•	•			7784-Z	D905	•	•				•
MURANO	2014	2014	8221-Z	D888		•	•			8405-Z	D1288	•	•				•

MODELO Model	AÑO Inicio	AÑO Final	BALATAS DELANTERAS			AZUL	FIX	SPC	SHD	BALATAS TRASERAS			AZUL	FIX	SPC	SHD	FT OW
			Pastilla	Zapata	Características					Pastilla	Zapata	Características					
MURANO	2015	2017	8877-Z	D1649						8405-Z	D1288						
NP300	2009	2015	7228-Z	D333						1740	S1094						
NP300 Frontier	2016	2018	9141-Z	D1911						1X36	FT117						
NV 2500	2014	2016	8523-Z	D1411						8523-Z	D1411						
NV 350	2013	2018	8310-Z	D1191						1399	S574						
PATHFINDER	1987	1988	7228-Z	D333													
PATHFINDER	1988	1994	7228-Z	D333						7290-Z	D401						
PATHFINDER	1989	1994	7228-Z	D333						1399	S574						
PATHFINDER	1996	2004	7566-Z1	D855						1433	S631						
PATHFINDER	2001	2001	7910-Z	D855						1433	S631						
PATHFINDER	2004	2004	7918-Z	D1015						7945-Z	D1041						
PATHFINDER	2005	2012	8200-Z	D1094	Motor V6 4.0L					8204-Z	D1101						
PATHFINDER	2008	2012	8221-Z	D888	Motor V8 5.6L					8204-Z	D1101						
PATHFINDER	2013	2017	8877-Z	D1649						8405-Z	D1288						
PICKUP	1980	1988	780-Z	D37						8123	S406						
PICKUP	1985	1989	780-Z	D37						2169	S571						
PICKUP	1989	1989	7170-Z	D265						8123	S406						
PICKUP	1990	1992	7170-Z	D265						1399	S574						
PICKUP D21	1994	1997	7171-Z	D266	4X4					1433	S631						
PICKUP D21	1995	1997	7171-Z	D266	4X4					1399	S574						
PICKUP D21	1993	2007	7228-Z	D333						1433	S631						
QUEST	1993	2002	7456-Z	D576						1452	S665						
QUEST	2004	2009	7910-Z	D855						7784-Z	D905						
ROGUE	2008	2013	8449-Z1	D1374						8405-Z	D1288						
TITAN	2004	2005	7918-Z	D1015						7945-Z	D1041						
TITAN	2005	2007	8300-Z	D1183						7945-Z	D1041						
TITAN	2008	2010	8403-Z	D1286						7945-Z	D1041						
TITAN	2011	2017	8403-Z1	D1509						7945-Z	D1041						
URVAN	2000	2001	7228-Z	D333						1399	S574						
URVAN	2002	2013	8310-Z	D1191						1399	S574						
URVAN	2013	2018	8310-Z	D1191	NV350					1399	S574						
VAN	1987	1988	7228-Z	D333													
XTERRA	2000	2001	7703-Z	D830						1433	S631						
XTERRA	2002	2004	7876-Z	D830						1433	S631						
XTERRA	2006	2007	8200-Z	D1094						8204-Z	D1101						
XTERRA	2008	2013	8200-Z	D1094						8206-Z	D1100						
X-TRAIL	2002	2007	7910-Z	D855						7784-Z	D905						
X-TRAIL	2008	2014	8449-Z1	D1374						7784-Z	D905						
X-TRAIL	2015	2018	8906-Z1	D1736	3 Filas de Asientos, Hybrid					8501-Z	D1393						
X-TRAIL	2015	2018	8449-Z2	D1737	2 Filas de Asientos					8501-Z	D1393						

OLDSMOBILE

88	1992	1993	7384-Z	D505						1394	S636						
88	1994	1995	7384-Z1	D623						1394	S636						
88	1996	1999	7384-Z1	D623						1394	S636						
98	1985	1986	7136-Z	D215						2165T	S552						
98	1987	1990	7136-Z	D215													
98	1991	1993	7384-Z	D505						1394	S636						
98	1994	1996	7384-Z1	D623						1394	S636						
ACHIEVA	1992	1998	7385-Z	D506						2164	S553						
ALERO	1999	2004	7735-Z	D752						7387-Z2	D714						
AURORA	1995	1996	7384-Z1	D623						7387-Z2	D714						
AURORA	1997	1997	7574-Z	D699						7387-Z2	D714						
AURORA	1998	2003	7693-Z	D699A						7387-Z2	D714						
CALAIS	1985	1987	7192-Z	D289						2164	S553						
CUTLASS	1978	1981	7070-Z	D154	Supreme												
CUTLASS	1982	1989	7070-CZ	D183	Ciera												
CUTLASS	1983	1986	7136-Z	D215	Ciera												
CUTLASS	1985	1986	7192-Z	D289	Ciera					2165T	S552						
CUTLASS	1985	1989	7070-AZ1	D154	Supreme					2117ATT	S514						
CUTLASS	1985	1992	7136-Z	D215	Ciera					2165T	S552						
CUTLASS	1987	1989	7070-CZ	D183	Cruiser					2165T	S552						
CUTLASS	1987	1990	7136-Z	D215	Cruiser					2165T	S552						
CUTLASS	1988	1989	7265-Z	D376	Supreme					2117ATT	S514						
CUTLASS	1988	1989	7070-AZ1	D154	Supreme												
CUTLASS	1988	1990	7192-Z	D289	Calais					2164	S553						
CUTLASS	1988	1993	7265-Z	D376	Supreme												
CUTLASS	1990	1991	7385-Z	D506	Calais					2164	S553						
CUTLASS	1993	1993	7136-Z	D215	Ciera					1394	S636						
CUTLASS	1994	1996	7136-Z	D215	Ciera												

MODELO Model	AÑO Inicio	AÑO Final	BALATAS DELANTERAS			AZUL	FIX	SPC	SHD	BALATAS TRASERAS			AZUL	FIX	SPC	SHD	FT OW
			Pastilla	Zapata	Características					Pastilla	Zapata	Características					
CUTLASS	1994	1997	7265-Z	D376	Supreme	•	•		7387-Z2	D714		•	•				
CUTLASS CALAIS	1978	1979	7070-Z	D154		•	•										
CUTLASS SALON	1975	1977	728-AZ	D52		•	•	•									
CUTLASS SALON	1978	1979	7070-Z	D154		•	•										
CUTLASS SUPREME	1972	1977	728-AZ	D52		•	•	•									
DELTA 88	1986	1990	7136-Z	D215		•	•										
DELTA 88	1991	1991	7136-Z	D215		•	•		1394	S636						•	
F85	1972	1972	728-AZ	D52		•	•	•									
FIRENZA	1985	1988	7192-Z	D289		•	•		2164	S553						•	
INTRIGUE	1998	2002	7693-Z	D699A		•	•		7387-Z2	D714		•	•				
LSS	1996	1999	7384-Z1	D623		•	•										
OMEGA	1973	1979	728-AZ	D52		•	•	•									
OMEGA	1980	1984	7070-CZ	D183		•	•										
REGENCY	1997	1998	7384-Z1	D623		•	•										
TORONADO	1972	1978	728-AZ	D52		•	•	•									
TORONADO	1979	1981	7070-Z	D154		•	•		7070-AZ1	D154		•	•				
TORONADO	1980	1985	7070-AZ1	D154		•	•	•	2117ATT	S514						•	
TORONADO	1992	1992	7384-Z	D505		•	•		7387-Z	D508		•	•				
VISTA CRUISER	1972	1975	728-AZ	D52		•	•	•									

OLDSMOBILE TRUCK

BRAVADA	1991	1994	7070-AZ1	D154		•	•	•								
BRAVADA	1996	1996	7070-AZ1	D154		•	•	•	2117ATT	S514						•
BRAVADA	1996	1996	7634-Z	D767		•	•		2117ATT	S514						•
BRAVADA	1997	2001	7593-Z	D726		•	•		7596-Z	D729		•	•			
BRAVADA	2002	2004	7759-Z	D882		•	•		7760-Z	D883		•	•			
SILHOUETTE	1990	1991	7136-Z	D215		•	•		2165T	S552						•
SILHOUETTE	1992	1993	7384-Z	D505		•	•									
SILHOUETTE	1994	1996	7384-Z1	D623		•	•									
SILHOUETTE	1997	2004	7693-Z	D699A		•	•		7387-Z3	D814		•	•			
SILHOUETTE	2002	2004	7720-Z	D844		•	•		7387-Z3	D814		•	•			

PEUGEOT

106	1997	2000	76X1A-Z	F128		•	•									
206	2000	2000	8342-Z	D1221		•	•		7X59-Z	F015		•	•			
206	2000	2000				•	•		7X59-Z	F015		•	•			
206	2000	2002	76X3-Z	F134		•	•		7X59-Z	F015		•	•			
206	2001	2008	8333-Z	D1213		•	•		7X59-Z	F015		•	•			
206	2003	2008	8309-Z	D1190		•	•		1Y16	FT035						•
207	2008	2011	76X3-Z	F134		•	•		7X59-Z	F015		•	•			
207	2009	2010	76X3-Z	F134	RC Turbo / Trendy	•	•		7X59-Z	F015		•	•			
207	2009	2011	76X3-Z	F134		•	•		1Y16	FT035						•
207	2012	2013	7Y14-Z	F245		•	•		7234-Z	D340		•	•			
208	2014	2016	8333-Z	D1213		•	•		7335-Z	D340		•	•			
208	2014	2016	8979-Z	D1749	GT	•	•		7335-Z	D340		•	•			
301	2013	2016	8333-Z	D1213		•	•									
306	1993	2000				•	•		7X59-Z	F015		•	•			
306	1993	2000	8342-Z	D1221		•	•		7X59-Z	F015		•	•			
306	1993	2000				•	•		7X59-Z	F015		•	•			
306	1997	1997	8342-Z	D1221	SR	•	•		7X59-Z	F015		•	•			
306	1997	1997	76X1A-Z	F128		•	•		7X59-Z	F015		•	•			
306	1998	2000				•	•		7X59-Z	F015		•	•			
306	1998	2002	8342-Z	D1221		•	•		7X59-Z	F015		•	•			
306	2001	2002	8309-Z	D1190		•	•		7X59-Z	F015		•	•			
306	2001	2002				•	•		7X59-Z	F015		•	•			
307	2003	2010	7Y14-Z	F245		•	•		7234-Z	D340		•	•			
308	2009	2012	8922-Z	D1696		•	•		86X4-Z	F376						
308	2010	2012	8922-Z	D1696	CC	•	•		86X4-Z	F376		•	•			
308	2012	2012	8922-Z	D1696	RC	•	•		86X4-Z	F376		•	•			
405	1989	1989				•	•		7335-Z	D340		•	•			
405	1990	1991				•	•		7335-Z	D340		•	•			
405	1990	1991				•	•		7335-Z	D340		•	•			
405	1997	1999			SRI	•	•		7234-Z	D340		•	•			
406	2000	2002	8342-Z	D1221		•	•		7X48-Z	F126		•	•			
406	2000	2004	8342-Z	D1221		•	•									
407	2006	2009	8362A-Z	D1245		•	•									
505	1990	1991				•	•		7335-Z	D340		•	•			
2008	2014	2016	8Y30-Z	F466		•	•		7335-Z	D340		•	•			
3008	2011	2012	8922-Z	D1696		•	•		86X4-Z	F376		•	•			

MODELO Model	AÑO Inicio	AÑO Final	BALATAS DELANTERAS			BALATAS TRASERAS				AZUL	FIX	SPC	SHD	FT OW
			Pastilla	Zapata	Características	Pastilla	Zapata	Características						
PEUGEOT TRUCK														
GRAND RAID	2007	2011	8333-Z	D1213				1Y19	FT040					
GRAND RAID	2012	2012	8333-Z	D1213				1Y19	FT040					
MANAGER	2009	2012	8748-Z	D1540				7Y87-Z	F222					
PARTNER	2004	2008	723X-Z	F027				1Y19	FT040					
PARTNER	2008	2008	8309-Z	D1190				1Y19	FT040					
PARTNER	2009	2012	8333-Z	D1213				1Y19	FT040					
PARTNER	2012	2012	8333-Z	D1213	TDI			1Y19	FT040					
PARTNER	2013	2015	8942-Z	D1717	Tepee			9151-Z	D1926					
PLYMOUTH														
ACCLAIM	1990	1990						7303-Z	D415					
ACCLAIM	1991	1991	7404-AZ	D522				7303-Z1	D512					
ACCLAIM	1991	1994	7404-AZ	D522										
BREEZE	1995	2000	7530-AZ	D650				7438-BZ	D641					
BREEZE	1996	1997	7530-AZ	D650				1481	S698					
BREEZE	1996	2000	7530-AZ	D650				1481	S716					
DUSTER	1974	1974	7017-Z	D84										
FURY	1974	1974	7019-Z	D86										
FURY	1975	1978						2089T	S445					
GRAN FURY	1975	1977	7019-Z	D86										
GRAN FURY	1982	1984	7017-Z	D84				2089T	S445					
HORIZON	1983	1990						1365	S519					
SUNDANCE	1988	1990						7303-Z	D415					
VALIANT	1973	1974	7017-Z	D84										
VALIANT	1975	1976	7017-Z	D84				2089T	S445					
VALIANT	1981	1981	7017-Z	D84				2089T	S445					
VALIANT DUSTER	1974	1976	7017-Z	D84				2089T	S445					
VALIANT SUPER BEE	1973	1979	7017-Z	D84				2089T	S445					
VOLARE K	1982	1982	7097-Z	D170										
VOLARE K	1983	1988	7134-Z	D220										
PLYMOUTH TRUCK														
GRAND VOYAGER	1987	1988						2168T	S538					
GRAND VOYAGER	1987	1990						2168T	S538					
PONTIAC														
1000	1983	1987						2164	S553					
6000	1982	1983	7070-CZ	D183										
6000	1983	1983	7136-Z	D215										
6000	1984	1984	7070-CZ	D183				2165T	S552					
6000	1984	1991	7136-Z	D215				2165T	S552					
6000	1985	1989	7192-Z	D289				2165T	S552					
6000	1990	1990	7136-Z	D215				7267-Z	D378					
BONNEVILLE	1972	1973	728-AZ	D52										
BONNEVILLE	1982	1982	7070-AZ1	D154										
BONNEVILLE	1983	1986	7070-AZ1	D154				2117ATT	S514					
BONNEVILLE	1987	1991	7136-Z	D215										
BONNEVILLE	1992	1993	7384-Z	D505										
BONNEVILLE	1994	1999	7384-Z1	D623										
BONNEVILLE	2000	2004	7693-Z	D699A				7387-Z2	D714					
BONNEVILLE	2004	2005	7574-Z	D699				7387-Z2	D714					
CATALINA	1972	1981	728-AZ	D52										
FIREBIRD	1972	1980	728-AZ	D52										
FIREBIRD	1980	1981	728-AZ	D52				2117ATT	S514					
FIREBIRD	1980	1981	728-AZ	D52				7070-AZ1	D154					
FIREBIRD	1982	1992	7070-AZ1	D154				2117ATT	S514					
FIREBIRD	1988	1989	7300-Z	D412				2117ATT	S514					
FIREBIRD	1988	1989	7070-AZ1	D154										
FIREBIRD	1988	1989	7300-Z	D412										
FIREBIRD	1993	1993	7384-Z	D505				2117ATT	S514					
FIREBIRD	1993	1993	7384-Z	D505										
FIREBIRD	1994	1997	7384-Z1	D623				2117ATT	S514					
FIREBIRD	1994	1997	7384-Z1	D623										
FIREBIRD	1994	1997	7384-Z1	D623										
FIREBIRD	1998	2001	7618-Z	D749	Trans-Am			7619-Z	D750					
FIREBIRD	1998	2002	7618-Z	D749				7619-Z	D750					
FIREFLY	2000	2000	7331-Z	D451										

MODELO Model	AÑO Inicio	AÑO Final	BALATAS DELANTERAS			AZUL	FIX	SFC	SHD	BALATAS TRASERAS			AZUL	FIX	SFC	SHD	FT OW
			Pastilla	Zapata	Características					Pastilla	Zapata	Características					
G3	2006	2008	8385-Z	D1269		•	•		1Y08	FT025						•	
G3	2009	2010	7779-Z1	D1035		•	•		1547	S814						•	
G4	2005	2006	7855-Z	D956		•	•										
G5	2007	2007	7932-Z	D1028		•	•		7937-Z	D1033		•	•				
G5	2007	2010	7855-Z	D956		•	•		7937-Z	D1033		•	•				
G5	2008	2010	8270-Z	D1160		•	•		7937-Z	D1033		•	•				
G6	2005	2010	7932-Z	D1028		•	•		7937-Z	D1033		•	•				
G6	2006	2010	8270-Z	D1160		•	•		7937-Z	D1033		•	•				
GRAND AM	1985	1998	7192-Z	D289		•	•										
GRAND AM	1990	1990	7192-Z	D289		•	•		2164	S553						•	
GRAND AM	1991	1998	7385-Z	D506		•	•		2164	S553						•	
GRAND AM	1996	1998	7554-Z	D673		•	•		2164	S553						•	
GRAND AM	1999	2001	7620-Z	D752		•	•		7387-Z2	D714		•	•				
GRAND AM	1999	2005	7735-Z	D752		•	•		7387-Z2	D714		•	•				
GRAND PRIX	1972	1977	728-AZ	D52		•	•										
GRAND PRIX	1978	1981	7070-Z	D154		•	•										
GRAND PRIX	1983	1987	7070-AZ1	D154		•	•	•	2117ATT	S514						•	
GRAND PRIX	1988	1988	7265-Z	D376		•	•		2117ATT	S514						•	
GRAND PRIX	1988	1993	7265-Z	D376		•	•										
GRAND PRIX	1994	1996	7265-Z	D376		•	•		7387-Z2	D714		•	•				
GRAND PRIX	1997	2003	7693-Z	D699A		•	•		7387-Z2	D714		•	•				
GRAND PRIX	2005	2008	7980-Z	D1075		•	•										
GRAND PRIX	2005	2008							8207-Z	D922			•				
LEMANS	1972	1975	728-AZ	D52		•	•										
LEMANS	1980	1981	7070-AZ1	D154		•	•										
PARISIENNE	1972	1981	728-AZ	D52		•	•										
PARISIENNE	1984	1984	728-AZ	D52		•	•										
PHOENIX	1978	1979	728-AZ	D52		•	•										
PHOENIX	1980	1984	7070-CZ	D183		•	•										
PURSUIT	2005	2006	7855-Z	D956		•	•		7937-Z	D1033		•	•				
PURSUIT	2005	2006	7932-Z	D1028		•	•		7937-Z	D1033		•	•				
SOLSTICE	2006	2009	7932-Z	D1028		•	•		7957-Z1	D1095		•	•				
SUNBIRD	1985	1991	7192-Z	D289		•	•		2164	S553						•	
SUNBIRD	1985	1994	7192-Z	D289		•	•										
SUNBIRD	1992	1994	7385-Z	D506		•	•		2164	S553						•	
SUNFIRE	1992	2002	7385-Z	D506		•	•		2164	S553						•	
T1000	1981	1981							2164	S553						•	
T1000	1983	1987							2164	S553						•	
VENTURA	1976	1976	728-AZ	D52		•	•										
PONTIAC TRUCK																	
AZTEK	2001	2005	7720-Z	D844		•	•		1500	S780						•	
AZTEK	2001	2005	7720-Z	D844		•	•		7387-Z2	D714		•	•				
AZTEK	2001	2005	7720-Z	D844		•	•		7387-Z3	D814		•	•				
MONTANA	1999	2005	7693-Z	D699A		•	•		7387-Z3	D814		•	•				
MONTANA	2002	2004	7693-Z	D699A		•	•		7387-Z3	D814		•	•				
MONTANA	2002	2004	7720-Z	D844		•	•		7387-Z3	D814		•	•				
MONTANA	2005	2009	7980-Z	D1075		•	•		7999-Z	D1093		•	•				
TORRENT	2006	2006	7794-Z1	D913		•	•		1500	S780						•	
TORRENT	2007	2009	8381-Z	D1264		•	•		8391-Z	D1275		•	•				
TRANS SPORT	1990	1991	7136-Z	D215		•	•		2165T	S552						•	
TRANS SPORT	1992	1993	7384-Z	D505		•	•										
TRANS SPORT	1994	1996	7384-Z1	D623		•	•		1394	S636						•	
TRANS SPORT	1997	1999	7693-Z	D699A		•	•										
VIBE	2003	2006	7824-Z	D923		•	•										
VIBE	2007	2008	7824-Z	D923		•	•		1529	S785						•	
VIBE	2009	2010	8330-Z	D1210		•	•		8332-Z	D1212		•	•				
VIBE	2009	2010	8331-Z	D1211		•	•		8332-Z	D1212		•	•				
VIBE	2009	2010	8330-Z	D1210		•	•		8463-Z1	D1423		•	•				
VIBE	2009	2010	8331-Z	D1211		•	•		8463-Z1	D1423		•	•				
PORSCHE TRUCK																	
CAYENNE	2003	2010	7878-Z	D1014	GTS / S / Tu			•	7908-AZ	D978	Rin 17"	•	•				
CAYENNE	2003	2010	8366-Z	D1014				•	7908-AZ	D978		•	•				
CAYENNE	2004	2010	7911-Z	D1007	S / Turbo			•	7908-AZ	D978	Rin 17"	•	•				
CAYENNE	2011	2013	8642-Z	D1452				•	8643-Z	D1453			•				
CAYENNE	2011	2014			Turbo				8643-Z	D1453			•				
RAM																	
700	2015	2018	9195-Z	D1970	Club Cab			•	2Y20	FT111						•	

MODELO Model	AÑO Inicio	AÑO Final	BALATAS DELANTERAS			AZUL	FIX	SPC	SHD	BALATAS TRASERAS			AZUL	FIX	SPC	SHD	FT OW
			Pastilla	Zapata	Características					Pastilla	Zapata	Características					
700	2015	2018	7W04-Z	F498	SLT Cabina sencilla, Rapid	•	•										
1500	2000	2000	7627-Z	D758	VAN	•				2171T	S583						•
1500	2003	2003	7866-Z	D966	VAN	•				2171T	S583						•
1500	2011	2012	8507-Z	D1399		•				8508-Z	D1400		•				•
1500	2011	2018	7991-Z	D1084		•				7869-Z	D967		•				•
2500	1999	1999	7259-Z1	D369		•	•			2171T	S583						•
2500	1999	1999	7339A-Z	D459MA		•				2171T	S583						•
2500	1999	2003	7677-Z	D655	VAN	•				2171T	S583						•
2500	2000	2001	7694-Z	D821		•				2171T	S583						•
2500	2001	2002	7694-Z1	D859		•				2171T	S583						•
2500	2003	2008	7864-Z	D965		•				2171T	S583						•
2500	2009	2011	8507-Z	D1399		•				8508-Z	D1400		•				•
3500	1999	2003	7677-Z	D655	VAN	•				2171T	S583						•
3500	2000	2000	7694-Z	D821		•				2171T	S583						•
3500	2001	2001	7694-Z1	D859		•				2171T	S583						•
3500	2009	2010	8507-Z	D1399		•				8508-Z	D1400		•				•
4000	2010	2017	8507-Z	D1399		•				8508-Z	D1400		•				•
4500	2011	2015	8446-Z	D1335		•				8446-Z	D1335			•			•
5500	2011	2015	8446-Z	D1335		•				8446-Z	D1335			•			•
2500 HD	2011	2017	8507-Z	D1399	HEAVY DUTY	•				8508-Z	D1400		•				•
3500 HD	2011	2017	8507-Z	D1399		•				8508-Z	D1400		•				•
PROMASTER 1500	2014	2017	8748-Z	D1540		•				9017-Z	D1490			•			•
PROMASTER 2500	2014	2017	8748-Z	D1540		•				8974-Z	D1746			•			•
PROMASTER 3500	2014	2017	8748-Z	D1540		•				8974-Z	D1746			•			•

RENAULT

ALLIANCE	1984	1986								1350	S501						•
CLIO	2001	2010	8256-Z	D1146		•	•			1695	S1029						•
CLIO	2015	2015	8844-Z	D1627		•				7234-Z	D340		•				•
CLIO EURO	2007	2009	8553-Z	D1435		•	•			7234-Z	D340		•				•
CLIO SPORT	2001	2006	8844-Z	D1627		•	•			7X59-Z	F015		•				•
CLIO SPORT	2002	2007	8255-Z	D1145		•	•			7X59-Z	F015		•				•
ENCORE	1985	1986								1350	S501						•
FLUENCE	2011	2014	8844-Z	D1627		•	•			7234-Z	D340		•				•
LAGUNA GRAND TOUR	2001	2007								7874-Z	D973		•				•
LAGUNA II	2003	2006	7664-Z	D794		•	•			7842-Z1	D1060		•				•
LAGUNA II	2003	2007								7874-Z	D973		•				•
LECAR	1977	1981	793-Z	D49		•											•
LOGAN	2015	2018	9061-Z	D1830		•	•			1734	S1085						•
MEGANE	1995	1995	8342-Z	D1221		•	•										•
MEGANE	2001	2004	8255-Z	D1145		•	•			7234-Z	D340		•				•
MEGANE	2001	2004	8255-Z	D1145		•	•			7X59-Z	F015		•				•
MEGANE II	2004	2007	7Y21-Z	F253		•	•			7335-Z	D340		•				•
MEGANE II	2004	2010	7664-Z	D794		•	•			7335-Z	D340		•				•
MEGANE II	2005	2008	7Y13-Z	F244		•	•			7335-Z	D340		•				•
R12	1971	1981	793-Z	D49		•											•
R12	1980	1980	793-Z	D49	TS	•											•
R12	1980	1981	793-Z	D49		•											•
R12	1980	1981	7X3-Z	F012		•											•
R17	1972	1976	793-Z	D49		•											•
R18	1980	1983	7X3-Z	F012		•											•
R5	1976	1981	793-Z	D49		•											•
R5	1981	1983	7X3-Z	F012		•											•
R5	1984	1984	7X59-Z	F015		•	•										•
R5	1986	1986	7X3-Z	F012		•											•
R5 LS	1980	1981	793-Z	D49		•											•
SAFRANE	2009	2012	8221-Z	D888		•	•			8405-Z	D1288		•				•
SAFRANE	2012	2015	7783-Z	D815		•	•			8405-Z	D1288		•				•
SAFRANE	2013	2015	7783-AZ	D815	3.5LTS	•	•			8405-Z	D1288		•				•
SCALA	2011	2013	8311-Z	D1193		•	•			1525	S1034						•
SCENIC	2001	2004	8255-Z	D1145		•	•			7335-Z	D340		•				•
SCENIC II	2005	2008	7Y21-Z	F253		•	•			7335-Z	D340		•				•

RENAULT TRUCK

CAPTURE	2018	2018	8844-Z	D1627		•	•			1694	S1039						•
DUSTER	1975	1976	7017-Z	D84		•				2089T	S445						•
DUSTER	2013	2017	8844-Z	D1627		•	•			1694	S1039						•
FLUENCE	2017	2017	8X51-Z	F386		•	•										•
KANGOO	2004	2009	76X3-Z	F134		•	•			1Y28	FT038						•
KANGOO	2004	2018	76X1A-Z	F128	Con Sensor de Desgaste	•				1Y28	FT038						•

MODELO Model	AÑO Inicio	AÑO Final	BALATAS DELANTERAS			AZUL	FIX	SFC	SHD	BALATAS TRASERAS			AZUL	FIX	SFC	SHD	FT OW
			Pastilla	Zapata	Características					Pastilla	Zapata	Características					
KANGOO	2004	2018	8254-Z	D1499	Sin Sensor de Desgaste	•	•			1Y28	FT038						•
KOLEOS	2009	2015	8221-Z	D888		•	•			8405-Z	D1288	•	•				•
KOLEOS	2017	2018	8449-Z2	D1737		•	•			7784-Z	D905		•				•
SANDERO	2010	2017	8256-Z	D1146	Con Sensor de Desgaste	•	•			1695	S1029						•
SANDERO	2010	2017	71X4-Z	F051	Sin Sensor de Desgaste	•	•			1695	S1029						•
STEPWAY	2010	2017	8256-Z	D1146	Con Sensor de Desgaste	•	•			1695	S1029						•
STEPWAY	2010	2017	71X4-Z	F051	Sin Sensor de Desgaste	•	•			1695	S1029						•
TRAFIC	2007	2014	7X56-Z	F103		•	•			7Y81-Z	F327	•					•

SAAB

900	1997	1998								7614-Z	D709	•	•				
9000	1997	1998								7614-Z	D709	•	•				
9-2X	2005	2006	7880-Z	D929				•									
9-3	1999	2003								7614-Z	D709	•	•				
9-3	2003	2003								7874-Z	D973	•	•				
9-3	2004	2008								7957-Z1	D1095	•	•				
9-3	2008	2008	7873-Z	D972				•		7957-Z1	D1095	•	•				
9-3	2010	2011	7873-Z	D972						7874-Z	D973	•	•				
9-5	1999	1999								7614-Z	D709	•	•				
9-5	2000	2005								7286-Z	D396	•	•				
9-5	2010	2011	8536-Z	D1421				•									

SAAB TRUCK

9-7X	2005	2005	7759-Z	D882				•	•	7760-Z	D883	•	•				
9-7X	2006	2009	8282-Z	D1169				•	•	7760-Z	D883	•	•				

SATURN

OUTLOOK	2008	2010	8410-Z	D1169				•	•	7760-Z	D883	•	•				
SC SERIES	1991	1992	7595-Z	D728				•									
SC SERIES	1991	1996	7386-Z	D507				•									
SC SERIES	1997	2002	7595-Z	D728				•									
SL SERIES	1991	1992	7595-Z	D728				•									
SL SERIES	1991	1996	7386-Z	D507				•									
SL SERIES	1997	2002	7595-Z	D728				•									
SW SERIES	1993	1996	7386-Z	D507				•									
SW SERIES	1997	2001	7595-Z	D728				•									

SEAT

CORDOBA	2001	2003	7578-Z	D704	Rotores de 256mm	•	•			7335-Z	D340	•	•				
CORDOBA	2001	2003	7709-Z	D768	Rotores de 256mm 4 seguros de 42.5mm	•	•			7335-Z	D340	•	•				
CORDOBA	2004	2009	7Y08-Z	F221	2.0L	•	•			7335-Z	D340	•	•				
CORDOBA	2005	2008	8555-Z	D1437	Rotores de 288mm	•	•			7335-Z	D340	•	•				
IBIZA	2001	2003	7578-Z	D704	Stella	•	•			7335-Z	D340	•	•				
IBIZA	2003	2008	7709-Z	D768	1.6L	•	•			7335-Z	D340	•	•				
IBIZA	2003	2008	8555-Z	D1437	T1.8	•	•			7335-Z	D340	•	•				
IBIZA	2009	2014	7709-Z	D768	Style	•	•			7335-Z	D340	•	•				
IBIZA	2009	2016	8212-Z	D1107	Reference	•	•			7335-Z	D340	•	•				
IBIZA	2011	2014	8212-Z	D1107	Bocanegra / FR 1.4T	•	•			8213-Z	D1108	•	•				
IBIZA	2003	2008	7Y08-Z	F221	2.0L	•	•			7335-Z	D340	•	•				
LEON	2001	2006	7710-AZ	D687	Cupra	•	•			7335-Z	D340	•	•				
LEON	2002	2008	7569-Z	D694		•	•			7335-Z	D340	•	•				
LEON	2002	2008	7578-Z	D704		•	•			7335-Z	D340	•	•				
LEON	2002	2008	7709-Z	D768		•	•			7335-Z	D340	•	•				
LEON	2002	2008	7710-AZ	D687		•	•			7335-Z	D340	•	•				
LEON	2010	2015	8212-Z	D1107	Base, Cupra R	•	•			8213-Z	D1108	•	•				
LEON	2015	2017	8989-Z	D1760		•	•			7335-Z	D340	•	•				
TOLEDO	2001	2004	7710-AZ	D687	Turbo	•	•			7335-Z	D340	•	•				
TOLEDO	2001	2007	7709-AZ	D768	R16	•	•			7335-Z	D340	•	•				
TOLEDO	2001	2007	7709-Z	D768	R15	•	•			7335-Z	D340	•	•				
TOLEDO	2005	2005	7434-AZ	D555		•	•			7335-Z	D340	•	•				
TOLEDO	2006	2007	8212-Z	D1107		•	•			8213-Z	D1108	•	•				
TOLEDO	2014	2016	8212-Z	D1107		•	•			7335-Z	D340	•	•				

SEAT TRUCK

ATECA	2017	2018	8989-Z	D1760				•	•	8990-Z	D1761		•				
ALHAMBRA	2002	2008	7757-AZ	D880	Rotores de 313mm	•	•			7755-AZ	D877	•	•				
ALHAMBRA	2002	2008	7757-Z	D880	Rotores de 313mm	•	•			7755-AZ	D877	•	•				
ALHAMBRA	2002	2008	7757-AZ	D880	Rotores de 313mm	•	•			7755-BZ	D877		•				
ALHAMBRA	2002	2008	7757-Z	D880	Rotores de 313mm	•	•			7755-BZ	D877		•				
ALTEA	2005	2012	7709-Z	D768	Rotores de 280mm	•	•			7335-Z	D340		•				

MODELO Model	AÑO Inicio	AÑO Final	BALATAS DELANTERAS							BALATAS TRASERAS						
			Pastilla	Zapata	Características	AZUL	FIX	SPC	SHD	Pastilla	Zapata	Características	AZUL	FIX	SPC	SHD
ALTEA	2005	2012	8212-Z	D1107	Rotores de 288mm y Rotores 312mm	•	•			7335-Z	D340		•	•		
FREETRACK	2009	2012	8212-Z	D1107		•	•			8213-Z	D1108		•	•		
SUBARU																
BRZ	2014	2016	7880-Z	D929						8218-Z	D1114		•			
BRZ	2014	2016	7880-Z	D929						8231-Z	D1124		•	•		
IMPREZA	2007	2011	7880-Z	D929						8218-Z	D1114		•			
IMPREZA	2009	2015	7880-Z	D929	WR• / GT / SE / STI					8218-Z	D1114		•			
IMPREZA	2014	2014	7902-Z	D1001									•			
LEGACY	2000	2001								7637-Z	D770		•			
LEGACY	2002	2005	7880-Z	D929						7637-Z	D770		•			
LEGACY	2005	2009	7983-Z	D1078						7637-Z	D770		•			
LEGACY	2005	2012	7880-Z	D929						8218-Z	D1114		•			
LEGACY	2009	2014	7880-Z	D929	2.5i					8218-Z	D1114		•			
LEGACY	2010	2014	7983-Z	D1078	3.6R					8231-Z	D1124		•			
LEGACY	2015	2016	7983-Z	D1078	2.5i, 3.6R								•			
WRX	2015	2016	7983-Z	D1078						8218-Z	D1114		•			
WRX STI	2015	2016	7902-Z	D1001									•			
XV CROSSTREK	2014	2016	7880-Z	D929						8218-Z	D1114		•			
SUBARU TRUCK																
B9 TRIBECA	2006	2007	7983-Z	D1078						8231-Z	D1124		•			
BAJA	2003	2006	7880-Z	D929						7637-Z	D770		•			
FORESTER	2010	2015	7880-Z	D929	2.5i					8218-Z	D1114		•			
FORESTER	2014	2016	7983-Z	D1078	2.0 XT					8231-Z	D1124		•			
OUTBACK	2002	2004	7880-Z	D929						7637-Z	D770		•			
OUTBACK	2005	2014	7880-Z	D929	2.5i					8218-Z	D1114		•			
OUTBACK	2010	2014	7983-Z	D1078	3.6R					8231-Z	D1124		•			
TRIBECA	2008	2014	7983-Z	D1078						8231-Z	D1124		•			
SUZUKI																
AERIO	2002	2006								1461	S630					•
AERIO	2006	2007	8315-Z	D1195						1461	S630					•
CIAZ	2015	2016	8827-Z	D1614					•	1Y90	FT115					•
CIAZ	2016	2016	8Y31-Z	F528					•	1Y90	FT115					•
FORENZA	2004	2008	7779-Z1	D1035					•	7939-Z	D1036		•			•
IGNIS	2017	2018	9304-Z	D2005									•			•
KIZASHI	2010	2013	8449-Z1	D1374					•	7418-Z1	D537		•			•
RENO	2005	2008	7779-Z1	D1035					•	7939-Z	D1036		•			•
S-CROSS	2014	2015	7783-Z	D815					•	1641	S954					•
S-CROSS	2014	2015	7783-Z	D815					•	7418-Z1	D537		•			•
S-CROSS	2016	2018	8Y31-Z	F466					•	8463-Z1	D1423		•			•
SWIFT	2007	2017	8827-Z	D1614	GA, GLS				•	1Y25	FT060					•
SWIFT	2013	2018	8738-Z	D1454	GLX, Motor 1.4L, Sport Motor 1.6L				•	8463-Z1	D1423		•			•
SX4	2007	2008	7318-Z1	D653					•	7418-Z1	D537		•			•
SX4	2009	2014	7783-AZ	D815					•	1641	S954					•
SX4	2009	2014	7783-AZ	D815					•	7418-Z1	D537		•			•
SUZUKI TRUCK																
CARRY	2002	2004	9304-Z	D2005	1300 CC											•
EQUATOR	2009	2010	8200-Z	D1094						8206-Z	D1100		•			•
EQUATOR	2011	2012	8403-Z1	D1509						8206-Z	D1100		•			•
GRAND VITARA	1999	1999	7680-Z	D807					•	1506	S738					•
GRAND VITARA	2000	2005	7559-Z	D680					•	1506	S738					•
GRAND VITARA	2006	2008	8307-Z	D1188					•	1623	S921					•
GRAND VITARA	2009	2013	8307-Z	D1188					•	7784-Z	D905		•			•
SIDEKICK	1990	1990	7305-Z	D418					•							•
SIDEKICK	1991	1995	7305-Z	D418					•	1440	S641					•
SIDEKICK	1996	1998	7305-Z	D418					•							•
SIDEKICK	1996	1998	7559-Z	D680					•							•
VITARA	1999	2004	7680-Z	D807					•	1506	S738					•
VITARA	2016	2018	8Y31-Z	F466					•	8463-Z1	D1423		•			•
X-90	1996	1998	7305-Z	D418					•							•
XL7	2002	2004	7559-Z	D680					•							•
XL7	2007	2009	8381-Z	D1264					•	8391-Z	D1275		•			•
TOYOTA																
AVALON	2000	2004								7701-Z	D828		•			•
AVALON	2005	2007	7896-Z	D906					•	7701-Z	D828		•			•
CAMRY	2002	2006	7787-Z	D908	4 Cilindros				•	7701-Z	D828		•			•

MODELO Model	AÑO Inicio	AÑO Final	BALATAS DELANTERAS			AZUL	FIX	SFC	SHD	BALATAS TRASERAS			AZUL	FIX	SFC	SHD	FT OW
			Pastilla	Zapata	Características					Pastilla	Zapata	Características					
CAMRY	2005	2006	7896-Z	D906	6 Cilindros	.	.		7701-Z	D828		.	.				
CAMRY	2007	2017	8331-Z2	D1293			.		8332-Z	D1212		.	.				
CAMRY	2018	2018							8332-Z	D1212		.	.				
CELICA	1986	1986	7153-Z	D242		.						.	.				
CELICA	1986	1991	7153-Z	D242		.						.	.				
CELICA	1990	1993	7247-Z	D356		.						.	.				
CELICA	1994	1995	7357-Z1	D718		.						.	.				
CELICA	1994	1995	7357-Z	D476					
CELICA	1994	1997	7441-Z	D562					
CELICA	1996	1999	7357-Z1	D718					
CELICA	2000	2005	7695-Z	D822					
COROLLA	1972	1980	795-Z	D57		.						.	.				
COROLLA	1988	1991	7153-Z	D242		.						.	.				
COROLLA	1993	1997	7441-Z	D562					
COROLLA	1998	1999	7611-Z	D741					
COROLLA	2000	2002	7611-Z	D741		.	.		1515	S750		.	.			.	
COROLLA	2004	2008	7824-Z	D923		.	.		1515	S832		.	.			.	
COROLLA	2007	2008	8780-Z	D1571		.	.		1515	S832		.	.			.	
COROLLA	2007	2008	7824-Z	D923	XRS	.	.		8781-Z	D1572		.	.			.	
COROLLA	2009	2009	8331-Z	D1211	XRS	.	.		8463-Z1	D1423		.	.			.	
COROLLA	2009	2015	8330-Z	D1210	Versión C	.	.		1635	S945		.	.			.	
COROLLA	2010	2018	8330-Z	D1210		.	.		8463-Z1	D1423		.	.			.	
CORONA	1981	1982	7047-Z	D114		.						.	.				
CRESSIDA	1978	1980	795-Z	D57		.						.	.				
CRESSIDA	1990	1992	7320-Z	D433		.						.	.				
ECHO	2000	2000	7704-Z	D831					
ECHO	2001	2002	7695-Z	D822					
MARK II	1972	1976	795-Z	D57		.						.	.				
MATRIX	2003	2008	7824-Z	D923					
MATRIX	2009	2013	8331-Z	D1211	Motor 2.4L AWD	.	.		8332-Z	D1212		.	.			.	
MATRIX	2009	2013	8330-Z	D1210	Motor 1.8L	.	.		8463-Z1	D1423		.	.			.	
MATRIX	2009	2013	8331-Z	D1211	Motor 2.4L FWD	.	.		8463-Z1	D1423		.	.			.	
MR2	1985	1995	7153-Z	D242		.						.	.				
MR2	2000	2006	7695-Z	D822	Spyder				
PASEO	1992	1999	7153-Z	D242		.						.	.				
PRIUS	2010	2013	8538-Z	D1184		.	.		1635	S945		.	.			.	
PRIUS	2010	2017	8538-Z	D1184		.	.		8463-Z1	D1423		.	.			.	
SOLARA	2001	2003				.			7701-Z	D828		.	.				
SOLARA	2004	2008	7896-Z	D906		.	.		7701-Z	D828		.	.				
TERCEL	1986	1990	7153-Z	D242		.						.	.				
TERCEL	1991	1999	7153-Z	D242		.						.	.				
YARIS	2004	2006	8674-Z	D1475		.	.		1621	S917		.	.			.	
YARIS	2007	2016	8538-Z	D1184	SE Hatchback	.	.		1635	S945		.	.			.	
YARIS	2007	2016	8301-Z	D1184		.	.		1621	S917		.	.			.	
YARIS R	2016	2018	9081-Z	D1852		.	.		1437	S991		.	.			.	
TOYOTA TRUCK																	
4RUNNER	1990	1991	7298-Z1	D436		.			1397	S589		.	.			.	
4RUNNER	1992	2000	7298-Z3	D611		.			1397	S589		.	.			.	
4RUNNER	2001	2002	7549-Z	D436		.	.		1397	S764		.	.			.	
4RUNNER	2003	2016	7877-Z	D976		.	.	.	7487-Z	D606		.	.			.	
AVANZA	2007	2018	8671-Z	D1471		.	.		1Y15	FT034		.	.			.	
FJ CRUISER	2007	2015	7877-Z	D976		.	.	.	7487-Z	D606		.	.			.	
HIACE	2006	2015	8455-Z	D1344	Carga	.	.		2W61	FT015		.	.			.	
HIACE	2013	2018	8455-Z	D1344		.	.		1Y97	S589		.	.			.	
HIACE	2015	2018	8455-Z	D1344	GL (Pasajeros)	.	.		1397	S764		.	.			.	
HIGHLANDER	2008	2013	8436-Z	D1324		.	.		8437-Z	D1325		.	.			.	
HIGHLANDER	2014	2016	8436-Z	D1324		.	.		8500-Z	D1391		.	.			.	
HILUX	2004	2008	7549-Z	D436		.	.		7487-Z	D606		.	.			.	
HILUX	2009	2013	8776-Z	D1567		.	.		1358	S871		.	.			.	
HILUX	2012	2015	8731-Z	D1523		.	.		1358	S505		.	.			.	
HILUX	2009	2018	7877-Z	D976	Doble Cabina 6 Birlos	.	.		1681	S1012		.	.			.	
HILUX	2016	2018	9236-Z1	D2058	Cabina sencilla 5 Birlos	.	.		1358	S871		.	.			.	
LAND CRUISER	1990	1990	7069-Z	D137		
LAND CRUISER	1993	1997				.			7487-Z	D606		.	.			.	
LAND CRUISER	1998	1999	7639-Z	D772		.	.		7487-Z	D606		.	.			.	
LAND CRUISER	2000	2007	7639-Z	D772		
LAND CRUISER	2008	2017	8419-Z	D1303		.	.	.	8420-Z	D1304		.	.			.	
PICKUP	1980	1983	7047-Z	D114		.	.		1358	S505		.	.			.	
PICKUP	1986	1987	7205-Z	D303		.	.		1358	S505		.	.			.	

MODELO Model	AÑO Inicio	AÑO Final	BALATAS DELANTERAS			AZUL	FIX	SPC	SHD	BALATAS TRASERAS			AZUL	FIX	SPC	SHD	FT OW
			Pastilla	Zapata	Características					Pastilla	Zapata	Características					
PICKUP	1990	1993	7298-Z1	D436		•											
PICKUP	1990	1995	7298-Z1	D436		•			1358	S505							•
PICKUP	1990	1995	7320-Z	D433		•			1358	S505							•
PICKUP	1990	1995	7298-Z1	D436		•			1397	S589							•
PICKUP	1990	1995	7320-Z	D433		•			1397	S589							•
PREVIA	1991	1994							1358	S505							•
RAV4	2004	2005	7738-Z	D862		•	•		7955-Z	D1051		•					•
RAV4	2006	2018	8330-Z	D1210	4 Cil. 2.5L, LE	•	•		8332-Z	D1212		•					•
RAV4	2006	2013	8331-Z	D1211	6 Cil. 3.5L / 3ra. Fila Asientos	•	•		8332-Z	D1212		•					•
RAV4	2014	2018	8331-Z	D1211	XLE / SE	•	•		8332-Z	D1212		•					•
SEQUOIA	2001	2002	7687-Z	D812		•		•	7487-Z	D606		•			•		•
SEQUOIA	2003	2007	7877-Z	D976		•	•	•	7487-Z	D606		•			•		•
SEQUOIA	2008	2017	8419-Z	D1303		•	•	•	8420-Z	D1304		•					•
SIENNA	2004	2010	7896-Z	D906		•			1358	S804							•
SIENNA	2004	2010	7896-Z	D906		•	•		7895-Z	D995		•					•
SIENNA	2011	2017	8436-Z	D1324			•	•	8500-Z	D1391			•				•
T100	1993	1998	7298-Z3	D611		•			1397	S589							•
T100	1993	1998	7485-Z	D604		•			1397	S589							•
TACOMA	1995	1995	7548-Z	D433		•			1397	S589							•
TACOMA	1995	1998	7549-Z	D436		•	•		1397	S589							•
TACOMA	1995	2004	7548-Z	D433		•			1358	S505							•
TACOMA	1995	2004	7549-Z	D436		•	•		1358	S505							•
TACOMA	1999	1999	7298-Z	D410		•	•		1358	S505							•
TACOMA	1999	1999	7298-Z	D410		•	•		1397	S589							•
TACOMA	2000	2002	7671-Z	D799		•	•		1358	S505							•
TACOMA	2000	2002	7671-Z	D799		•	•		1397	S589							•
TACOMA	2005	2017	7896-Z	D906	RWD	•	•		1358	S871							•
TACOMA	2005	2017	7877-Z	D976	TRD Sport 4x4	•	•	•	1358	S871							•
TUNDRA	2000	2002	7687-Z	D812		•	•		1397	S589							•
TUNDRA	2000	2002	7877-Z	D976		•	•	•	1397	S589							•
TUNDRA	2003	2003	7687-Z	D812		•	•		1397	S764							•
TUNDRA	2003	2006	7877-Z	D976		•	•	•	1397	S764							•
TUNDRA	2007	2017	8419-Z	D1303		•	•	•	8420-Z	D1304		•					•
VIGO	2010	2010	8776-Z	D1567		•											•

VOLKSWAGEN

ATLANTIC	1986	1987	7183-Z	F111		•	•		1354	S559							•
ATLANTIC	1986	1987	7183-Z1	D280	Rotor ventilado	•	•		1354	S559							•
BEETLE	1998	1998	7635-Z	D768		•	•		7335-Z	D340		•					•
BEETLE	1999	2011	7709-Z	D768	Rotor 280mm	•	•		7335-Z	D340		•					•
BEETLE	1999	2011	7710-AZ	D687	Rotor 288mm	•	•		7335-Z	D340		•					•
BEETLE	2012	2013	8760-Z	D1107	Motor 2.0 T	•	•		8656-Z	D1456			•				•
BEETLE	2012	2013	8760-Z	D1107	Motor 2.5L	•	•		7335-Z	D340		•					•
BEETLE	2014	2018	8212-Z	D1107	Motor 2.0 T	•	•		7335-Z	D340		•					•
BEETLE	2014	2018	7709-Z	D768	Motor 2.5L	•	•		7335-Z	D340		•					•
BORA	2005	2010	8212-Z	D1107		•	•		8213-Z	D1108		•					•
BORA	2010	2010	8212-Z	D1107		•	•		8656-Z	D1456			•				•
BRASILIA	1974	1983	735-Z	D30		•	•										•
CABRIO	1995	1997	7177-Z	D227		•	•		1450A	S662	Diseño Brasileño						•
CABRIO	1996	1997	7578-Z	D704		•	•		1450A	S662	Diseño Brasileño						•
CABRIO	1998	2003	7578-Z	D704		•	•		7335-Z	D340		•					•
CABRIOLET	1990	1991	7209-Z1	D569		•			1354	S559							•
CARIBE	1977	1985	7031-Z	D96		•			1354	S559							•
CARIBE	1986	1987	7183-Z	F111		•	•		1354	S559							•
CC	2009	2017	8212-Z	D1107		•	•		8213-Z	D1108		•					•
CORRADO	1990	1995				•			7234-Z	D340		•					•
CORSAR	1986	1988	7183-Z	F111		•	•										•
CORSAR	1986	1991	7183-Z1	D280	Rotor ventilado	•	•										•
DERBY	1994	1999	8768-Z	D1556		•	•										•
DERBY	2000	2000	756X-Z	D694		•	•		1450A	S662	Diseño Brasileño						•
DERBY	2000	2000	756X-Z	D694		•	•		7234-Z	D340	Diseño Brasileño						•
DERBY	2000	2000	7578-Z	D704		•	•		7234-Z	D340		•					•
DERBY	2000	2000	7177-Z	D227	Rotor ventilado	•	•		7234-Z	D340		•					•
DERBY	2000	2009	7578-Z	D704		•	•		1450A	S662	Diseño Brasileño						•
DERBY	2000	2009	7177-Z	D227	Rotor ventilado	•	•		1450A	S662	Diseño Brasileño						•
EOS	2007	2012	8212-Z	D1107		•	•		8213-Z	D1108		•					•
EOS	2011	2013	8212-Z	D1107		•	•		8656-Z	D1456			•				•
FOX	1973	1974	7031-Z	D96		•											•
FOX	1990	1993	7242-Z	D350	Rotor solido	•	•		1354	S559							•
FOX	1987	1993				•			1354	S559							•

MODELO Model	AÑO Inicio	AÑO Final	BALATAS DELANTERAS			AZUL	FIX	SFC	SHD	BALATAS TRASERAS			AZUL	FIX	SFC	SHD	FT OW
			Pastilla	Zapata	Características					Pastilla	Zapata	Características					
GOL	2009	2011	7569-Z	D694	Sin ABS	.	.	1450	S662							.	
GOL	2010	2014	8768-Z	D1556	Con ABS	.	.	1450A	S662	Diseño Brasileño						.	
GOL	2012	2018	8868-Z	D1641		.	.									.	
GOLF	2010	2013	8212-Z	D1107	Sportwagen	.	.	8213-Z	D1108		.	.				.	
GOLF	2012	2014	8212-Z	D1107		.	.	8656-Z	D1456		.	.				.	
GOLF A2	1986	1989	7177-Z	D227	Rotor Ventilado	.	.	1450A	S662	Diseño Brasileño						.	
GOLF A2	1986	1992	7143-Z	D227	Rotor solido	.	.	1450A	S662	Diseño Brasileño						.	
GOLF A2	1986	1992	7183-Z2	D569	GTI / Rotor ventilado	.	.	7234-Z	D340		.	.				.	
GOLF A2	1986	1989	7209-Z	D280	Rotor solido	.	.	1354	S559							.	
GOLF A2	1990	1992	7209-Z	D280	Rotor solido	.	.	1353	S495							.	
GOLF A2	1990	1992	7209-Z	D280	Rotor solido	.	.	1450A	S662							.	
GOLF A3	1987	1995	7177-Z	D227	Rotor ventilado	.	.	7234-Z	D340		.	.				.	
GOLF A3	1992	1999	7X83-Z	D569	Rotor solido	.	.	1450A	S662	Diseño Brasileño						.	
GOLF A3	1992	1999	7209-Z1	D569		.	.	7234-Z	D340		.	.				.	
GOLF A3	1992	1999	7710-AZ	D687		.	.	7234-Z	D340		.	.				.	
GOLF A3	1993	1999	7177-Z	D227	Rotor ventilado	.	.	1450A	S662	Diseño Brasileño						.	
GOLF A3	1996	1998	7569-Z	D694		.	.	1450A	S662	Diseño Brasileño						.	
GOLF A3	1996	1999	7177-Z	D227	Rotor ventilado	.	.	7335-Z	D340		.	.				.	
GOLF A3	1997	1997	7578-Z	D704		.	.	7335-Z	D340		.	.				.	
GOLF A4	2000	2005	7709-AZ	D768		.	.	7335-Z	D340		.	.				.	
GOLF A4	2000	2005	7709-Z	D768		.	.	7335-Z	D340		.	.				.	
GOLF A4	2000	2007	7710-AZ	D687		.	.	7335-Z	D340		.	.				.	
GOLF A4	2000	2007	7710-Z	D687		.	.	7335-Z	D340		.	.				.	
GOLF A6	2015	2015	8989-Z	D1760	TDI	.	.	7335-Z	D340		.	.				.	
GOLF A7	2017	2018	8989-Z	D1760	Sportwagen, CrossGolf	.	.	9008-Z	D1779		.	.				.	
GOLF GTI	2001	2003	7709-AZ	D768	Con Sensor de Desgaste	.	.	7335-Z	D340		.	.				.	
GOLF GTI	2001	2003	7709-Z	D768	Sin Sensor de Desgaste	.	.	7335-Z	D340		.	.				.	
GOLF GTI	2002	2002	7710-Z	D687		.	.	7335-Z	D340		.	.				.	
GOLF GTI	2003	2003	7710-AZ	D687		.	.	7335-Z	D340		.	.				.	
GOLF GTI	2007	2007	7710-AZ	D687		.	.	8213-Z	D1108		.	.				.	
GTI	2006	2010	8212-Z	D1107		.	.	8213-Z	D1108		.	.				.	
GTI	2014	2014	8212-Z	D1107		.	.	8656-Z	D1456		.	.				.	
GTI	2015	2017	8989-Z	D1760		.	.	9008-Z	D1779		.	.				.	
JETTA A2	1987	1991	7183-Z	F111	Rotor solido	.	.	1450A	S662	Diseño Brasileño						.	
JETTA A2	1987	1991	7209-Z	D280	Rotor solido	.	.	7234-Z	D340		.	.				.	
JETTA A2	1987	1992	7209-Z	D280	Rotor solido	.	.	1354	S559							.	
JETTA A2	1988	1992	72X9-Z	D569		.	.	1450A	S662	Diseño Brasileño						.	
JETTA A2	1988	1992	72X9-Z	D569		.	.	7234-Z	D340	Diseño Brasileño	.	.				.	
JETTA A2	1989	1992	8768-Z	D1556		.	.	1450A	S662	Diseño Brasileño						.	
JETTA A2	1989	1992	8768-Z	D1556		.	.	7234-Z	D340	Diseño Brasileño	.	.				.	
JETTA A2	1990	1990	7183-Z2	D569	Rotor ventilado	.	.	1354	S559							.	
JETTA A2	1990	1990	7143-Z	D227	Rotor solido	.	.	1450A	S662	Diseño Brasileño						.	
JETTA A2	1990	1990	7143-Z	D227	Rotor solido	.	.	7234-Z	D340	Diseño Brasileño	.	.				.	
JETTA A2	1990	1991	7183-Z1	D280	Rotor ventilado	.	.	7234-Z	D340		.	.				.	
JETTA A2	1990	1992	7183-Z2	D569	Rotor ventilado	.	.	7234-Z	D340		.	.				.	
JETTA A2	1991	1991	7183-Z1	D280	Rotor ventilado	.	.	1450A	S662	Diseño Brasileño						.	
JETTA A3	1987	1998	7177-Z	D227	Rotor ventilado	.	.	7234-Z	D340		.	.				.	
JETTA A3	1987	1999	7177-Z	D227	Rotor ventilado	.	.	1450A	S662	Diseño Brasileño						.	
JETTA A3	1992	1998	7X83-Z	D569	Rotor solido	.	.	1450A	S662	Diseño Brasileño						.	
JETTA A3	1992	1998	7209-Z1	D569	Rotor solido	.	.	7234-Z	D340		.	.				.	
JETTA A3	1993	1997	7572-Z	D684		.	.	1450A	S662	Diseño Brasileño						.	
JETTA A3	1993	1997	7572-Z	D684		.	.	7234-Z	D340	Diseño Brasileño	.	.				.	
JETTA A3	1993	1998	7X83-Z	D569	Rotor solido	.	.	7234-Z	D340		.	.				.	
JETTA A3	1995	1995	7209-Z	D280	Rotor solido	.	.	7234-Z	D340		.	.				.	
JETTA A3	1996	1996	7569-Z	D694		.	.	1450A	S662	Diseño Brasileño						.	
JETTA A3	1996	1996	7569-Z	D694		.	.	7234-Z	D340	Diseño Brasileño	.	.				.	
JETTA A3	1997	1999	7177-Z	D227	Rotor ventilado	.	.	7335-Z	D340		.	.				.	
JETTA A3	1998	1998	7709-Z	D768		.	.	1450A	S662	Diseño Brasileño						.	
JETTA A3	1998	1998	7709-Z	D768		.	.	7234-Z	D340	Diseño Brasileño	.	.				.	
JETTA A3	1998	1999	7578-Z	D704		.	.	1450A	S662	Diseño Brasileño						.	
JETTA A3	1998	1999	7578-Z	D704		.	.	7335-Z	D340	Diseño Brasileño	.	.				.	
JETTA A4	2000	2006	7710-AZ	D687		.	.	7335-Z	D340		.	.				.	
JETTA A4	2000	2010	7709-AZ	D768	Con Sensor de Desgaste	.	.	7335-Z	D340		.	.				.	
JETTA A4	2000	2010	7709-Z	D768	Sin Sensor de Desgaste	.	.	7335-Z	D340		.	.				.	
JETTA A4	2005	2010	8212-Z	D1107	Trendline	.	.	8213-Z	D1108		.	.				.	
JETTA A4	2010	2013	7709-AZ	D768	Trendline, Sport	.	.	7335-Z	D340		.	.				.	
JETTA A4	2011	2012	7709-Z	D768	Sport	.	.	7335-Z	D340		.	.				.	
JETTA A6	2010	2011	8212-Z	D1107	Bicentenario	.	.	8213-Z	D1108		.	.				.	
JETTA A6	2011	2013	7709-AZ	D768	TDI	.	.	8656-Z	D1456		.	.				.	
JETTA A6	2011	2013	7710-AZ	D687	TDI de Disco 288 mm	.	.	8656-Z	D1456		.	.				.	

MODELO Model	AÑO Inicio	AÑO Final	BALATAS DELANTERAS							BALATAS TRASERAS							FT OW
			Pastilla	Zapata	Características	AZUL	FIX	SPC	SHD	Pastilla	Zapata	Características	AZUL	FIX	SPC	SHD	
JETTA A6	2011	2018	8760-Z	D1107	GLI	•	•	•	8656-Z	D1456		•	•	•	•		
JETTA A6	2011	2018	8212-Z	D1107	Sport / Sedan 2.5L	•	•	•	7335-Z	D340		•	•	•	•		
JETTA A6	2013	2018	7709-AZ	D768	2.0L	•	•	•	7335-Z	D340		•	•	•	•		
JETTA A6	2013	2018	7709-AZ	D768	2.0L	•	•	•	1670	S999		•	•	•	•		
JETTA CLASICO	2008	2015	7709-Z	D768	Rotor 280mm	•	•	•	1670	S999		•	•	•	•		
JETTA CLASICO	2011	2015	7709-AZ	D768	Con Sensor de Desgaste	•	•	•	7335-Z	D340		•	•	•	•		
JETTA CLASICO	2011	2015	7709-Z	D768	Rotor 280mm	•	•	•	7335-Z	D340		•	•	•	•		
LUPO	2005	2009	7635-Z	D768		•	•	•	1450A	S662	Diseño Brasileño	•	•	•	•		
PASSAT	1990	1995	7177-Z	D227		•	•	•	7234-Z	D340		•	•	•	•		
PASSAT	1993	1995				•	•	•	7234-Z	D340		•	•	•	•		
PASSAT	1993	1997	7177-Z	D227		•	•	•	7335-Z	D340		•	•	•	•		
PASSAT	1996	1999	7710-Z	D687		•	•	•	7335-Z	D340		•	•	•	•		
PASSAT	1998	2005	7715-AZ	D840		•	•	•	7335-Z	D340		•	•	•	•		
PASSAT	2004	2004	7434-Z	D555		•	•	•	7335-Z	D340		•	•	•	•		
PASSAT	2006	2013	8212-Z	D1107		•	•	•	8213-Z	D1108		•	•	•	•		
PASSAT	2009	2013	8212-Z	D1107	CC	•	•	•	8213-Z	D1108		•	•	•	•		
PASSAT	2011	2011	8486A-Z	D1375	V6	•	•	•	8213-Z	D1108		•	•	•	•		
PASSAT	2011	2011	8212-Z	D1107		•	•	•	8656-Z	D1456		•	•	•	•		
PASSAT	2011	2014	8486A-Z	D1375		•	•	•	8656-Z	D1456		•	•	•	•		
PASSAT	2015	2017	8486A-Z	D1375		•	•	•	9008-Z	D1779		•	•	•	•		
POINTER	1999	2009	8288-Z	D350	Clip 43.5mm / Rotor Vent.	•	•	•	7Y31-Z	F235		•	•	•	•		
POINTER	2000	2001	7242-Z	D350	Rotor solido	•	•	•	1354	S559		•	•	•	•		
POINTER	2000	2004	777X-Z	F199	GTI	•	•	•	1450	S662	Diseño Alemán	•	•	•	•		
POINTER	2000	2009	8284-Z	D1173	Caliper Varga	•	•	•	1450	S662	Diseño Alemán	•	•	•	•		
POINTER	2004	2007	777X-Z	F199	GTI / Comfort	•	•	•	7Y31-Z	F235		•	•	•	•		
POINTER	1998	2007	7242-Z	D350	MI / City Rotor solido	•	•	•	1450	S662	Diseño Alemán	•	•	•	•		
POINTER	1999	2003	779X-Z	D350B	Clip 37.6mm / Rotor Vent.	•	•	•	1354	S559		•	•	•	•		
POINTER	1999	2005	8284-Z	D1173	Wagon Caliper Varga	•	•	•	1450	S662	Diseño Alemán	•	•	•	•		
POLO	2003	2007	7Y08-Z	F221		•	•	•	1450A	S662	Diseño Brasileño	•	•	•	•		
POLO	2013	2014	7709-Z	D768	TSI / Confort Line	•	•	•	7335-Z	D340		•	•	•	•		
POLO	2015	2018	9006-Z	D1776		•	•	•	1450	S662		•	•	•	•		
RABBIT	1983	1987	7183-Z1	D280	Convertible / Rotor ventilado	•	•	•	1353	S495		•	•	•	•		
RABBIT	2006	2009	8212-Z	D1107		•	•	•	8213-Z	D1108		•	•	•	•		
SEDAN	1980	1995				•	•	•	882	S315		•	•	•	•		
SEDAN	1995	2004	735-Z	D30		•	•	•	882	S315		•	•	•	•		
UP	2016	2018	8868-Z	D1641		•	•	•	1354	S559		•	•	•	•		
VENTO	2013	2018	9006-Z	D1776		•	•	•	15Y2	S810		•	•	•	•		

VOLKSWAGEN TRUCK

AMAROK	2011	2016	8767-Z	D1555		•	•	•	1667	S996		•	•	•	•	
CADDY	2014	2016	8212-Z	D1107		•	•	•	8656-Z	D1456		•	•	•	•	
CADDY	2017	2017	8989-Z	D1760		•	•	•				•	•	•	•	
COMBI	1980	2001	7021-Z	D45		•	•	•	8080	S397		•	•	•	•	
CRAFTER	2008	2017	8383-Z	D1268	Sin Sensor de Desgaste	•	•	•	8432-Z	D1318		•	•	•	•	
CRAFTER	2008	2017	79W3A-Z	F314	Con Sensor de Desgaste	•	•	•	79W4A-Z	F315		•	•	•	•	
CRAFTER	2008	2017	8430A-Z	D1316	Con Sensor de Desgaste	•	•	•	8431A-Z	D1317		•	•	•	•	
CROSSFOX	2007	2013	7709-AZ	D768	Con Sensor de Desgaste	•	•	•	1450A	S662	Diseño Brasileño	•	•	•	•	
CROSSFOX	2007	2013	7709-Z	D768	Sin Sensor de Desgaste	•	•	•	1450A	S662	Diseño Brasileño	•	•	•	•	
EUROVAN	2000	2003	7612-Z	D742		•	•	•	7755-AZ	D877		•	•	•	•	
EUROVAN	2000	2003	7612-Z	D742		•	•	•	7755-BZ	D877		•	•	•	•	
EUROVAN	2001	2002	7612-Z	D742		•	•	•	7754-Z	D877		•	•	•	•	
EUROVAN	2002	2005	7729-Z	D852	Con Sensor de Desgaste	•	•	•	7681A-Z	D808		•	•	•	•	
EUROVAN	2002	2005	7612-Z	D742	Sin Sensor de Desgaste	•	•	•	7681-Z	D808		•	•	•	•	
EUROVAN	2006	2009	7Y84A-Z	F262	Con Sensor de Desgaste	•	•	•	7921A-Z	D1018		•	•	•	•	
EUROVAN	2006	2009	7Y84-Z	F262	Sin Sensor de Desgaste	•	•	•	7921-Z	D1018		•	•	•	•	
PANEL	2000	2001	7729-Z	D852	Con Sensor de Desgaste	•	•	•	7681A-Z	D808		•	•	•	•	
PANEL	2000	2001	7612-Z	D742	Sin Sensor de Desgaste	•	•	•	7681-Z	D808		•	•	•	•	
POINTER PICK UP	1999	2010	8284-Z	D1173	Caliper Varga	•	•	•	1450B	S495		•	•	•	•	
ROUTAN	2009	2011	8389-Z	D1273		•	•	•	8438-Z	D1326		•	•	•	•	
ROUTAN	2012	2014	8481-Z	D1327	S	•	•	•	8438-Z	D1326		•	•	•	•	
ROUTAN	2012	2014	8800-Z	D1589		•	•	•	8811-Z	D1596		•	•	•	•	
SAVEIRO	2012	2016	8868-Z	D1641	Cabina Sencilla	•	•	•	1670	S999		•	•	•	•	
SAVEIRO	2015	2017	8868-Z	D1641	Doble cabina	•	•	•	7335-Z	D340		•	•	•	•	
SHARAN	2002	2008	7757-AZ	D880	Con Sensor de Desgaste	•	•	•	7755-AZ	D877		•	•	•	•	
SHARAN	2002	2008	7757-Z	D880	Sin Sensor de Desgaste	•	•	•	7755-AZ	D877		•	•	•	•	
SHARAN	2002	2008	7757-AZ	D880	Con Sensor de Desgaste	•	•	•	7755-BZ	D877		•	•	•	•	
SHARAN	2002	2008	7757-Z	D880	Sin Sensor de Desgaste	•	•	•	7755-BZ	D877		•	•	•	•	
SPORTVAN	2007	2010	7709-AZ	D768	Con Sensor de Desgaste	•	•	•	1450A	S662	Diseño Brasileño	•	•	•	•	
SPORTVAN	2007	2010	7709-Z	D768	Sin Sensor de Desgaste	•	•	•	1450A	S662	Diseño Brasileño	•	•	•	•	
TIGUAN	2012	2014	8486A-Z	D1375		•	•	•	8656-Z	D1456		•	•	•	•	

MODELO Model	AÑO Inicio	AÑO Final	BALATAS DELANTERAS			AZUL	FIX	SFC	SHD	BALATAS TRASERAS			AZUL	FIX	SFC	SHD	FT OW
			Pastilla	Zapata	Características					Pastilla	Zapata	Características					
TIGUAN	2009	2016	8486A-Z	D1375					8213-Z	D1108							
TOUAREG	2004	2006	7911-Z	D1007					7908-AZ	D978							
TOUAREG	2012	2014	7911-Z	D1007					8393-Z	D1277							
TOUAREG	2004	2006	7878-Z	D1014	TDI Ø Rotor 350mm				8393-Z	D1277	Pistón sencillo						
TOUAREG	2004	2008	8366-Z	D1014	TDI Ø Rotor 350mm				7908-AZ	D978	Pistón doble						
TOUAREG	2006	2010	8238-Z	D1129					7908-AZ	D978							
TOUAREG	2011	2017	8238-Z	D1129					8643-Z	D1453							
TRANSPORTER	1970	1972	734-Z	D45					8080	S397							
TRANSPORTER	1973	1979	7021-Z	D45													
TRANSPORTER	2010	2016	7Y84-Z	F262	Con Sensor de Desgaste				7921-Z	D1018							
TRANSPORTER	2010	2016	7Y84A-Z	F262	Sin Sensor de Desgaste				7921A-Z	D1018							
VW VAN	2002	2008	7242-Z	D350	Rotor solido				1670	S999							
VW VAN	2002	2009	756X-Z	D694	Rotor ventilado				1670	S999							
VW VAN	2007	2007	7242-Z	D350	Rotor solido				1450A	S662	Diseño Brasileño						
VW VAN	2007	2007	756X-Z	D694	Rotor ventilado				1450A	S662	Diseño Brasileño						
VOLVO																	
C30	2007	2013	7947-Z	D1044					7957-Z1	D1095							
C70	2006	2013	7947-Z	D1044					7957-Z1	D1095							
C70	2006	2013	8220-Z	D915					7957-Z1	D1095							
S40	1999	2004	7712-Z	D837					7713-Z	D838							
S40	2004	2004	7947-Z	D1044					7713-Z	D838							
S40	2004	2004	8220-Z	D915					7713-Z	D838							
S40	2005	2011	7947-Z	D1044					7957-Z1	D1095							
S40	2005	2012	8220-Z	D915					7957-Z1	D1095							
S60	2001	2009	7664-Z	D794					7665-Z	D795							
S60	2011	2017	8357-Z	D1305	Kinetic,316mm				8422-Z	D1307							
S60	2011	2017	8421-Z	D1306	Kinetic, 300mm Rotor de Freno				8422-Z	D1307							
S80	1999	2006	7664-Z	D794					7665-Z	D795							
S80	2007	2017	8357-Z	D1305					8422-Z	D1307							
S80	2007	2017	8421-Z	D1306	300mm Rotor de Freno				8422-Z	D1307							
V40	1999	2004	7712-Z	D837					7713-Z	D838							
V50	2005	2011	7947-Z	D1044					7957-Z1	D1095							
V50	2005	2011	8220-Z	D915					7957-Z1	D1095							
V60	2015	2017	8357-Z	D1305					8422-Z	D1307							
V60	2015	2017	8421-Z	D1306	300mm Rotor de Freno				8422-Z	D1307							
V70	2000	2007	7664-Z	D794					7665-Z	D795							
V70	2008	2010	8357-Z	D1305					8422-Z	D1307							
V70	2008	2010	8421-Z	D1306					8422-Z	D1307							
VOLVO TRUCK																	
XC60	2010	2010	8421-Z	D1306					8422-Z	D1307							
XC60	2010	2017	8525-Z	D1412					8422-Z	D1307							
XC70	2003	2007	7664-Z	D794					7665-Z	D795							
XC70	2008	2016	8357-Z	D1305					8422-Z	D1307							
XC70	2008	2016	8421-Z	D1306	300mm Rotor de Freno				8422-Z	D1307							
XC90	2003	2014	7904-Z	D1003	336mm Rotor de Freno												
XC90	2010	2014	8525-Z	D1412	R-Desing, 328mm Brake Rotors												



Sección 11 / Section 11

LISTA FRENO DE ESTACIONAMIENTO / PARKING BRAKE LISTING



Sección 11 / Section 11

LISTA FRENO DE ESTACIONAMIENTO / PARKING BRAKE LISTING

MODELO Model	AÑO Inicio	AÑO Final	BALATAS DELANTERAS				BALATAS TRASERAS				FT OW					
			Pastilla	Zapata	Características	AZUL	FIX	SPC	SHD	Pastilla		Zapata	Características	AZUL	FIX	SPC
CHEVROLET TRUCK																
AVALANCHE 2500	2002	2006								2192	S771	Freno de estacionamiento				
C3500	1991	1999								2086	S646	Freno de estacionamiento				
C3500	1991	1999								2086	S647	Freno de estacionamiento				
C3500	2001	2002								2086	S646	Freno de estacionamiento				
C3500	2001	2002								2086	S647	Freno de estacionamiento				
EXPRESS 2500	2003	2013								2192	S771	Freno de estacionamiento				
EXPRESS 3500	2010	2010								2192	S771	Freno de estacionamiento				
EXPRESS 3500	2012	2013								2192	S771	Freno de estacionamiento				
SILVERADO 1500 HD	2001	2007								2192	S771	Freno de estacionamiento				
SILVERADO 2500	1999	2013								2192	S771	Freno de estacionamiento				
SILVERADO 2500	2001	2006				2WD México				2192	S771	Freno de estacionamiento				
SILVERADO 2500 HD	2001	2010								2192	S771	Freno de estacionamiento				
SILVERADO 3500	2001	2004				2WD México				2192	S771	Freno de estacionamiento				
SILVERADO 3500	2001	2007								2192	S771	Freno de estacionamiento				
SILVERADO 3500 HD	2007	2010								2192	S771	Freno de estacionamiento				
SUBURBAN 2500	2001	2001				4WD				2192	S771	Freno de estacionamiento				
B7	1993	2002								1556	S824	Freno de estacionamiento				
C6	1990	2005								1556	S824	Freno de estacionamiento				
C7	1990	2005								1556	S824	Freno de estacionamiento				
F6	1997	2002								1556	S824	Freno de estacionamiento				
F7	1997	2002								1556	S824	Freno de estacionamiento				
KODIAC	1997	2005								1556	S824	Freno de estacionamiento				
SCHOOL BUS CHASSIS	1998	1991								2079B	S824	Freno de estacionamiento				
T6	2004	2005								1556	S824	Freno de estacionamiento				
T7	2004	2005								1556	S824	Freno de estacionamiento				
CHRYSLER																
300M	1999	2004								1441	S643	Freno de estacionamiento				
CIRRUS	1995	2000								1441	S643	Freno de estacionamiento				
CONCORDE	1995	1997								1441	S643	Freno de estacionamiento				
CONCORDE	2000	2004								1441	S643	Freno de estacionamiento				
DAYTONA	1990	1993								1441	S643	Freno de estacionamiento				
IMPERIAL	1990	1993								1441	S643	Freno de estacionamiento				
LEBARON	1990	1995								1441	S643	Freno de estacionamiento				
LHS	1995	1999								1441	S643	Freno de estacionamiento				
NEW YORKER	1990	1996								1441	S643	Freno de estacionamiento				
PT CRUISER	2001	2010								1441	S643	Freno de estacionamiento				
SEBRING	2001	2006								1441	S643	Freno de estacionamiento				
CHRYSLER TRUCK																
TOWN & COUNTRY	2001	2007								2202	S812	Freno de estacionamiento				
TOWN CAR & COUNTRY	1997	2000								2187	S761	Freno de estacionamiento				
DODGE																
CARAVAN	1997	2000								2187	S761	Freno de estacionamiento				
CARAVAN	2001	2002								2202	S812	Freno de estacionamiento				
DAKOTA	2003	2004								1543	S803	Freno de estacionamiento				
DAYTONA	1990	1993								1441	S643	Freno de estacionamiento				
DURANGO	2003	2006								1581	S852	Freno de estacionamiento				
DYNASTY	1991	1993								1441	S643	Freno de estacionamiento				
INTREPID	1993	2004								1441	S643	Freno de estacionamiento				
NEON	1995	2005								1441	S643	Freno de estacionamiento				
RAM 1500	2002	2006								1581	S852	Freno de estacionamiento				
RAM 1500	2003	2003				Van				1581	S852	Freno de estacionamiento				
RAM 1500	2007	2008								2192	S854	Freno de estacionamiento				
RAM 2500	2001	2003				Pickup				2192	S771	Freno de estacionamiento				
RAM 2500	2004	2005								2192	S771	Freno de estacionamiento				
RAM 2500	2006	2010								2192	S854	Freno de estacionamiento				
RAM 3500	2001	2003				Pickup				2192	S771	Freno de estacionamiento				
RAM 3500	2004	2005								2192	S771	Freno de estacionamiento				
RAM 3500	2005	2005				Pickup				2192	S771	Freno de estacionamiento				
RAM 3500	2006	2010								2192	S854	Freno de estacionamiento				
SHADOW	1993	1994								1441	S643	Freno de estacionamiento				
SPIRIT	1991	1994								1441	S643	Freno de estacionamiento				
STRATUS	1995	2006								1441	S643	Freno de estacionamiento				

MODELO Model	AÑO Inicio	AÑO Final	BALATAS DELANTERAS				BALATAS TRASERAS				AZUL	FTX	SFC	SHD	FT OW	
			Pastilla	Zapata	Características		Pastilla	Zapata	Características							
DODGE TRUCK																
GRAND CARAVAN	2000	2000								2187	S761	Freno de estacionamiento				•
GRAND CARAVAN	2001	2007								2202	S812	Freno de estacionamiento				•
RAM 2500	2001	2001								2192	S771	Freno de estacionamiento				•
RAM 2500	2003	2008				3/4 TON 4WD				2192	S771	Freno de estacionamiento				•
RAM 2500	2003	2008				3/4 TON 2WD México				2192	S771	Freno de estacionamiento				•
RAM 2500	2003	2008				3/4 TON 4WD México				2192	S771	Freno de estacionamiento				•
RAM 2500	2012	2012				SPORT 2WD, México				2192	S854	Freno de estacionamiento				•
EAGLE																
VISION	1993	1997								1441	S643	Freno de estacionamiento				•
FIAT TRUCK																
DUCATO	2012	2012								1722	S1067	Freno de estacionamiento				•
FORD																
900	1973	1973								2085	FT022	Freno de estacionamiento				•
8000	1973	1973								2085	FT022	Freno de estacionamiento				•
C750	1969	1973								2085	FT022	Freno de estacionamiento				•
C800	1969	1973								2085	FT022	Freno de estacionamiento				•
CROWN VICTORIA	1996	2002								1484	S745	Freno de estacionamiento				•
CT800	1969	1969								2085	FT022	Freno de estacionamiento				•
E SUPER DUTY	1996	2002								2086	S646	Freno de estacionamiento				•
E SUPER DUTY	1996	2002								2086	S647	Freno de estacionamiento				•
FORD TRUCK																
E-150	2006	2007								1581	S852	Freno de estacionamiento				•
E-250	2006	2007								2192	S854	Freno de estacionamiento				•
E-250 ECONOLINE	1999	2005								2192	S771	Freno de estacionamiento				•
E-350 ECONOLINE	1999	2005								2192	S771	Freno de estacionamiento				•
E-350 SUPER DUTY	2006	2007								2192	S854	Freno de estacionamiento				•
E-450 ECONOLINE	2003	2004								2086	S646	Freno de estacionamiento				•
E-450 ECONOLINE	2003	2004								2086	S647	Freno de estacionamiento				•
E-450 ECONOLINE	2003	2004								2192	S771	Freno de estacionamiento				•
E-550 ECONOLINE	2003	2003								2086	S646	Freno de estacionamiento				•
E-550 ECONOLINE	2003	2003								2086	S647	Freno de estacionamiento				•
EXCURSION	2000	2005								2192	S771	Freno de estacionamiento				•
EXPEDITION	1997	2002								1517	S752	Freno de estacionamiento				•
EXPLORER	1995	1999								1484	S701	Freno de estacionamiento				•
EXPLORER	2002	2005								1533	S791	Freno de estacionamiento				•
F SUPER DUTY	1990	1997								2086	S646	Freno de estacionamiento				•
F SUPER DUTY	1990	1997								2086	S647	Freno de estacionamiento				•
F-150	1997	2008								1517	S752	Freno de estacionamiento				•
F-150 HERITAGE	2000	2004								1517	S752	Freno de estacionamiento				•
F-250	1997	1999								1517	S752	Freno de estacionamiento				•
F-250 SUPER DUTY	1999	2004								2192	S771	Freno de estacionamiento				•
F-250 SUPER DUTY	2005	2010								2192	S854	Freno de estacionamiento				•
F-350 SUPER DUTY	1999	2004								2192	S771	Freno de estacionamiento				•
F-350 SUPER DUTY	2005	2012								2192	S854	Freno de estacionamiento				•
F53	1990	1997								2086	S646	Freno de estacionamiento				•
F53	1990	1997								2086	S647	Freno de estacionamiento				•
F59	1990	1994								2086	S646	Freno de estacionamiento				•
F59	1990	1994								2086	S647	Freno de estacionamiento				•
F59	1996	1997								2086	S646	Freno de estacionamiento				•
F59	1996	1997								2086	S647	Freno de estacionamiento				•
F59 STRIPPED CHASSIS	1995	1995								2086	S646	Freno de estacionamiento				•
F59 STRIPPED CHASSIS	1995	1995								2086	S647	Freno de estacionamiento				•
LT800	1969	1973								2085	FT022	Freno de estacionamiento				•
RANGER	1998	2002								1484	S745	Freno de estacionamiento				•
WINDSTAR	1995	1999								1484	S701	Freno de estacionamiento				•
600	1979	1983								1303	S842	Freno de estacionamiento				•
700	1979	1983								1303	S842	Freno de estacionamiento				•
800	1979	1983								1303	S842	Freno de estacionamiento				•
E-250 ECONOLINE	1995	2000								2192	S771	Freno de estacionamiento				•
ECONOLINE WAGON	2000	2002				México				2086	S646	Freno de estacionamiento				•
ECONOLINE WAGON	2000	2002				México				2086	S647	Freno de estacionamiento				•
EXPLORER	1990	1990				2WD, México				1484	S701	Freno de estacionamiento				•
EXPLORER	1998	1998				2WD				1484	S701	Freno de estacionamiento				•
EXPLORER LIMITED	2006	2010				2WD				1533	S791	Freno de estacionamiento				•
EXPLORER XLT	2007	2010				2WD				1533	S791	Freno de estacionamiento				•



Sección 12 / Section 12
Balata freno de disco
GUÍA ILUSTRADA / ILLUSTRATED GUIDE

BALATA FRENO DE DISCO

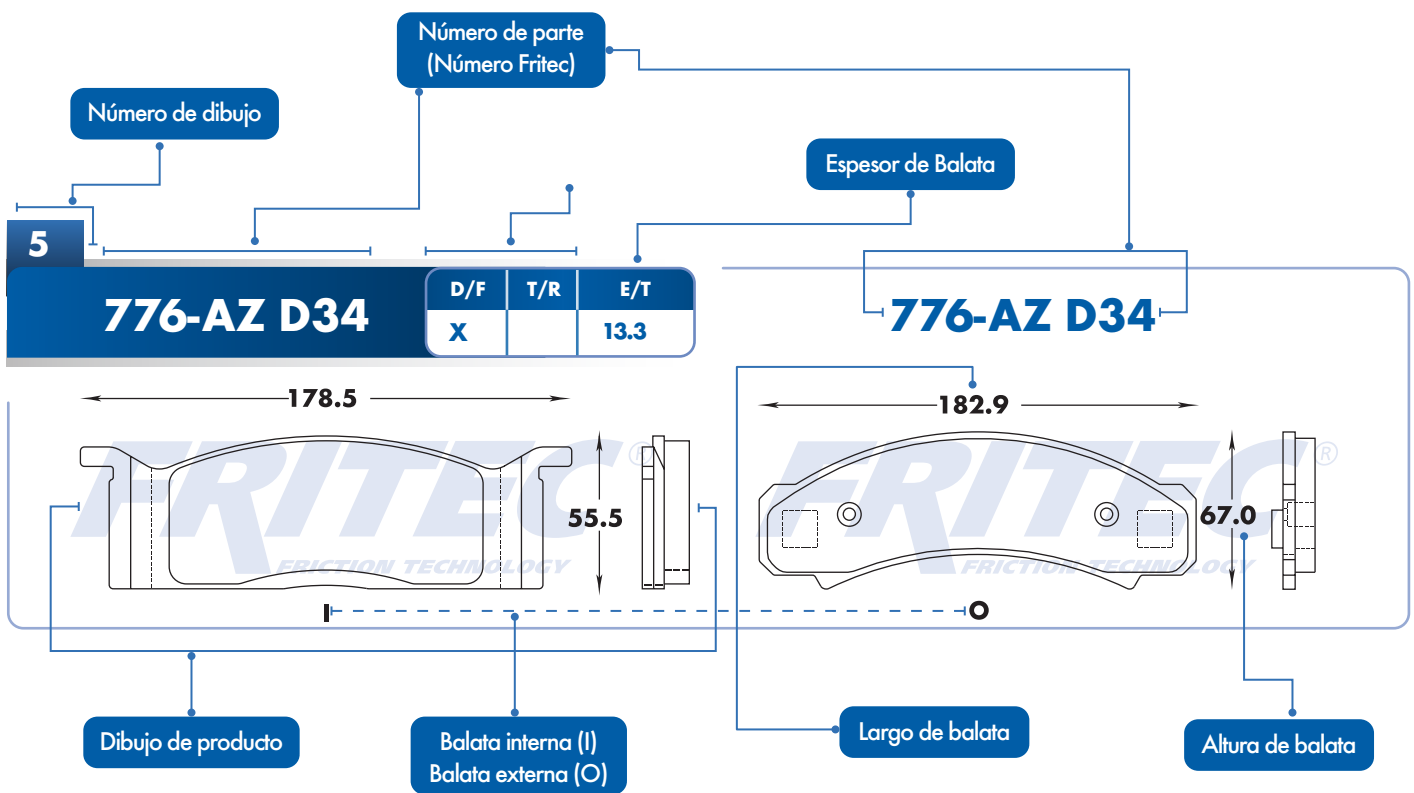

1

728-Z D52

D/F	T/R	E/T
X		15.9, 13.6

728-Z D52

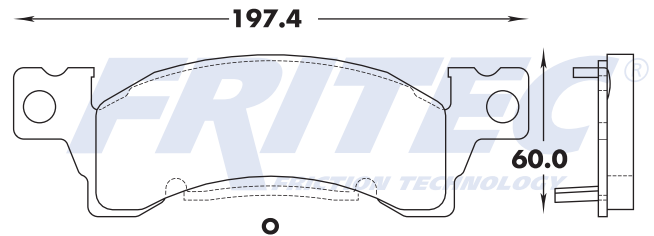
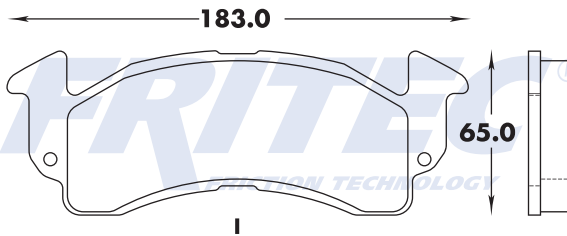

2

728-AZ D52

D/F	T/R	E/T
X		15.9, 13.6

728-AZ D52

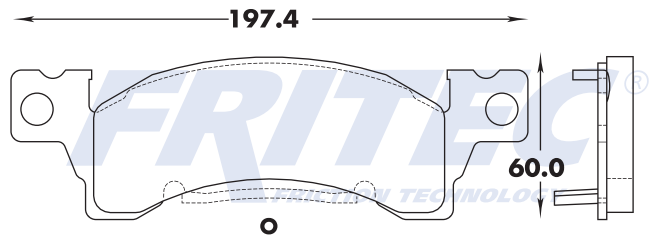
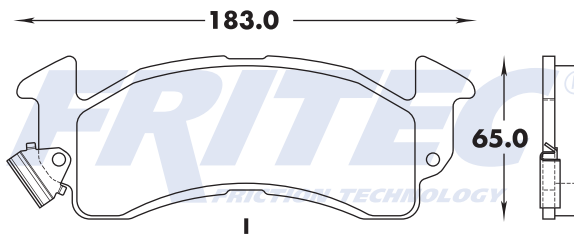

3

734-Z D45

D/F	T/R	E/T
X		14.9

734-Z D45

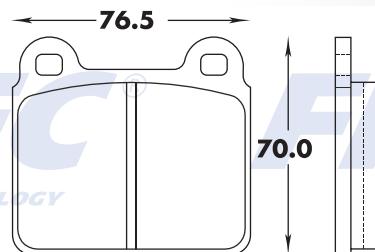

4

771-Z D20

D/F	T/R	E/T
X		14.4

771-Z D20

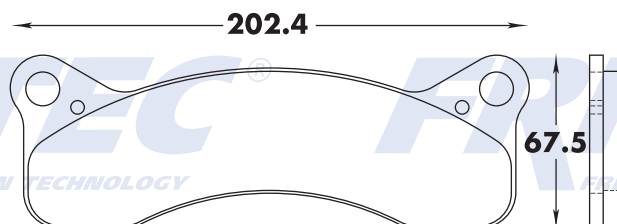

5

776-AZ D34

D/F	T/R	E/T
X		13.3

776-AZ D34

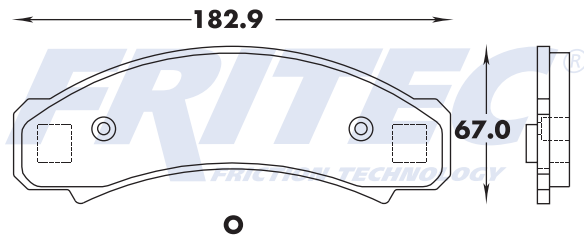
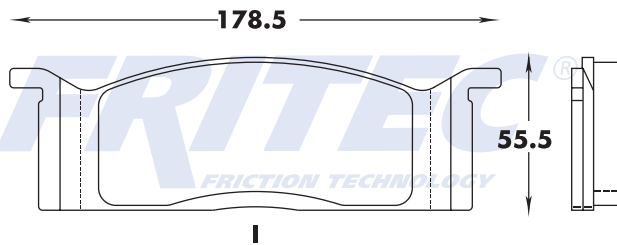

6

780-Z D37

D/F	T/R	E/T
X		17.5

780-Z D37

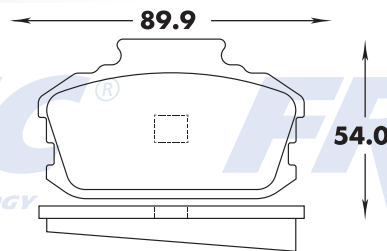

7

788-Z D50

D/F	T/R	E/T
X		17.1, 13.1

788-Z D50

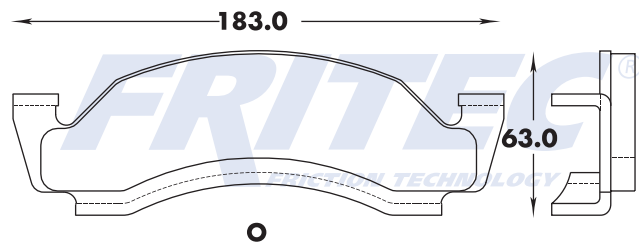
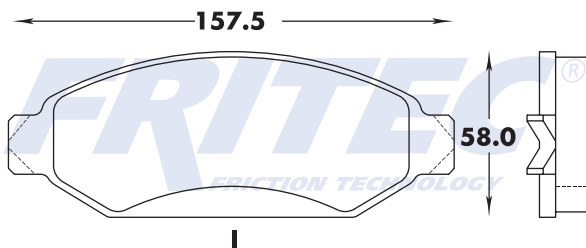

8

793-Z D49

D/F	T/R	E/T
X		14.0

793-Z D49

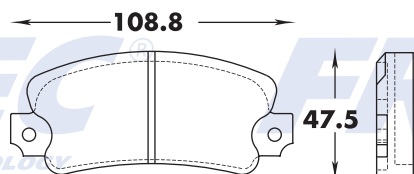

9

794-Z D57

D/F	T/R	E/T
X		15.4

794-Z D57

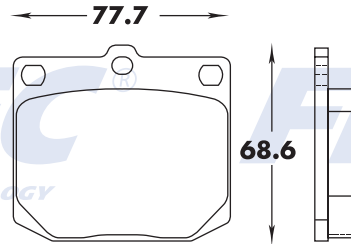

10

795-Z D57

D/F	T/R	E/T
X		15.0

795-Z D57

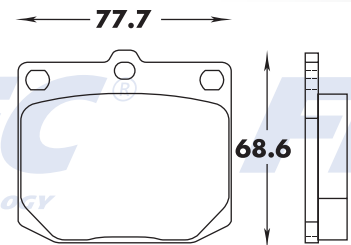

11

795-Z D161

D/F	T/R	E/T
X		15.0

795-Z D161

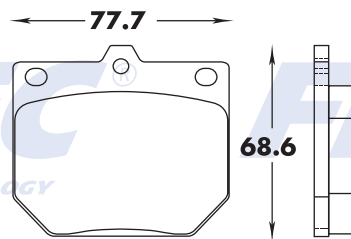

12

7009-Z D76

D/F	T/R	E/T
X		14.0

7009-Z D76

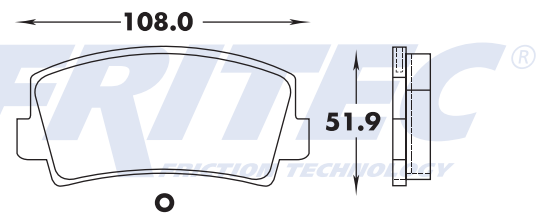
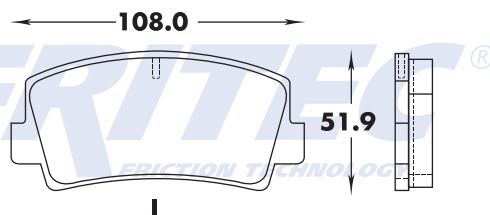

13

7013-Z D50

D/F	T/R	E/T
X		17.1, 14.4

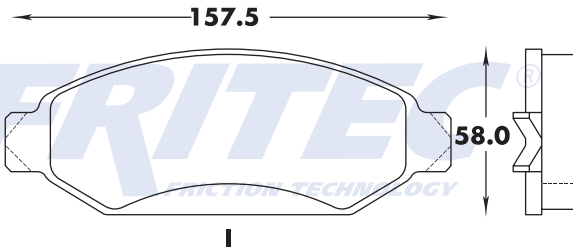

7013-Z D50

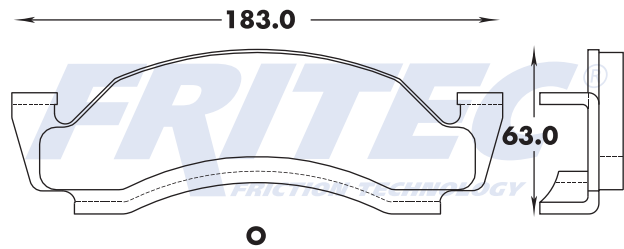

14

7017-Z D84

D/F	T/R	E/T
X		17.7, 13.6

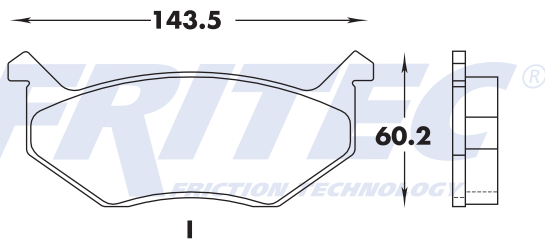

7017-Z D84

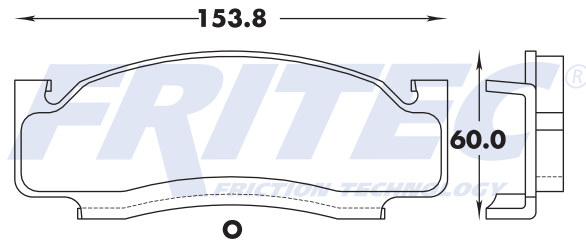

15

7019-Z D86

D/F	T/R	E/T
X		17.7, 13.8

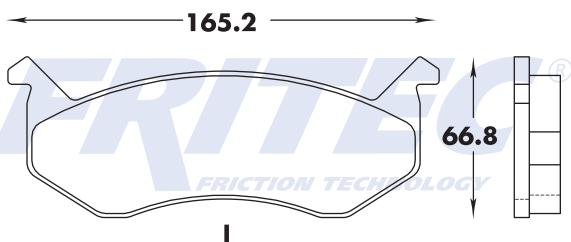

7019-Z D86

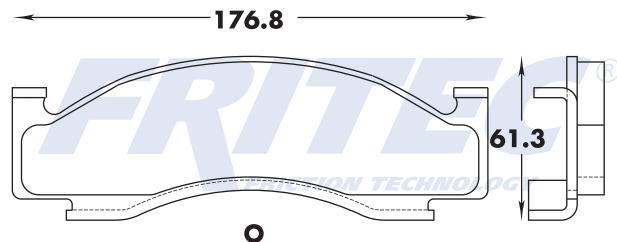

16

7021-Z D45

D/F	T/R	E/T
X		19.1

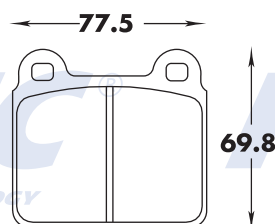

7021-Z D45

17

7027-Z D91

D/F	T/R	E/T
X		15.2, 14.6

7027-Z D91

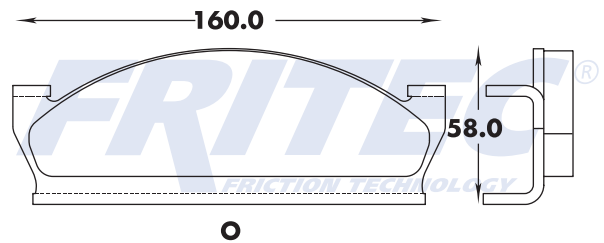
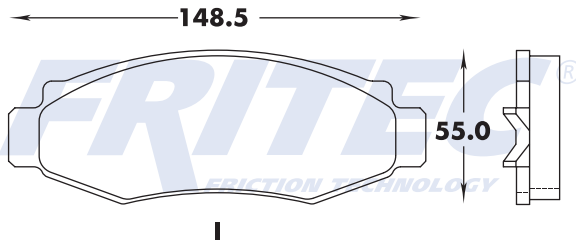

18

7031-Z D96

D/F	T/R	E/T
X		18.4

7031-Z D96

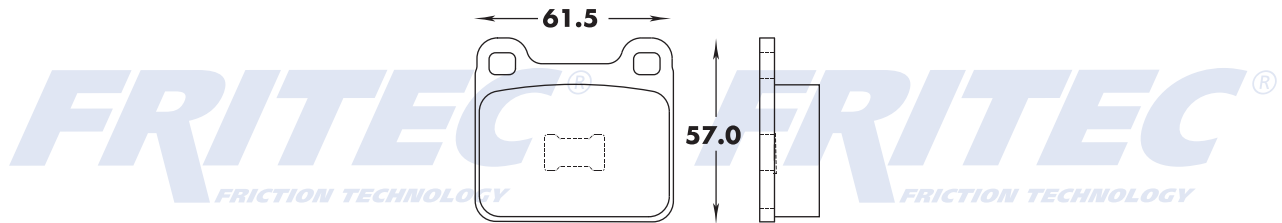

19

7046-Z D113

D/F	T/R	E/T
X		14.2

7046-Z D113

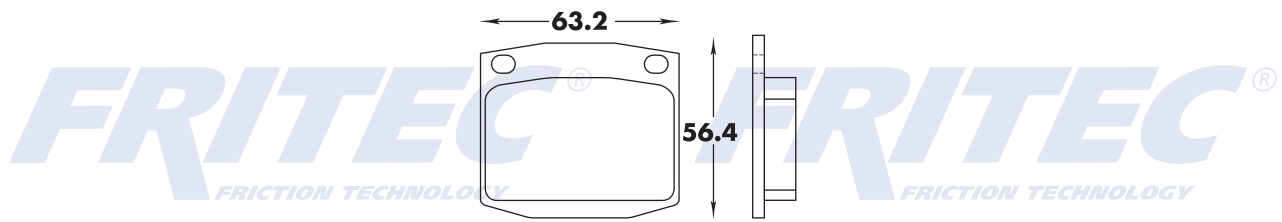

20

7046-Z1 D146

D/F	T/R	E/T
X		14.2

7046-Z1 D146

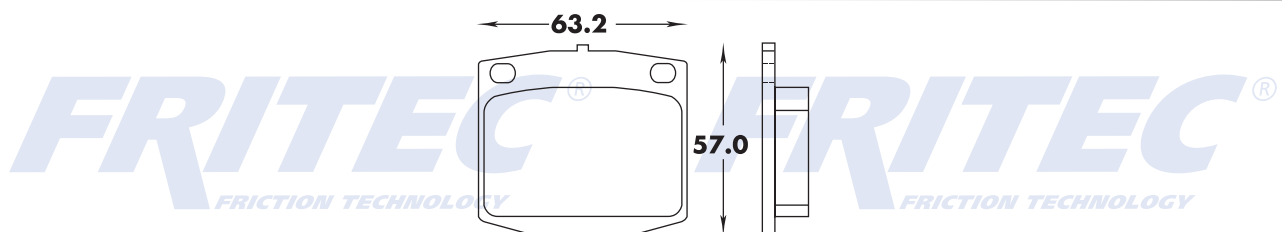

21

7047-Z D114

D/F	T/R	E/T
X		15.2

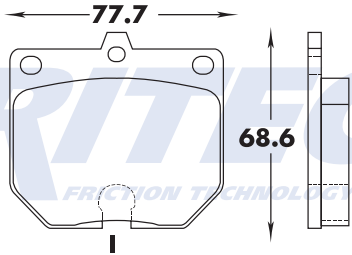

7047-Z D114

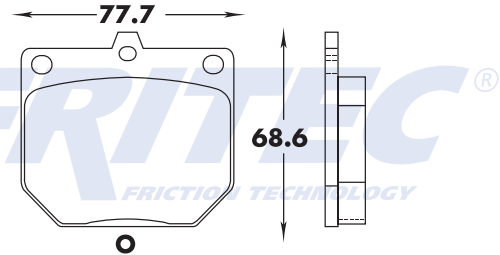

22

7059-Z D41

D/F	T/R	E/T
X		14.5

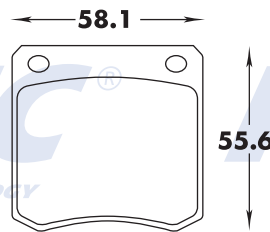

7059-Z D41

23

7069-Z D137

D/F	T/R	E/T
X		15.2

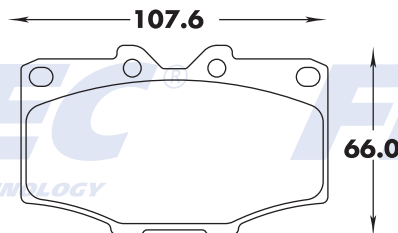

7069-Z D137

24

7070-Z D154

D/F	T/R	E/T
X		15.7, 13.5

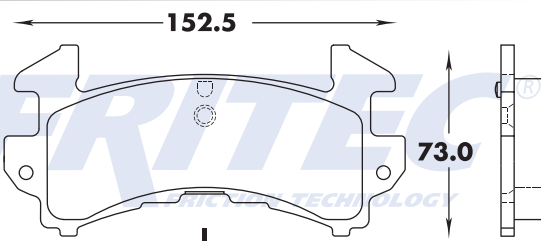

7070-Z D154

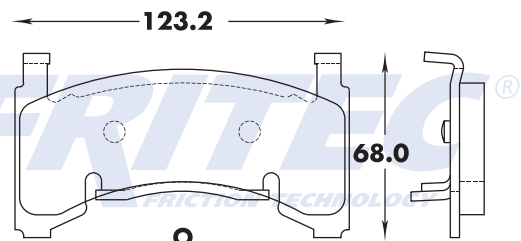

25

7070A-Z1 D154

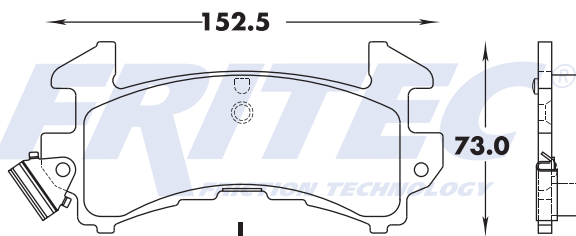

D/F	T/R	E/T
X		15.7, 13.5

7070A-Z1 D154

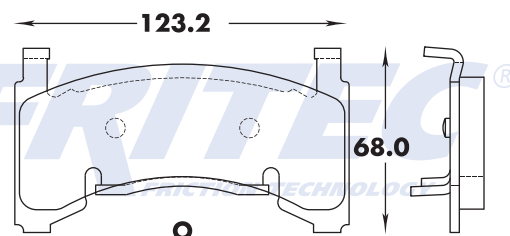

26

7070-CZ D183

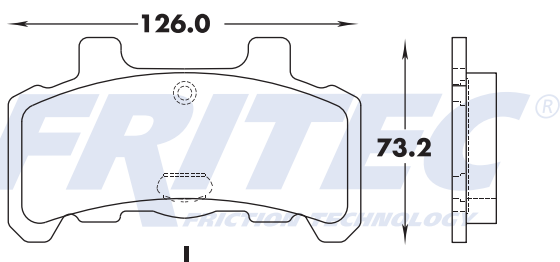

D/F	T/R	E/T
X		15.7, 13.5

7070-CZ D183

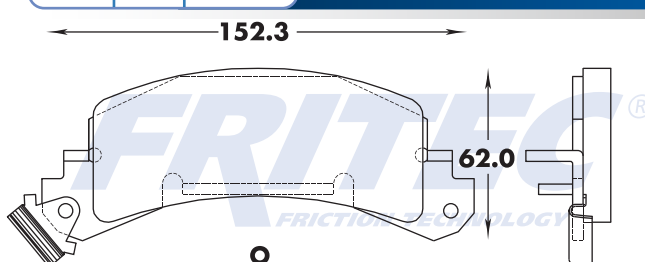

27

7072-AZ1 D152

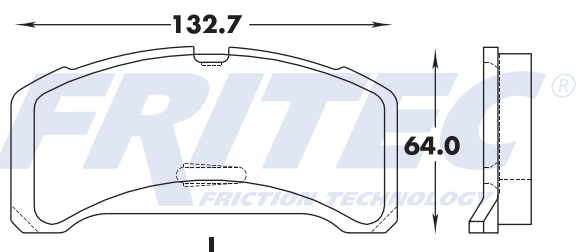

D/F	T/R	E/T
X		16.4, 14.6

7072-AZ1 D152

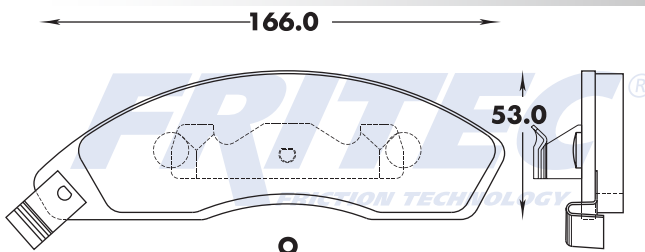

28

7072-Z D181

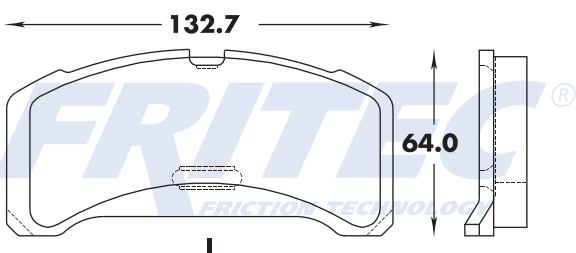

D/F	T/R	E/T
X		16.4, 14.6

7072-Z D181

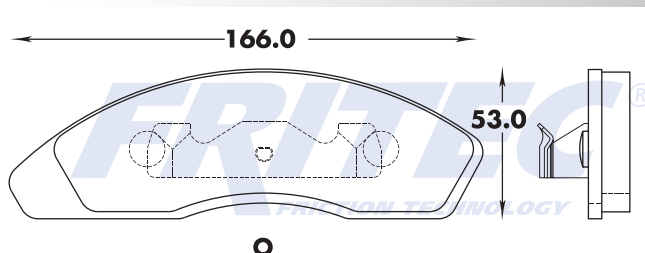

29

7072-BZ D310

D/F	T/R	E/T
X		16.4, 14.6

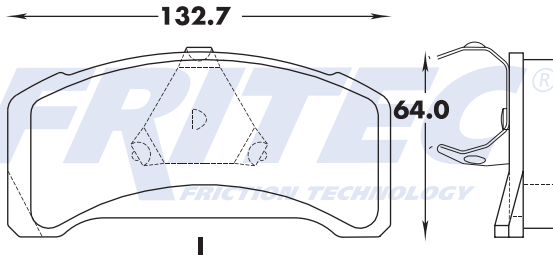

7072-BZ D310

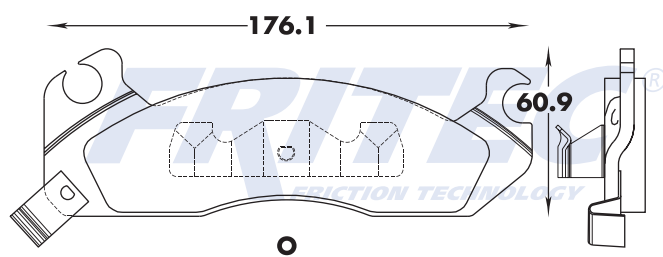

30

7081-Z D149

D/F	T/R	E/T
X		20.1, 15.8

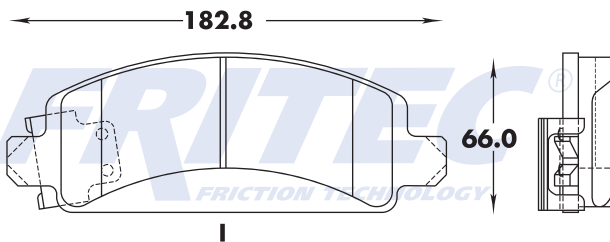

7081-Z D149

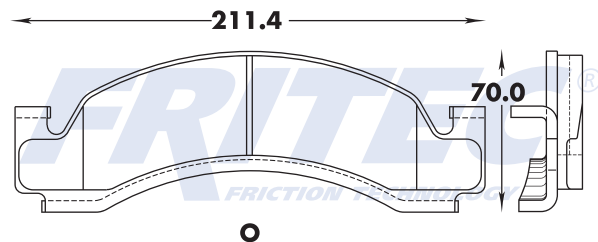

31

7082-AZ D150

D/F	T/R	E/T
X		17.1, 15.2

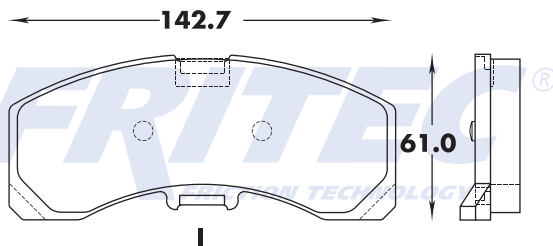

7082-AZ D150

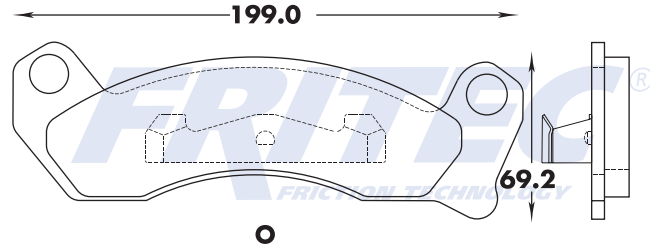

32

7082-Z D199

D/F	T/R	E/T
X		17.1, 15.2

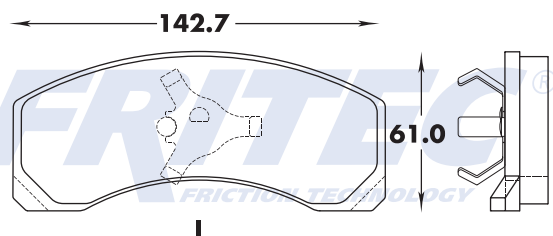

7082-Z D199

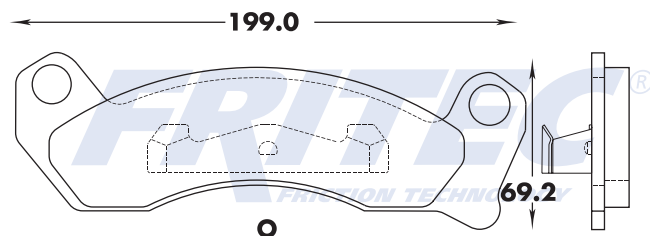

33

7084-Z D153

D/F	T/R	E/T
X		17.4, 13.5

7084-Z D153

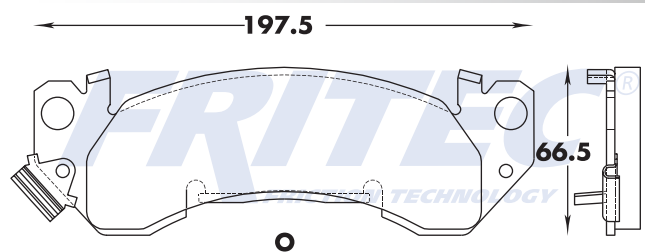
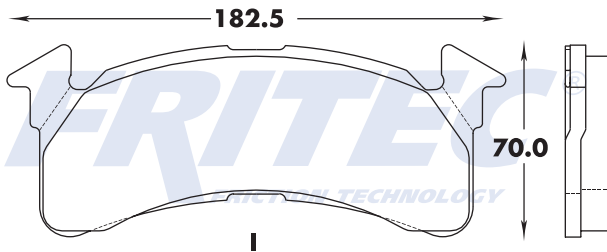

34

7097-Z D170

D/F	T/R	E/T
X		17.5

7097-Z D170

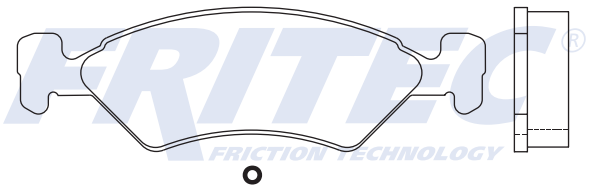
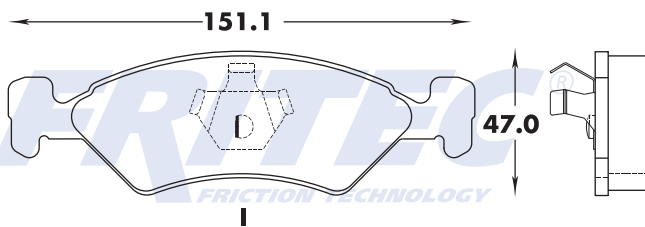

35

7106-Z D179

D/F	T/R	E/T
X		17.1

7106-Z D179

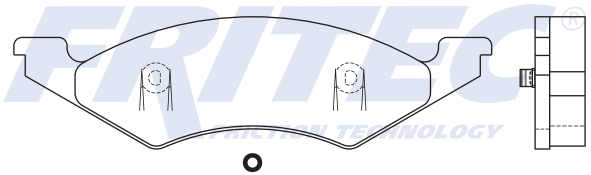
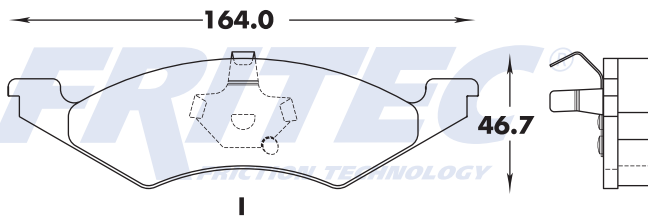

36

7106-Z1 D257

D/F	T/R	E/T
X		17.1

7106-Z1 D257

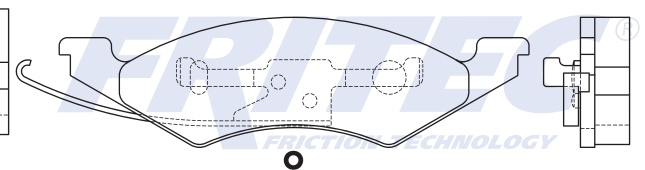
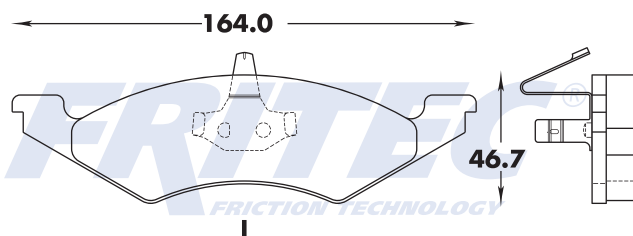

37

7122-Z D203

D/F	T/R	E/T
X		16.1, 16.1

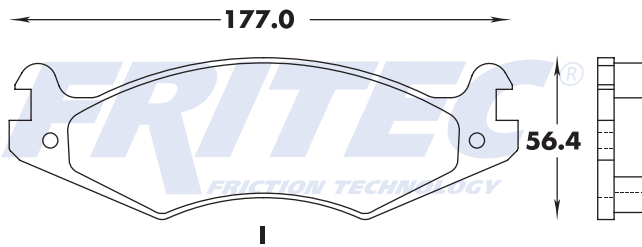

7072-BZ D310

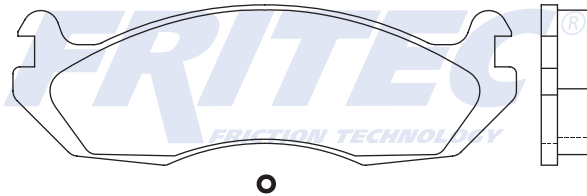

38

7125-Z D205

D/F	T/R	E/T
X		15.4, 14.4

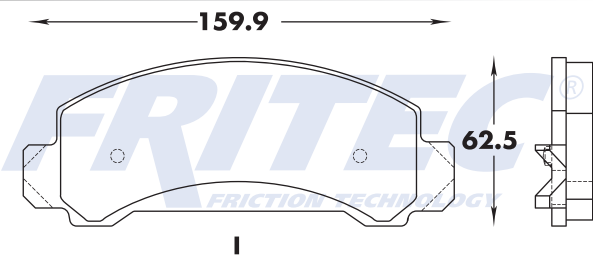

7125-Z D205

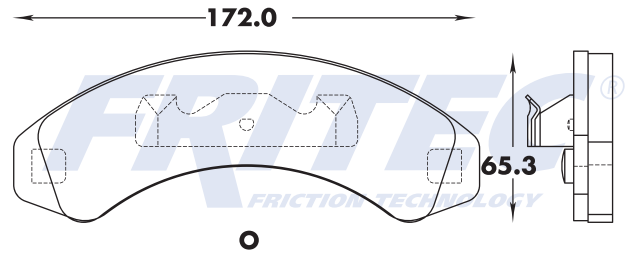

39

7125-Z1 D249

D/F	T/R	E/T
X		15.1, 14.4

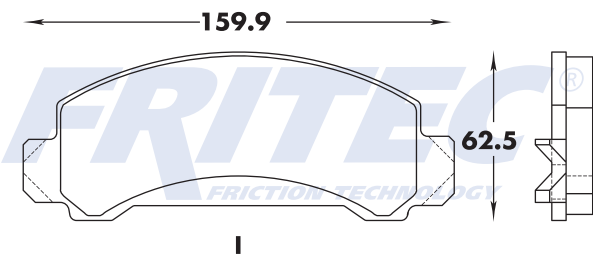

7125-Z1 D249

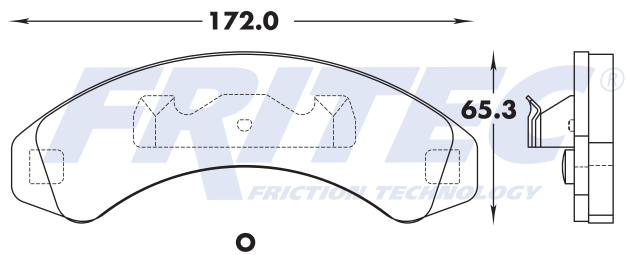

40

7125-AZ D387

D/F	T/R	E/T
X		15.1, 14.4

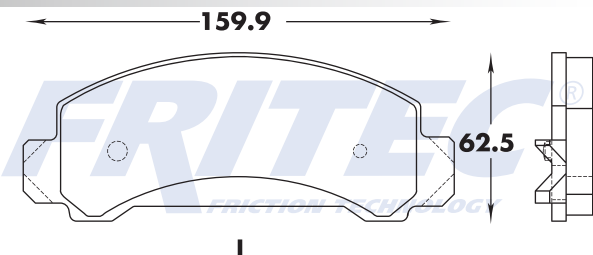

7125-AZ D387

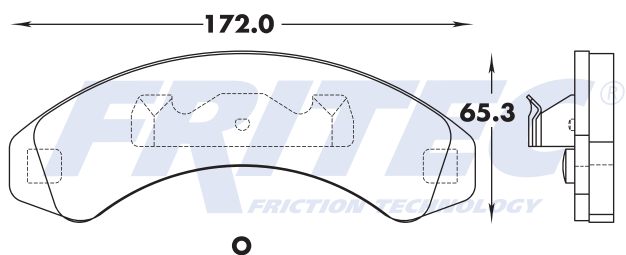

41

7127-Z D207

D/F	T/R	E/T
X		15.4

7127-Z D207

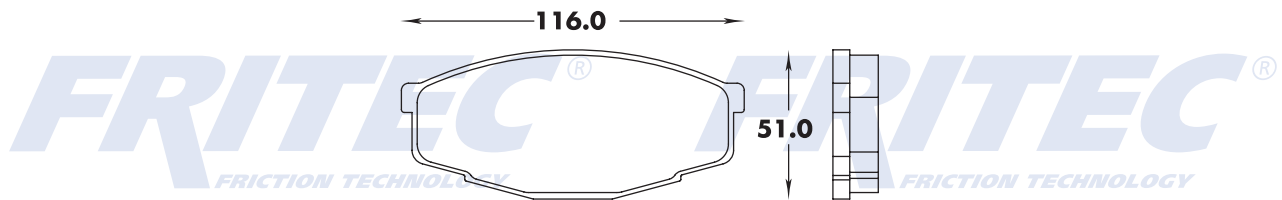

42

7134-Z D220

D/F	T/R	E/T
X		16.1

7134-Z D220

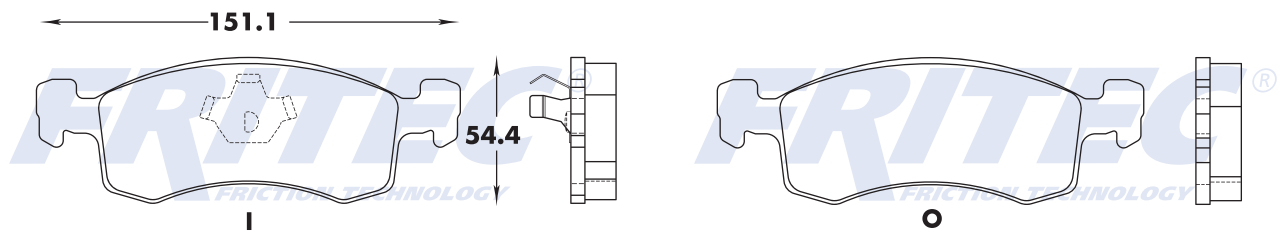

43

7136-Z D215

D/F	T/R	E/T
X		16.0, 11.6

7136-Z D215

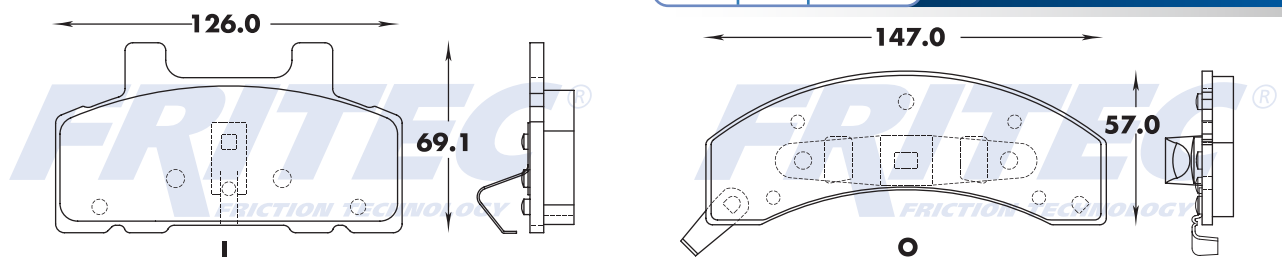

44

7143-Z D227

D/F	T/R	E/T
X		19.2

7143-Z D227

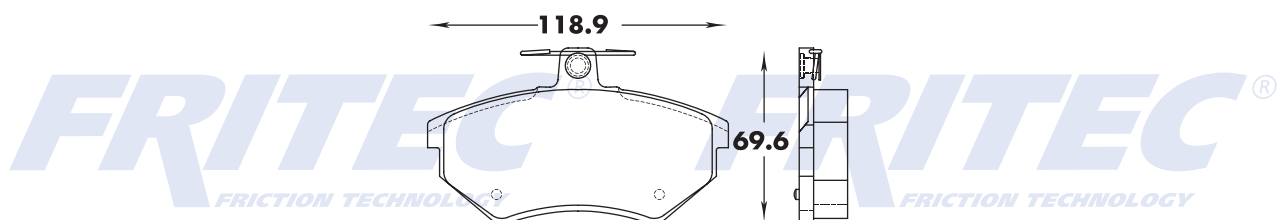

45

7144-Z D228

D/F	T/R	E/T
X		16.1

7144-Z D228

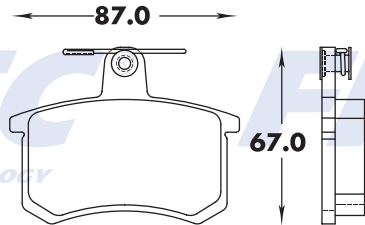

46

7153-Z D242

D/F	T/R	E/T
X		15.0

7153-Z D242

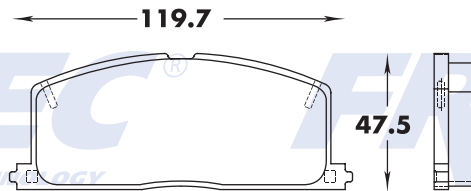

47

7155-Z D233

D/F	T/R	E/T
X		15.6

7155-Z D233

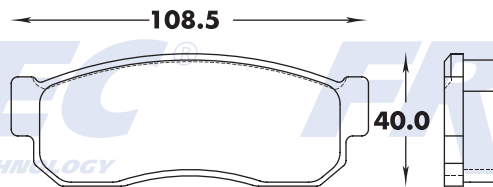

48

7155-Z1 D275

D/F	T/R	E/T
X		15.6

7155-Z1 D275

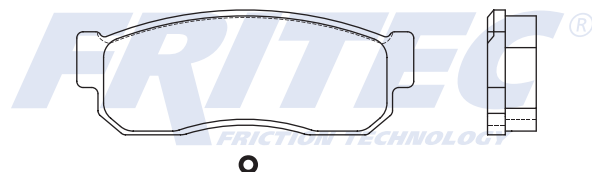
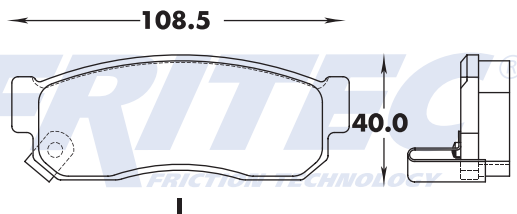

49

7164-Z D259

D/F	T/R	E/T
X		19.6, 18.5

7164-Z D259

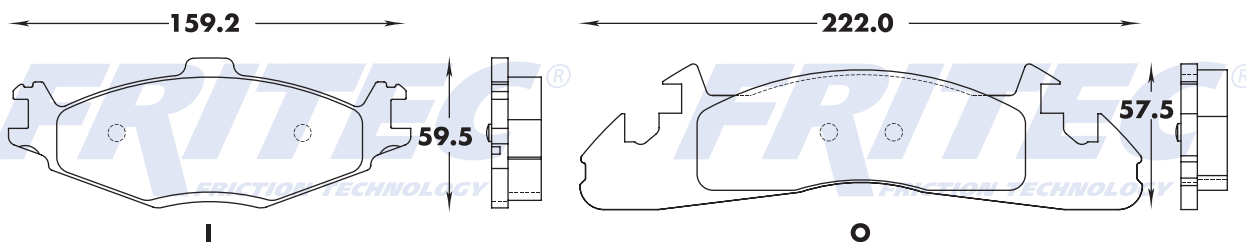

50

7170-Z D265

D/F	T/R	E/T
X		16.8

7170-Z D265

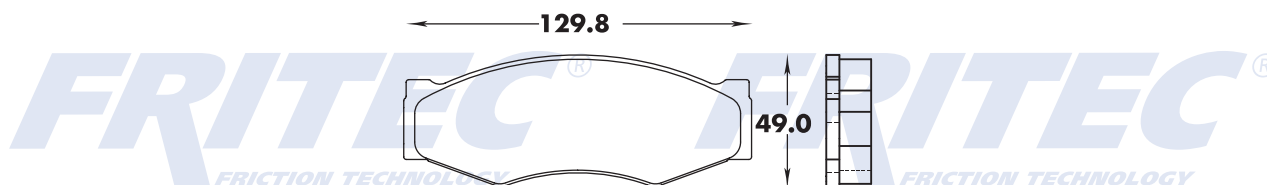

51

7171-Z D266

D/F	T/R	E/T
X		16.8

7171-Z D266

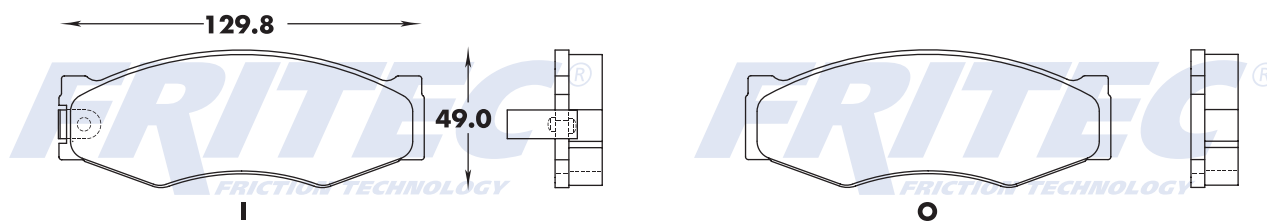

52

7178-Z D273

D/F	T/R	E/T
X		14.9

7178-Z D273

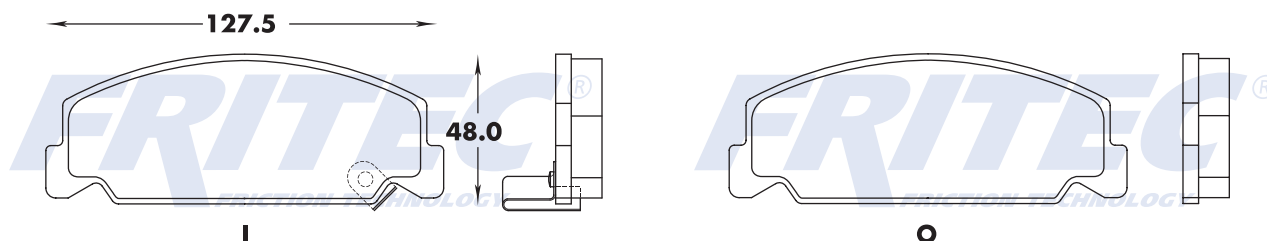

53

7179-AZ D269

D/F	T/R	E/T
X		17.3, 12.7

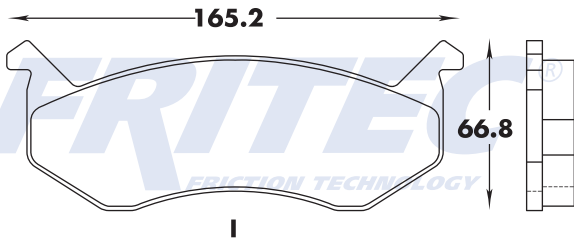

7179-AZ D269

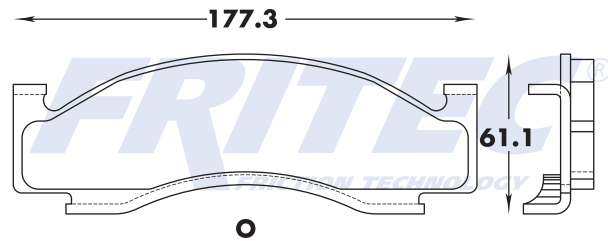

54

7183-Z F111

D/F	T/R	E/T
X		19.8, 18.0

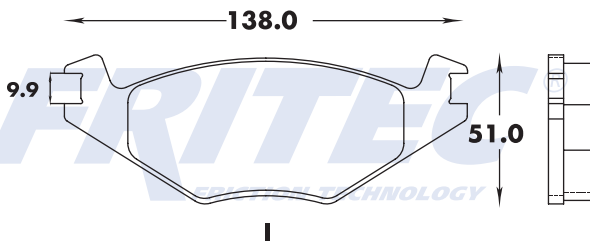

7183-Z F111

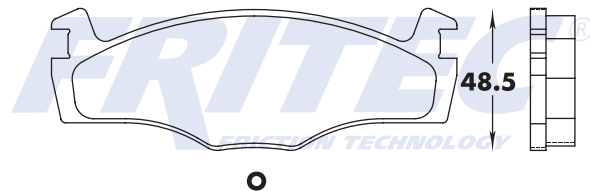

55

7183-Z1 D280

D/F	T/R	E/T
X		15.2

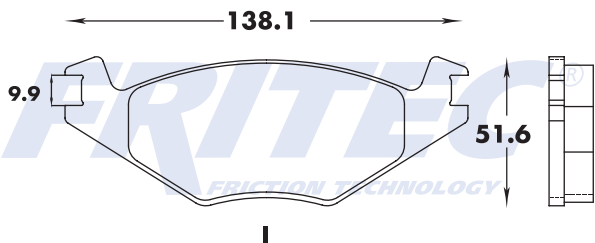

7183-Z1 D280

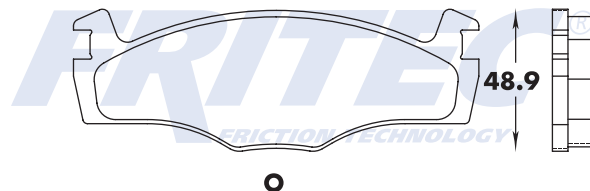

56

7183-Z2 D569

D/F	T/R	E/T
X		15.1

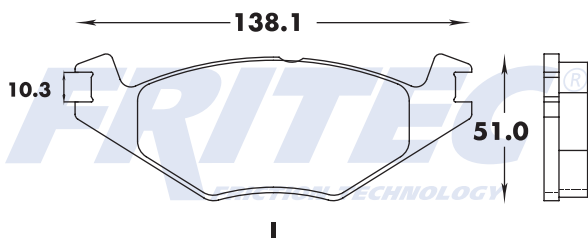

7183-Z2 D569

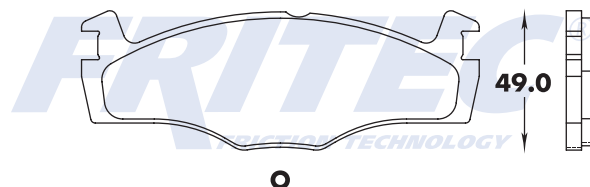

57

7186-Z1 D332

D/F	T/R	E/T
X		13.1

7186-Z1 D332

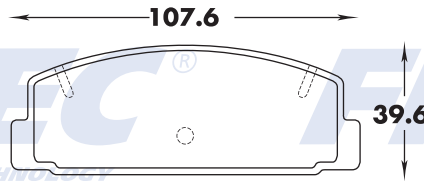

58

7188-Z D285

D/F	T/R	E/T
X		15.2

7188-Z D285

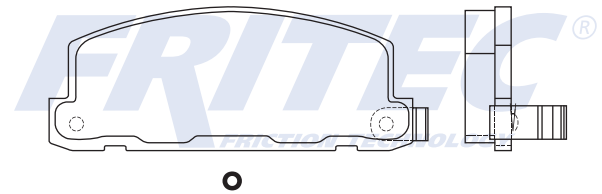
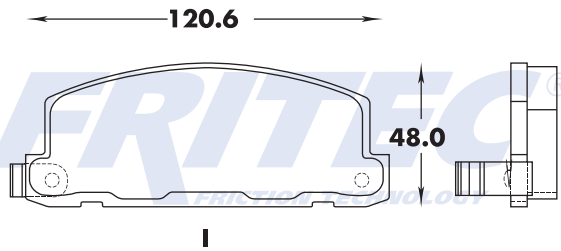

59

7192-Z D289

D/F	T/R	E/T
X		16.0, 10.3

7192-Z D289

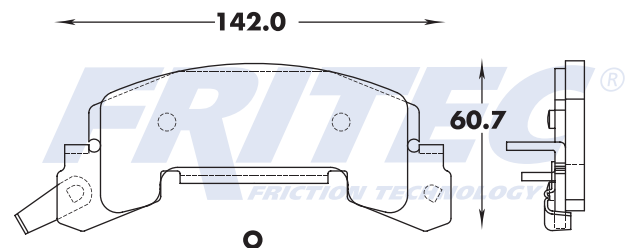
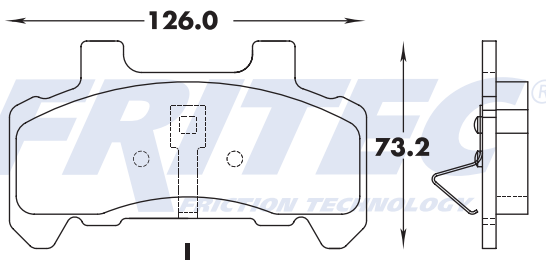

60

71X4-Z F051

D/F	T/R	E/T
X		17.4

71X4-Z F051

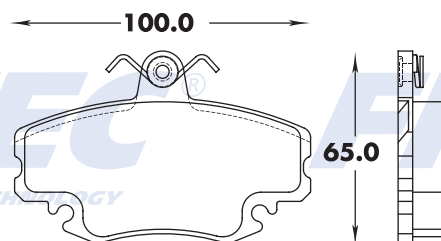

61

8256-D1146

D/F	T/R	E/T
X		17.4

8256-D1146

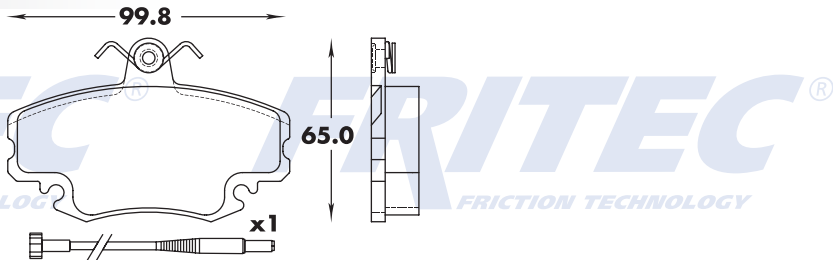

62

71X5-Z F013

D/F	T/R	E/T
X		15.0

71X5-Z F013

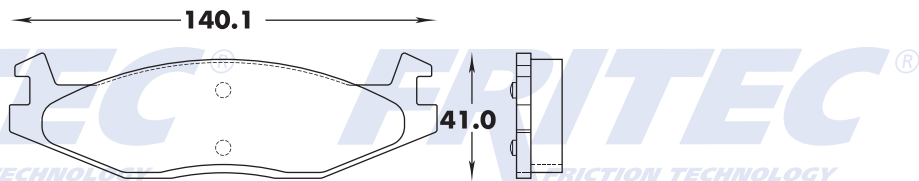

63

71Y4-Z F450

D/F	T/R	E/T
X		16.3

71Y4-Z F450

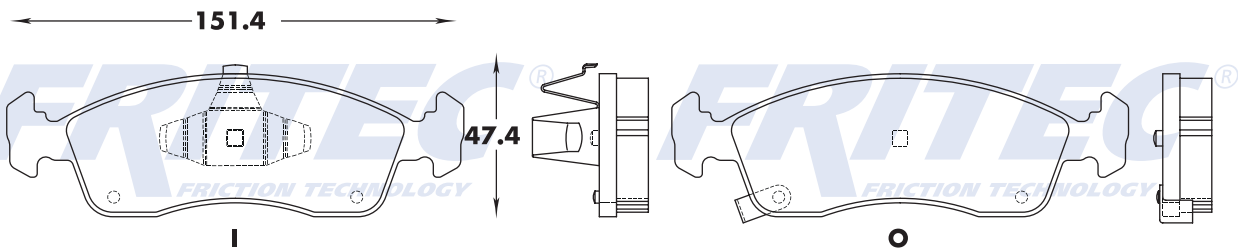

64

7205-Z D303

D/F	T/R	E/T
X		15.5

7205-Z D303

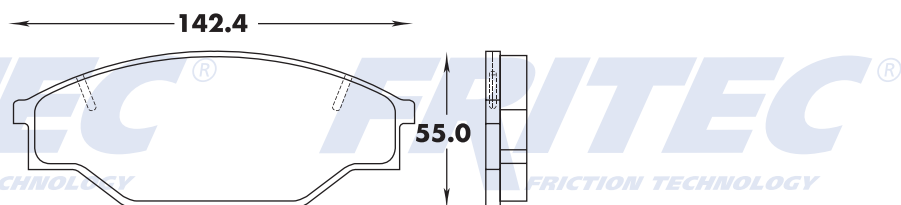

65

7209-Z D280

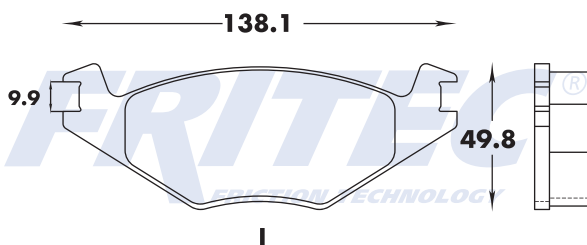

D/F	T/R	E/T
X		19.4

7209-Z D280

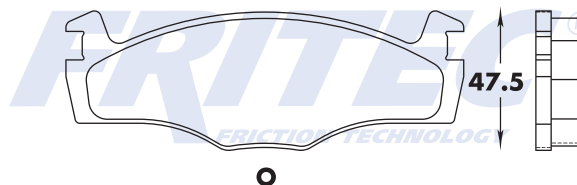

66

7209-Z1 D569

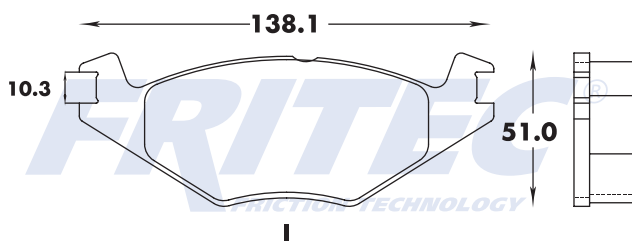

D/F	T/R	E/T
X		19.4

7209-Z1 D569

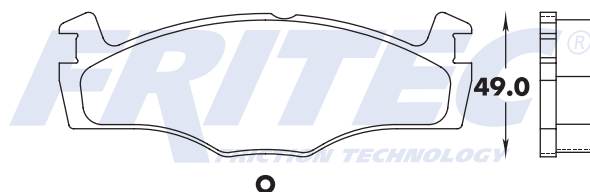

67

7219-Z D319

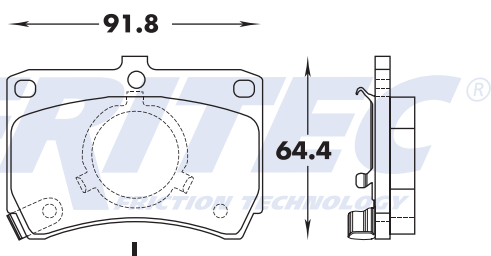

D/F	T/R	E/T
X		14.9

7219-Z D319

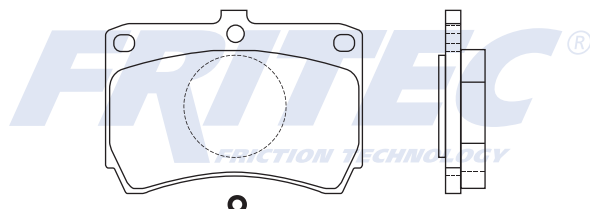

68

7219-Z1 D466

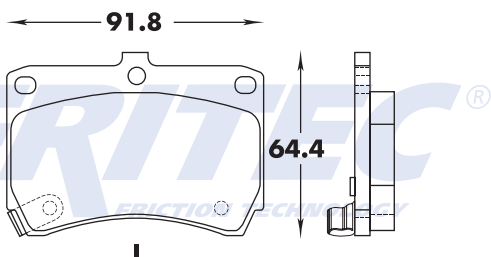

D/F	T/R	E/T
X		14.9

7219-Z1 D466

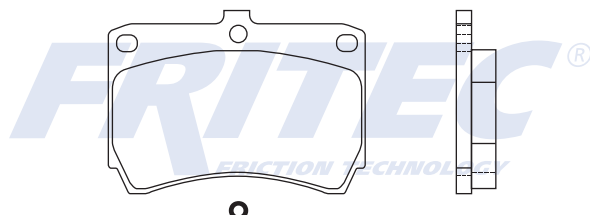

69

7220-Z D320

D/F	T/R	E/T
X		15.2

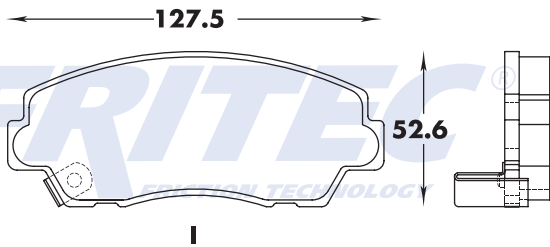

7220-Z D320

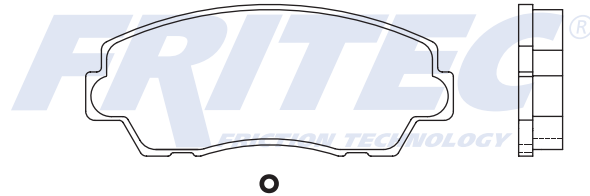

70

7222-Z D324

D/F	T/R	E/T
X		16.6

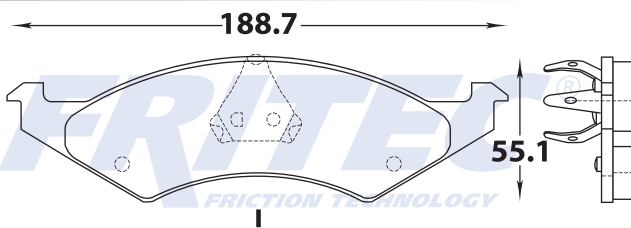

7222-Z D324

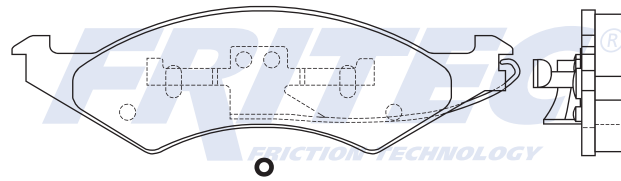

71

7224-Z D326

D/F	T/R	E/T
X		15.2, 14.4

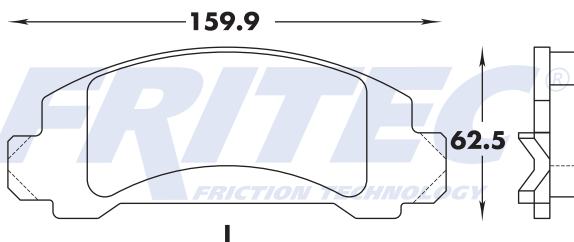

7224-Z D326

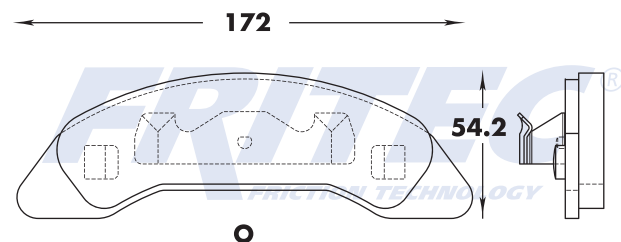

72

7228-Z D333

D/F	T/R	E/T
X		17.0

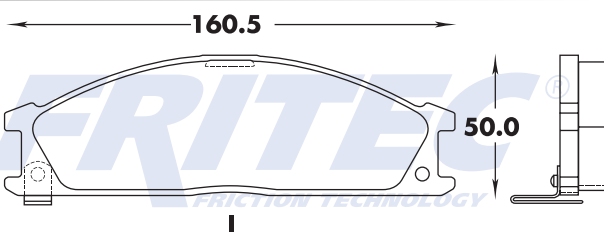

7228-Z D333

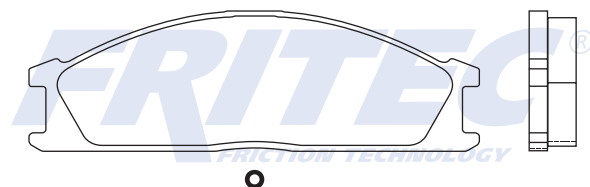

73

7229-Z D334

D/F	T/R	E/T
X		14.9

7229-Z D334

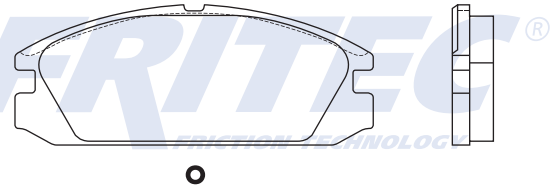
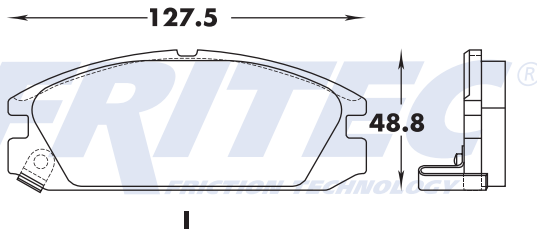

74

7234-Z D340

D/F	T/R	E/T
X		14.9

7234-Z D340

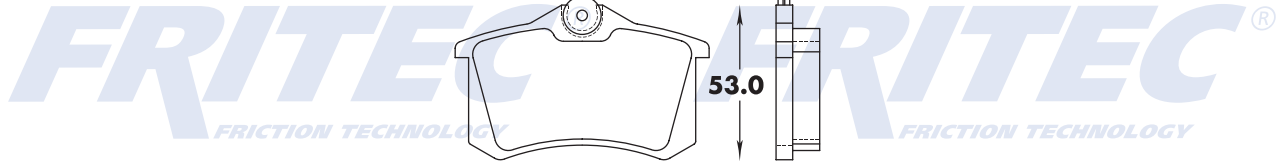
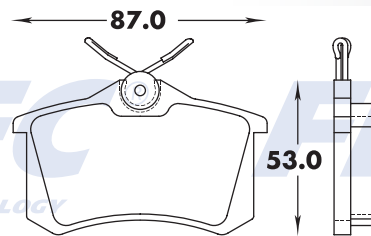

75

7237-AZ D344

D/F	T/R	E/T
X		17.8, 17.1

7237-AZ D344

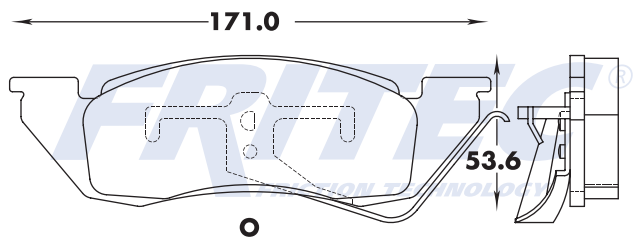
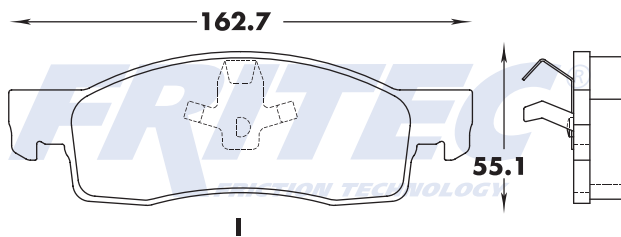

76

723X-Z F027

D/F	T/R	E/T
X		19.1

723X-Z F027

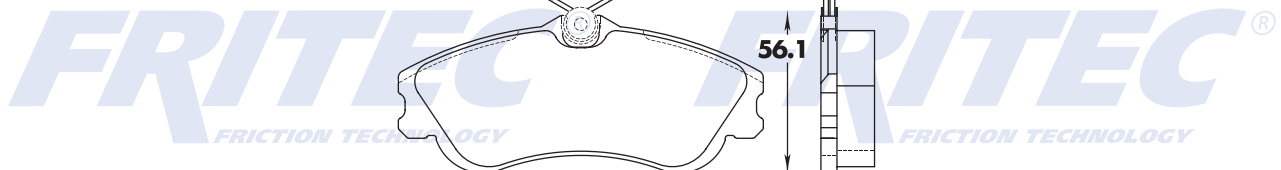
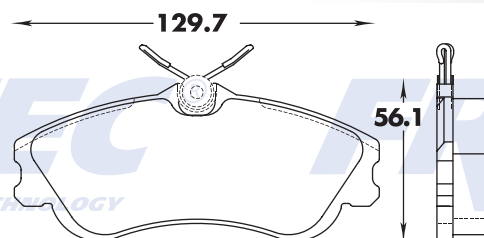

77

8309-D1190

D/F	T/R	E/T
X		19.1

8309-D1190

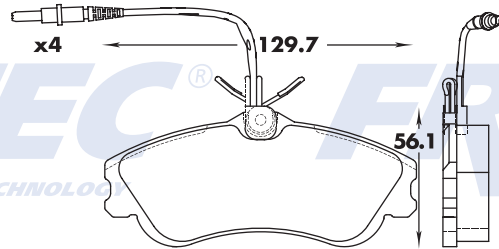

78

7241-Z D349

D/F	T/R	E/T
X		16.3

7241-Z D349

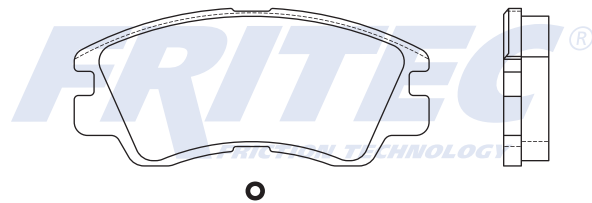
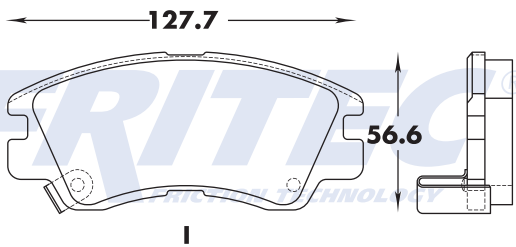

79

7242-Z D350

D/F	T/R	E/T
X		18.8

7242-Z D350

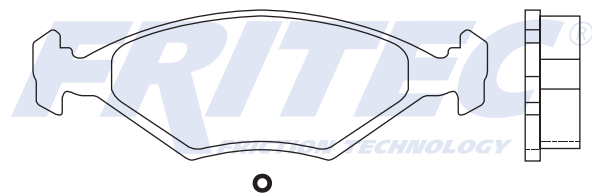
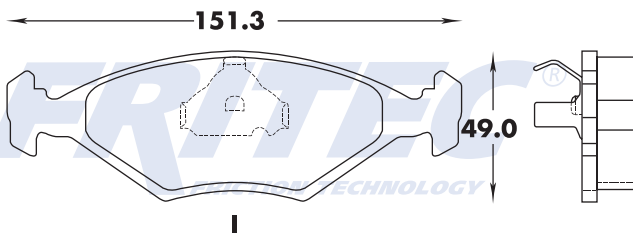

80

7247-Z D356

D/F	T/R	E/T
X		15.1

7247-Z D356

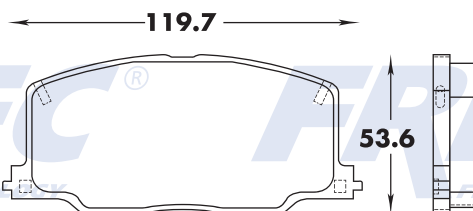

81

7253-Z D363

D/F	T/R	E/T
X		16.4

7253-Z D363

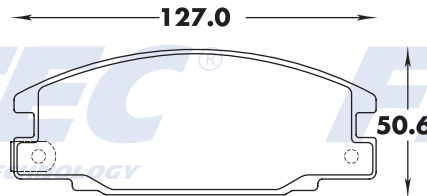

82

7259-Z D368

D/F	T/R	E/T
X		16.6, 15.7

7259-Z D368

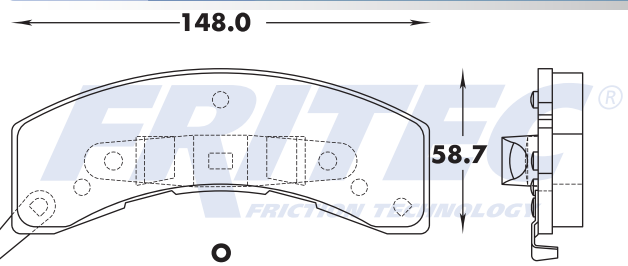
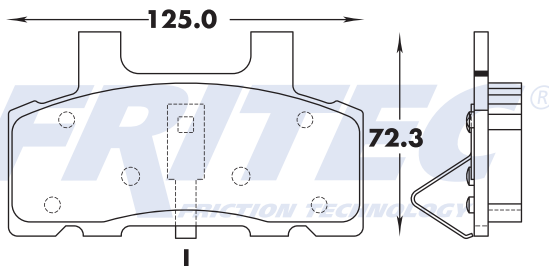

83

7259-Z1 D369

D/F	T/R	E/T
X		16.6, 15.7

7259-Z1 D369

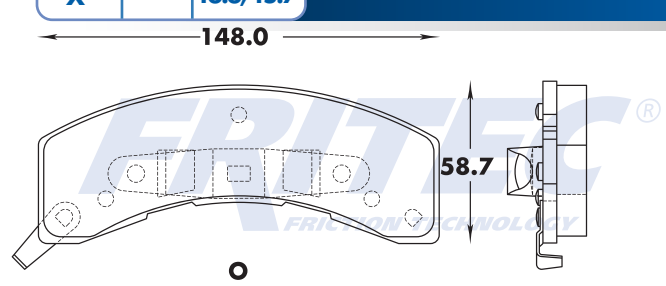
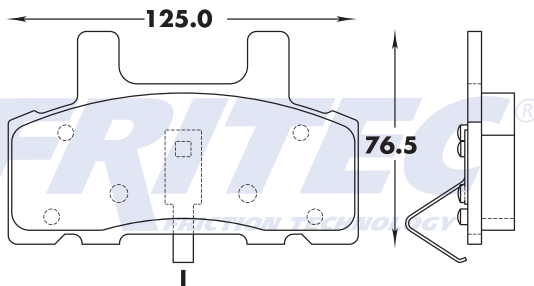

84

7260-Z D370

D/F	T/R	E/T
X		17.0, 15.7

7260-Z D370

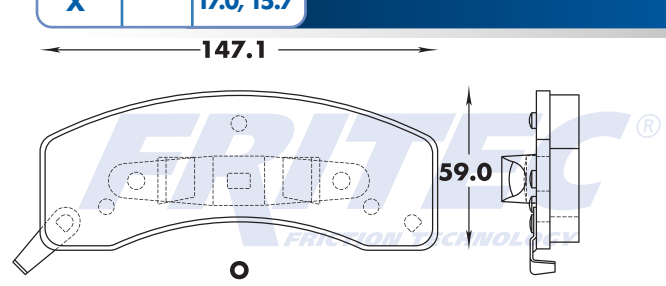
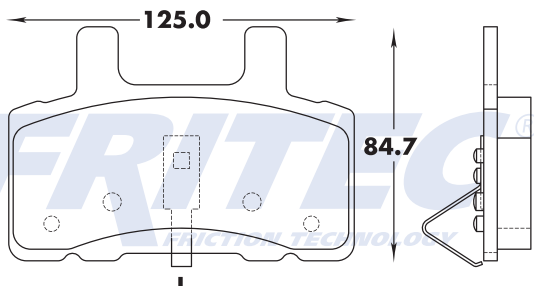

85

7260A-Z D370MA

D/F	T/R	E/T
X		17.0, 15.7

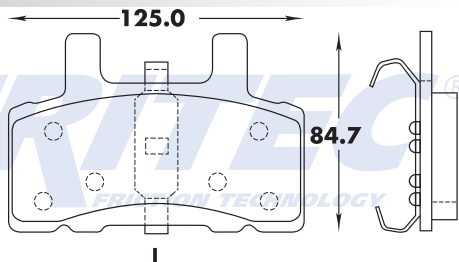

7260A-Z D370MA

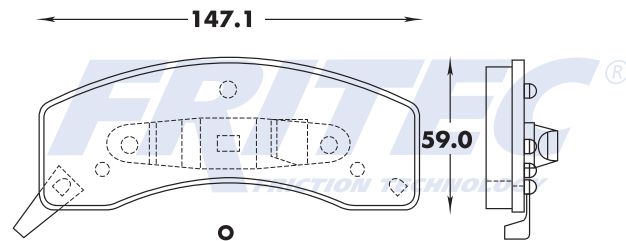

86

7264-Z D375

D/F	T/R	E/T
X		16.1, 14.0

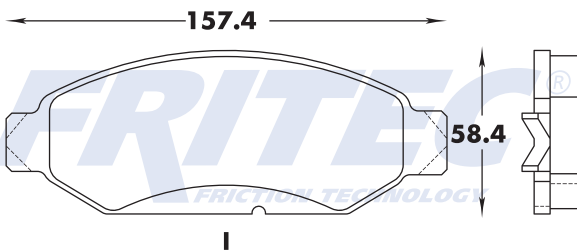

7264-Z D375

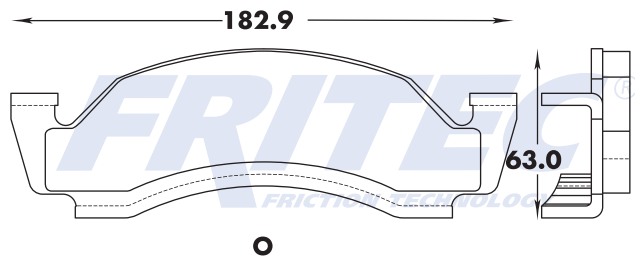

87

7265-Z D376

D/F	T/R	E/T
X		17.3

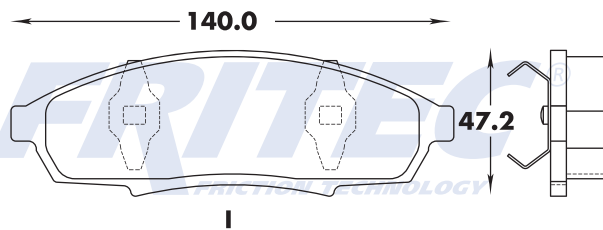

7265-Z D376

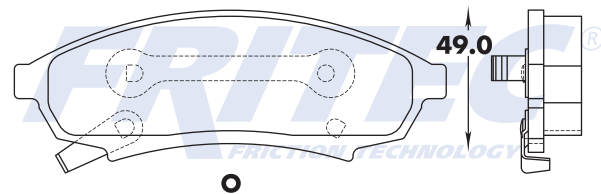

88

7267-Z D378

D/F	T/R	E/T
X		14.1

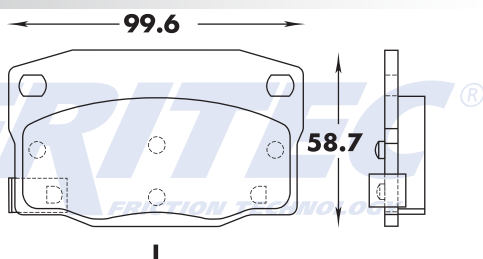

7267-Z D378

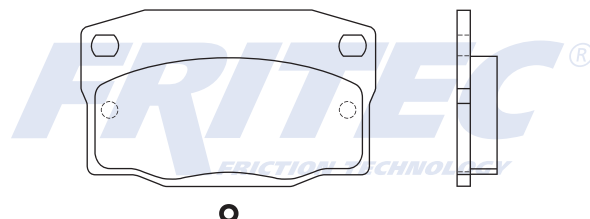

89

7272-Z D383

D/F	T/R	E/T
X		15.4

7272-Z D383

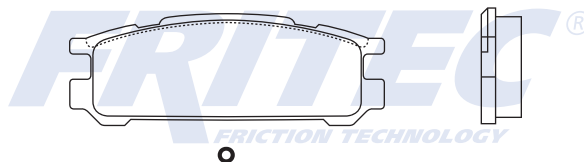
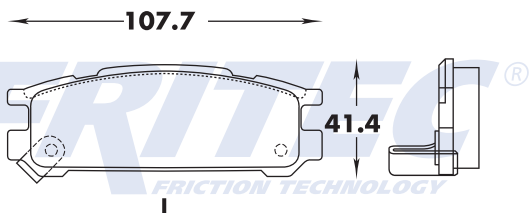

90

7286-Z D396

D/F	T/R	E/T
X		16.3

7286-Z D396

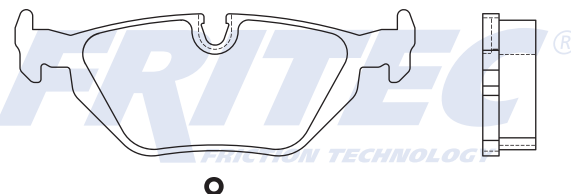
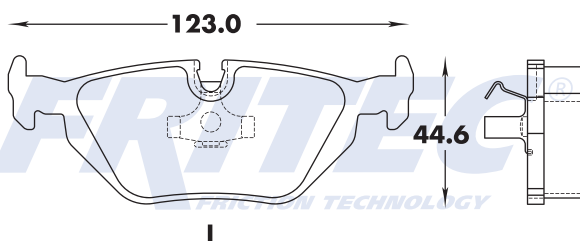

91

7286-Z3 D1267

D/F	T/R	E/T
X		16.9

7286-Z3 D1267

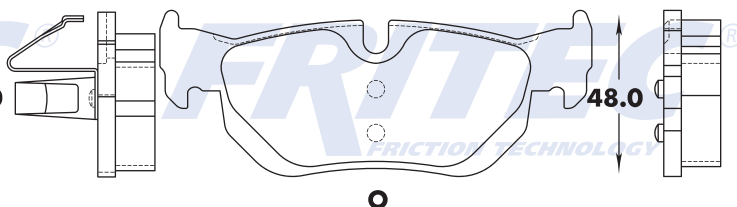
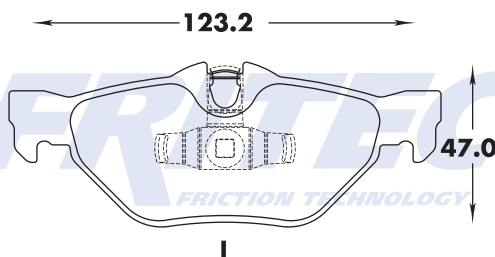

92

7290-Z D401

D/F	T/R	E/T
X		15.7

7290-Z D401

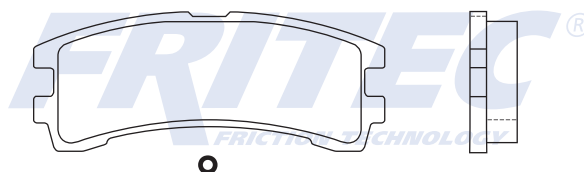
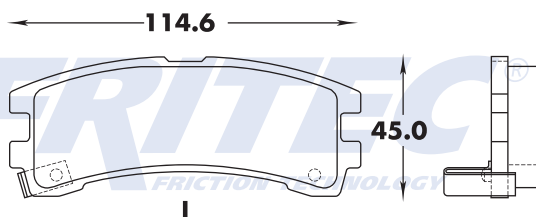

93

7293-Z D404

D/F	T/R	E/T
X		14.7

7293-Z D404

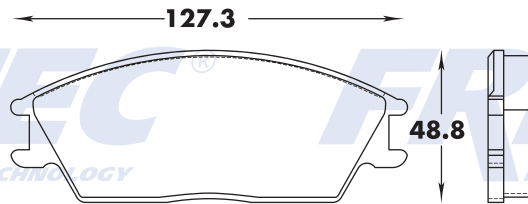

94

7298-Z D410

D/F	T/R	E/T
X		15.0

7298-Z D410

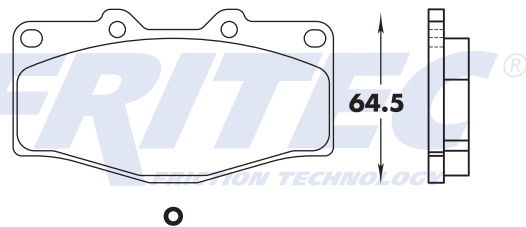
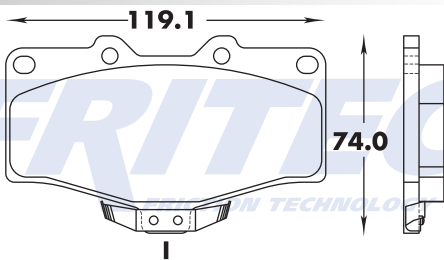

95

7298-Z1 D436

D/F	T/R	E/T
X		15.0

7298-Z1 D436

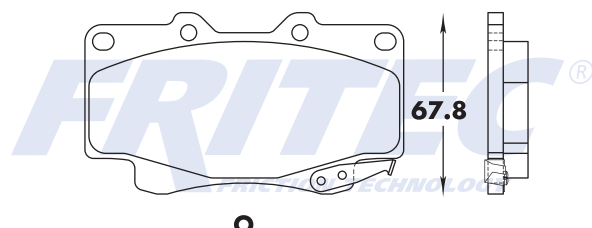
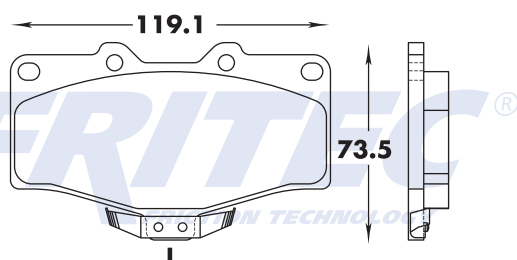
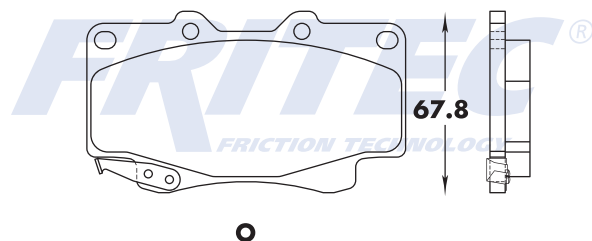
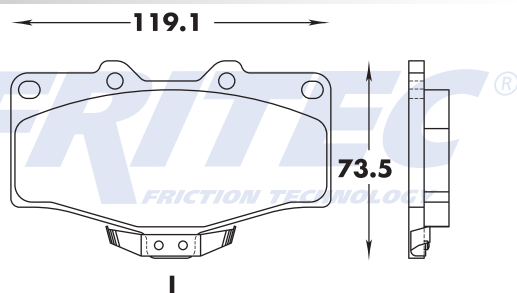

7298-Z3 D611

D/F	T/R	E/T
X		15.4

7298-Z3 D611

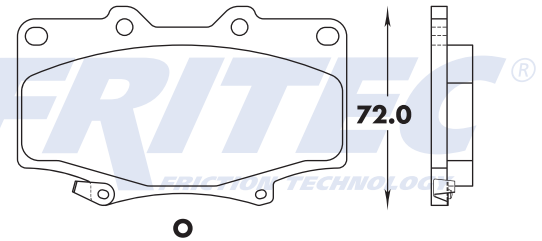
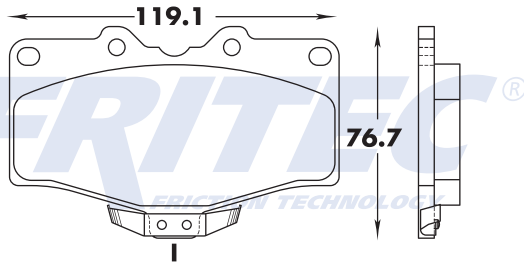

7299-Z D411

D/F	T/R	E/T
X		20.7

7299-Z D411

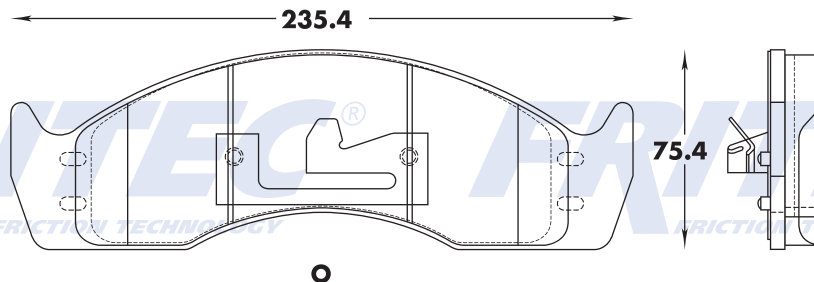
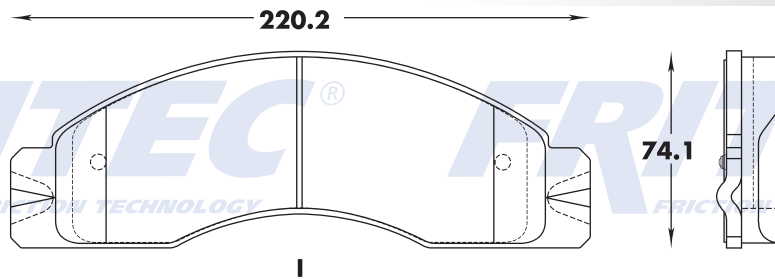

8983-D1755

D/F	T/R	E/T
X		17.0

8983-D1755

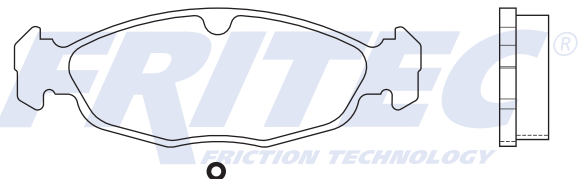
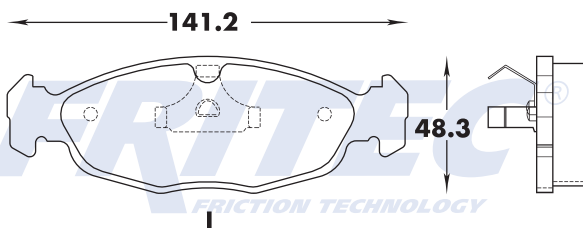

99

72X9-Z D569

D/F	T/R	E/T
X		14.2

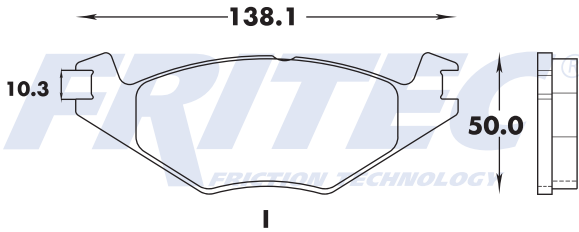

72X9-Z D569

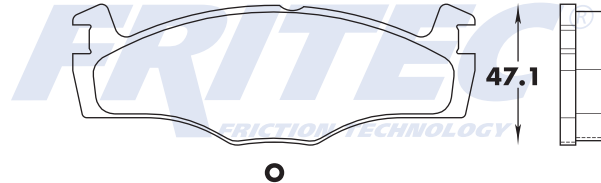

100

7300-Z D412

D/F	T/R	E/T
X		15.4

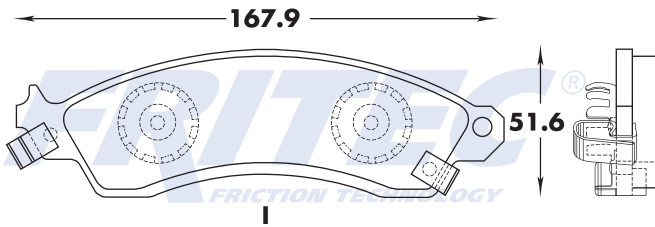

7300-Z D412

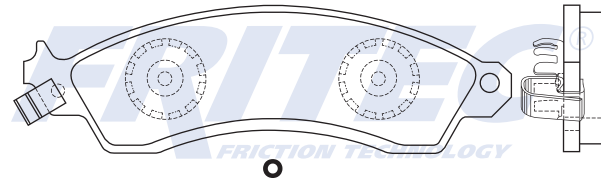

101

7303-Z D415

D/F	T/R	E/T
X		15.7

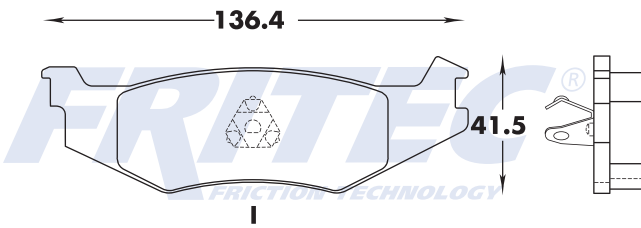

7303-Z D415

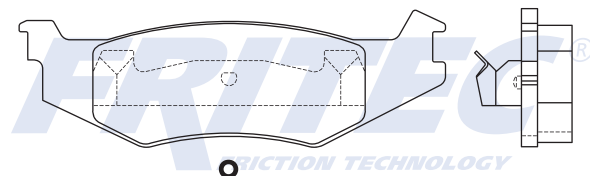
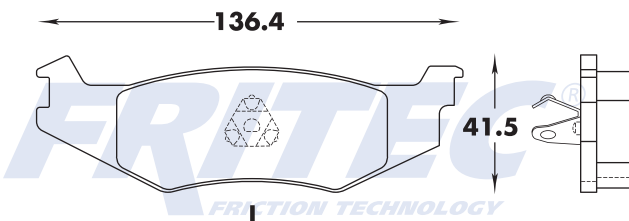
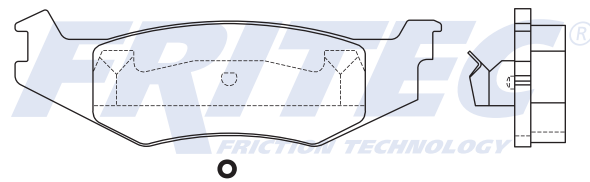

7303-Z1 D512

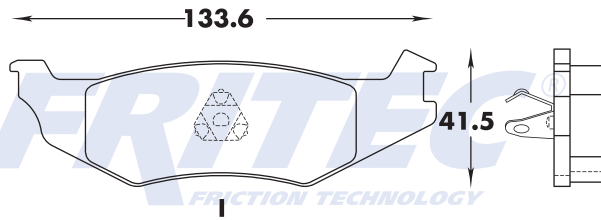

D/F	T/R	E/T
X		15.4

7303-Z1 D512

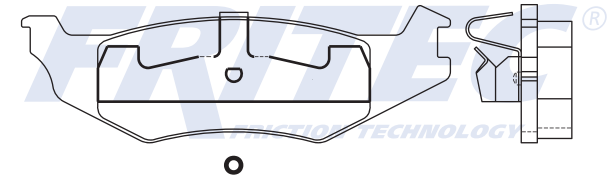
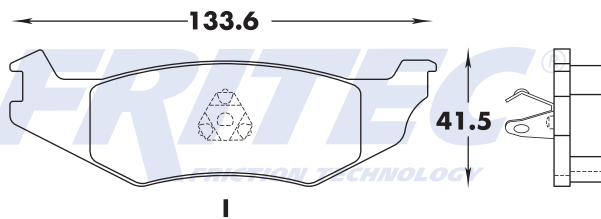
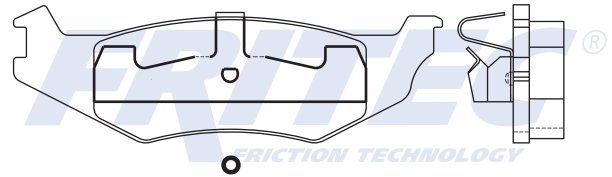

7304-Z D417

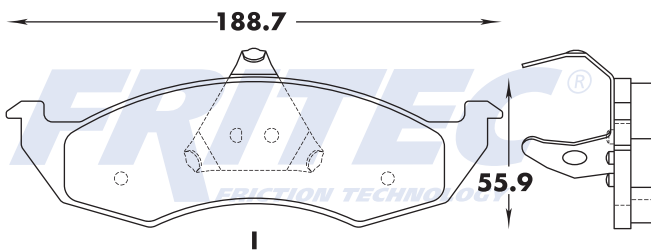

D/F	T/R	E/T
X		15.7

7304-Z D417

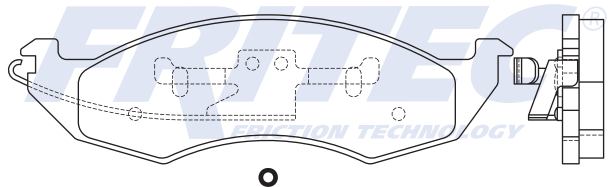

7305-Z D418

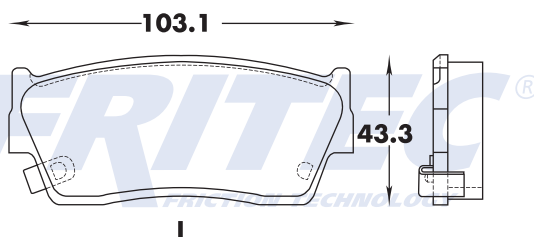

D/F	T/R	E/T
X		14.9

7305-Z D418

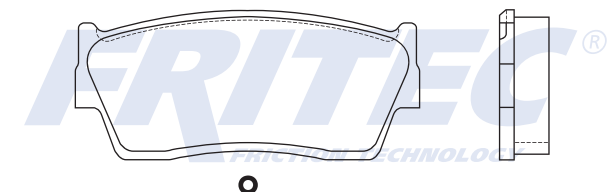

105

7308-AZ D421MA

D/F	T/R	E/T
X		15.7

7308-AZ D421MA

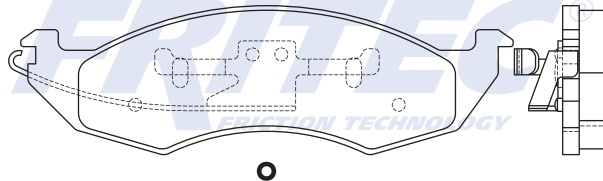
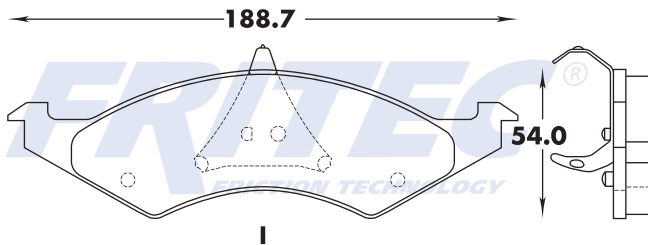

106

7310-Z D420

D/F	T/R	E/T
X		14.9

7310-Z D420

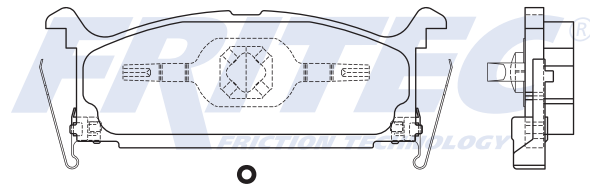
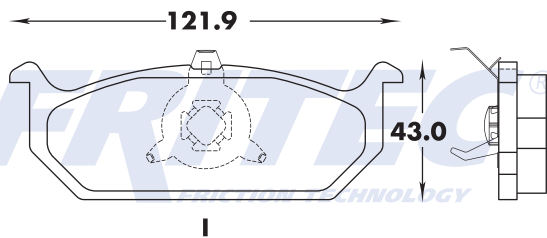

107

7318-Z D430

D/F	T/R	E/T
X		17.0

7318-Z D430

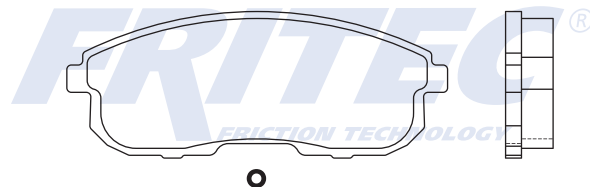
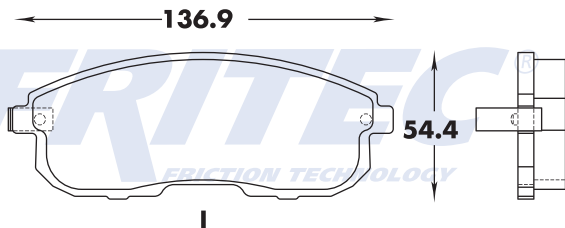

108

7318-Z1 D653

D/F	T/R	E/T
X		17.0

7318-Z1 D653

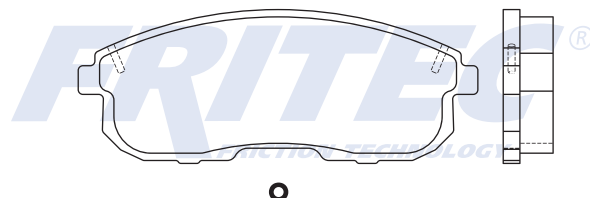
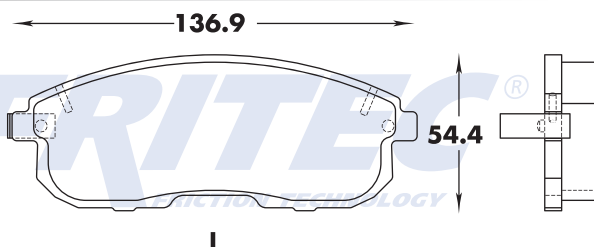

109

7318-Z2 D815

D/F	T/R	E/T
X		17.0

7318-Z2 D815

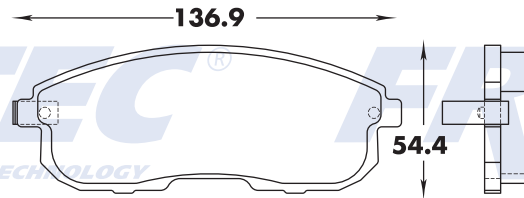

110

7320-Z D433

D/F	T/R	E/T
X		15.2

7320-Z D433

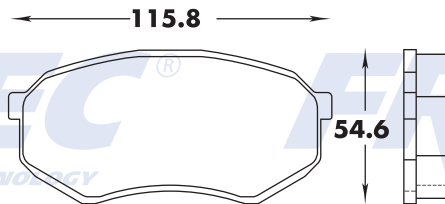

111

7328-Z1 D398

D/F	T/R	E/T
X		13.0

7328-Z1 D398

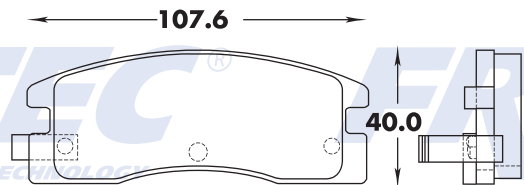

112

7329-Z1 D700

D/F	T/R	E/T
X		16.9

7329-Z1 D700

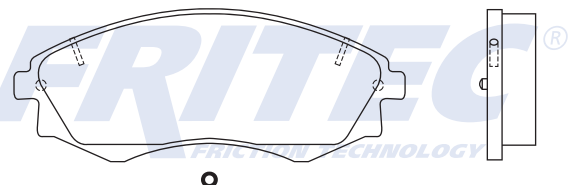
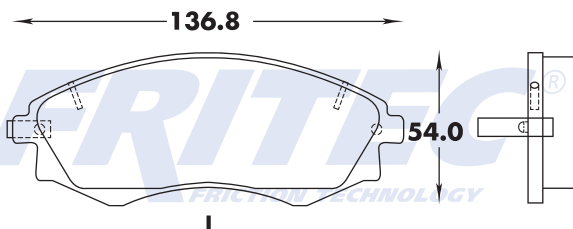

113

7330-Z D450

D/F	T/R	E/T
X		16.4

7330-Z D450

Technical drawing of brake pad 7330-Z D450. The front view shows a curved shape with a total width of 192.0 and a height of 70.0. The side view shows a thickness of 16.4. The drawing is labeled 'I' for the front view and 'O' for the side view.

114

7331-Z D451

D/F	T/R	E/T
X		14.9

7331-Z D451

Technical drawing of brake pad 7331-Z D451. The front view shows a curved shape with a total width of 107.3 and a height of 44.2. The side view shows a thickness of 14.9. The drawing is labeled 'I' for the front view and 'O' for the side view.

115

7335-Z D340

D/F	T/R	E/T
X		16.8

7335-Z D340

Technical drawing of brake pad 7335-Z D340. The front view shows a curved shape with a total width of 87.0 and a height of 53.0. The side view shows a thickness of 16.8. The drawing is labeled 'I' for the front view and 'O' for the side view.

116

7338-Z D458

D/F	T/R	E/T
X		12.2

7338-Z D458

Technical drawing of brake pad 7338-Z D458. The front view shows a curved shape with a total width of 102.2 and a height of 39.6. The side view shows a thickness of 12.2. The drawing is labeled 'I' for the front view and 'O' for the side view.

117

7339-Z D459

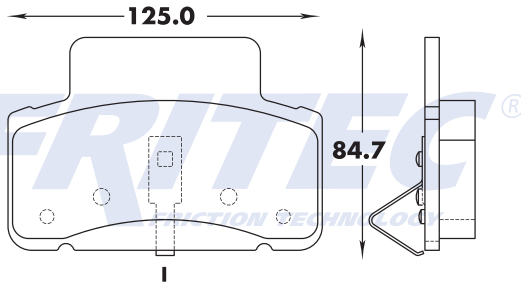

D/F	T/R	E/T
X		19.9, 16.9

7339-Z D459

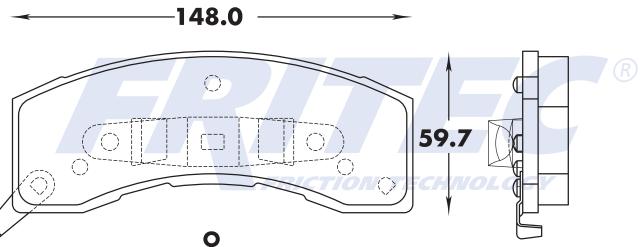

118

7339A-Z D459MA

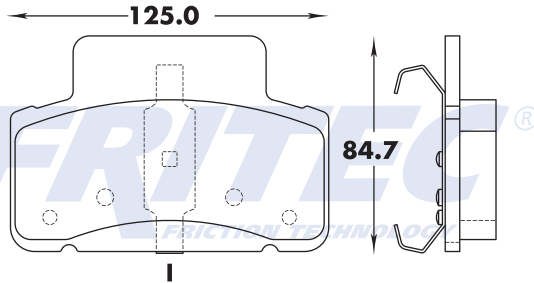

D/F	T/R	E/T
X		19.9, 16.9

7339A-Z D459MA

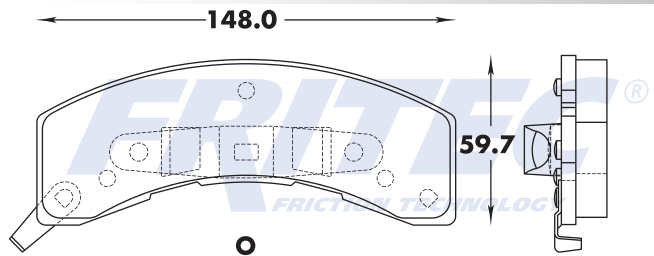

119

7342-Z D462

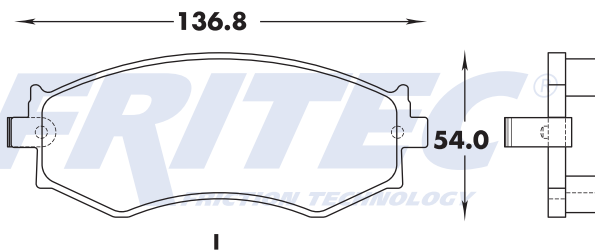

D/F	T/R	E/T
X		16.9

7342-Z D462

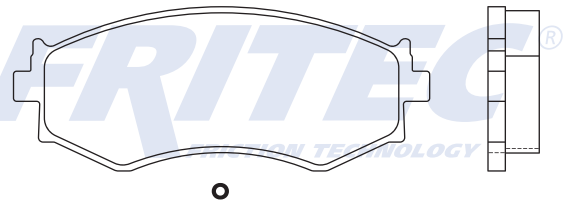

120

7345-Z D465

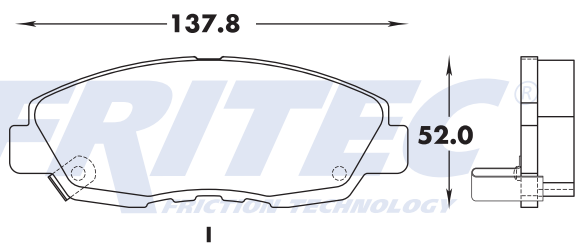

D/F	T/R	E/T
X		18.3

7345-Z D465

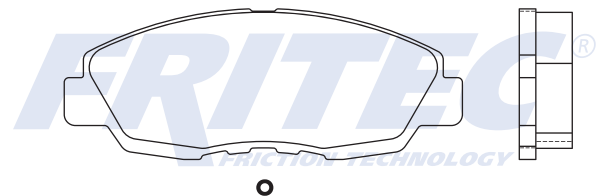

121

7347-Z D363

D/F	T/R	E/T
X		15.5

7347-Z D363

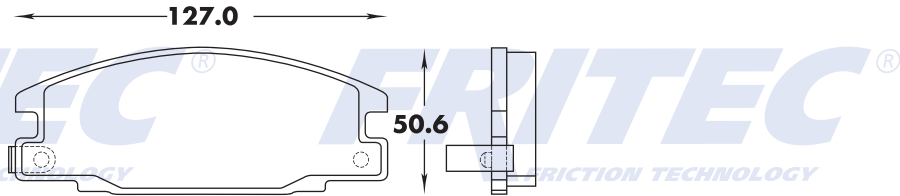

122

7353-Z D473

D/F	T/R	E/T
X		14.9

7353-Z D473



123

7357-Z D476

D/F	T/R	E/T
X		17.0

7357-Z D476

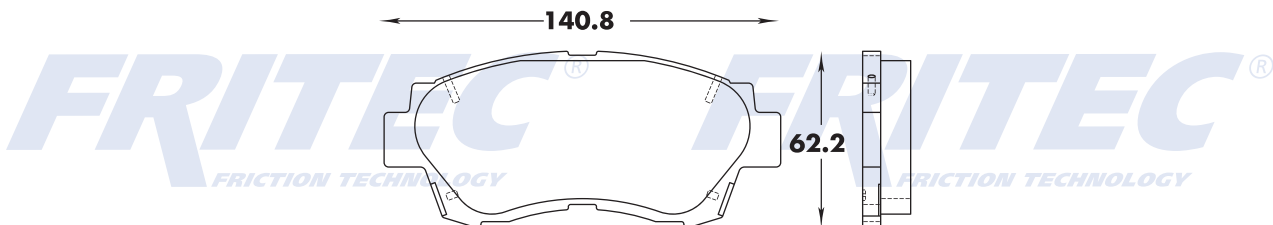

124

7357-Z1 D718

D/F	T/R	E/T
X		17.0

7357-Z1 D718

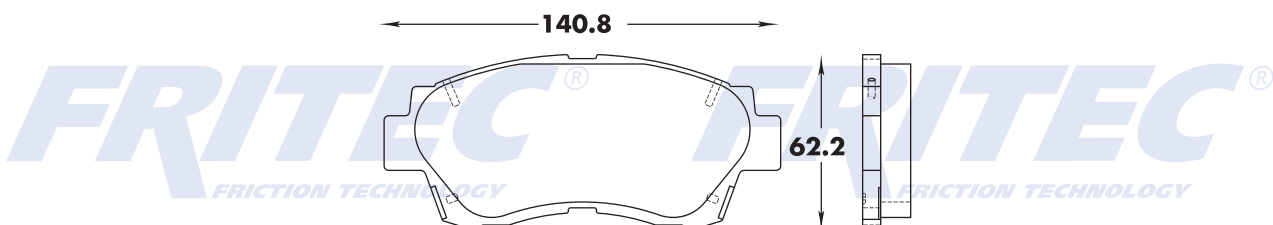

125

7361-Z D375

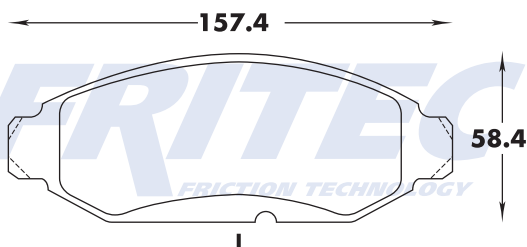

D/F	T/R	E/T
X		17.0, 13.2

7361-Z D375

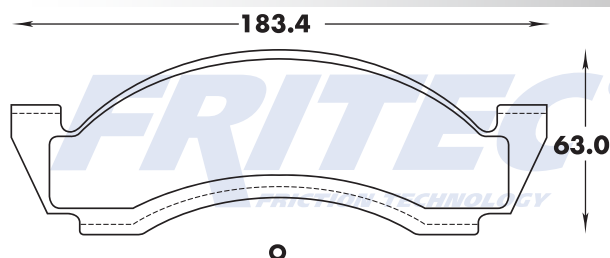

126

7365-Z D484

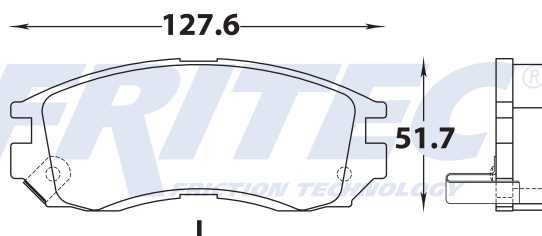

D/F	T/R	E/T
X		15.9

7365-Z D484

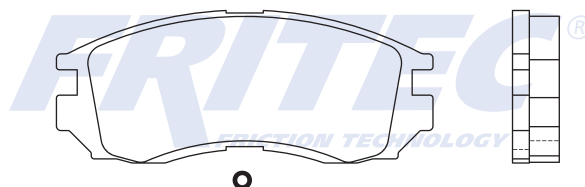

127

7376-Z D497

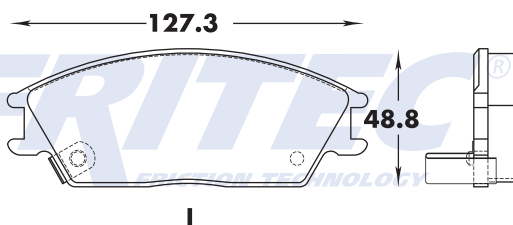

D/F	T/R	E/T
X		14.7

7376-Z D497

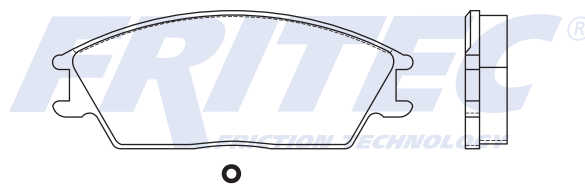

128

7378-Z D499

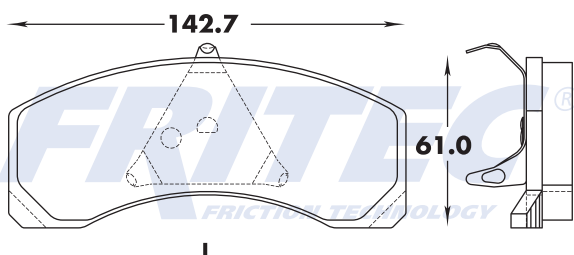

D/F	T/R	E/T
X		16.5, 14.6

7378-Z D499

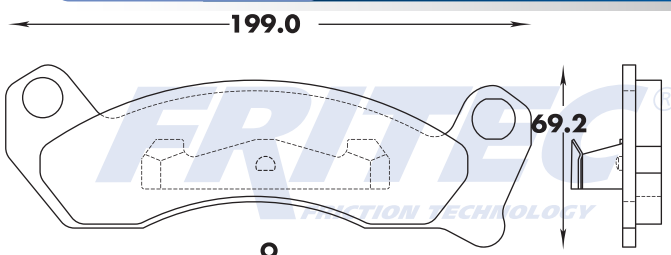

129

7382-Z D503

D/F	T/R	E/T
X		17.3

7382-Z D503

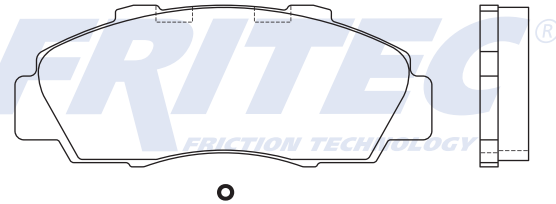
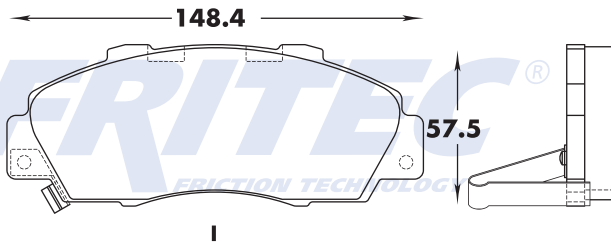

130

7384-Z D505

D/F	T/R	E/T
X		17.3, 16.0

7384-Z D505

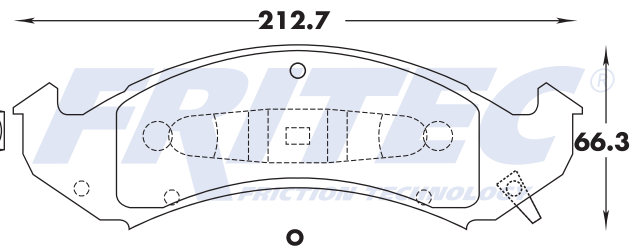
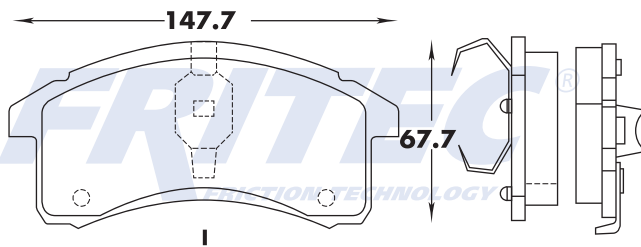

131

7384-Z1 D623

D/F	T/R	E/T
X		17.3, 16.0

7384-Z1 D623

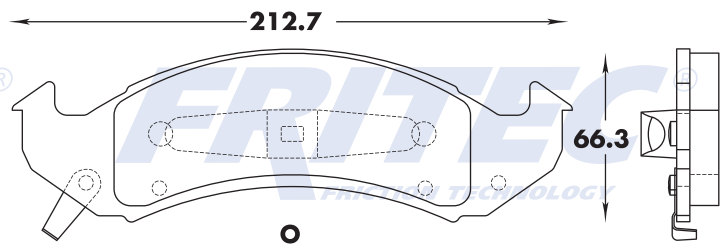
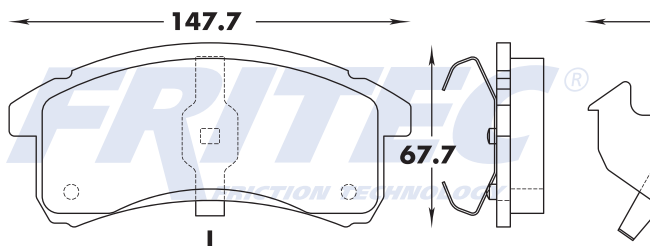

132

7385-Z D506

D/F	T/R	E/T
X		15.2, 12.8

7385-Z D506

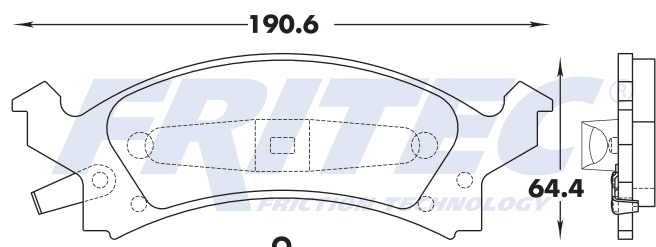
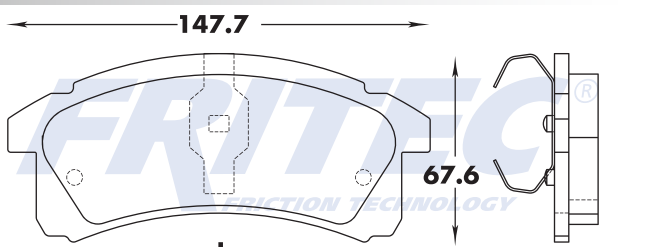

133

7386-Z D507

D/F	T/R	E/T
X		16.8

7386-Z D507

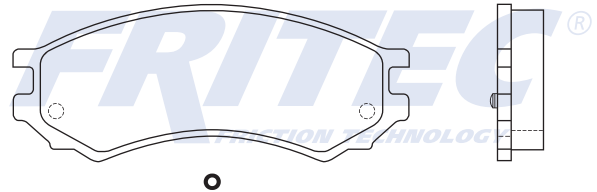
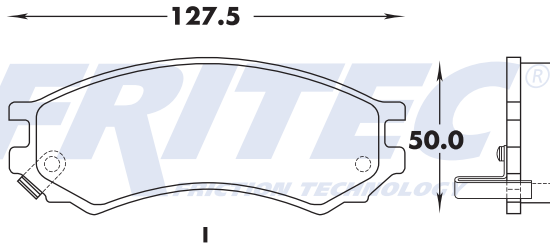

134

7387-Z D508

D/F	T/R	E/T
X		13.8

7387-Z D508

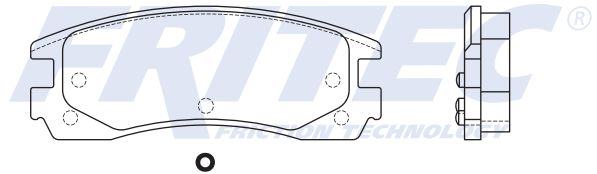
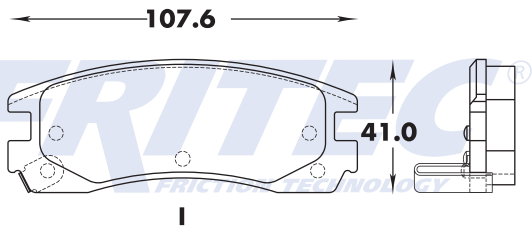

135

7387-Z2 D714

D/F	T/R	E/T
X		13.8

7387-Z2 D714

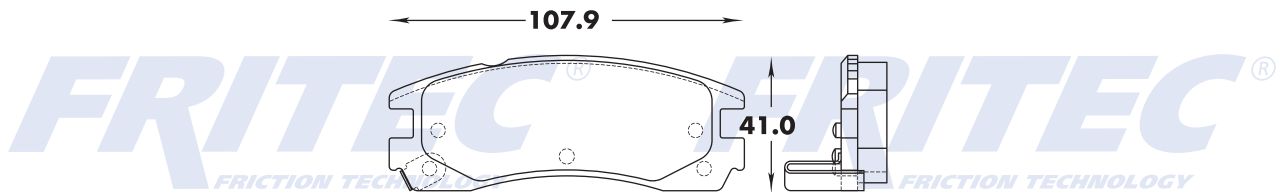

136

7387-Z3 D814

D/F	T/R	E/T
X		13.8

7387-Z3 D814

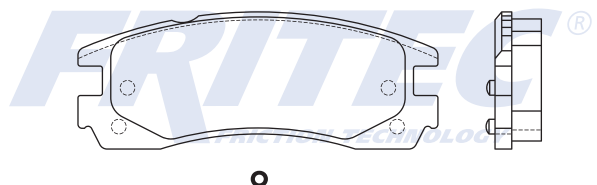
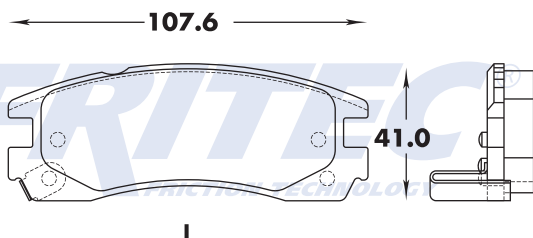

137

7388-Z D509

D/F	T/R	E/T
X		15.9

7388-Z D509

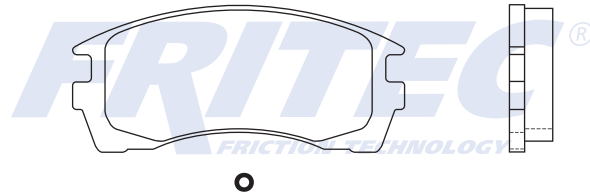
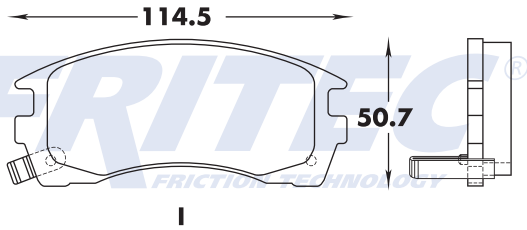

138

7389-Z D510

D/F	T/R	E/T
X		16.5

7389-Z D510

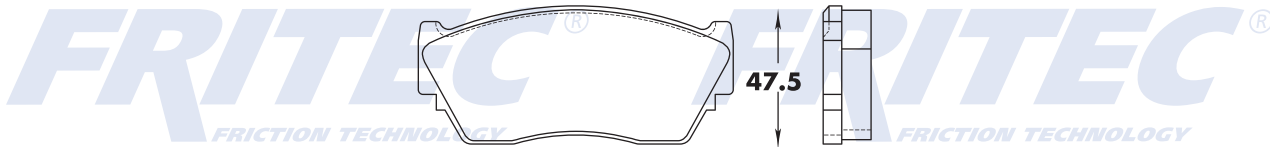
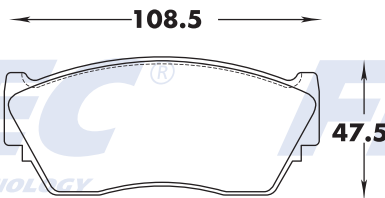

139

7390-Z D511

D/F	T/R	E/T
X		16.0

7390-Z D511

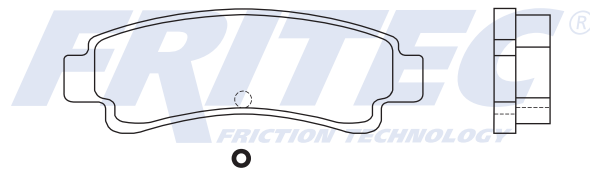
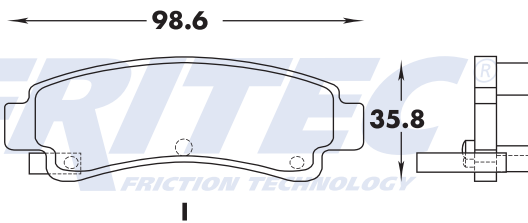

140

9151-Z D1926

D/F	T/R	E/T
X		16.8

9151-Z D1926

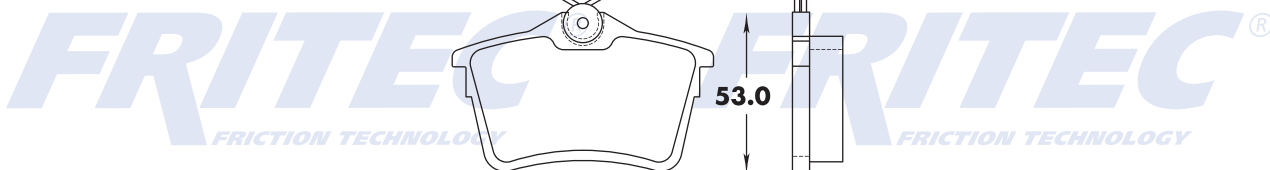
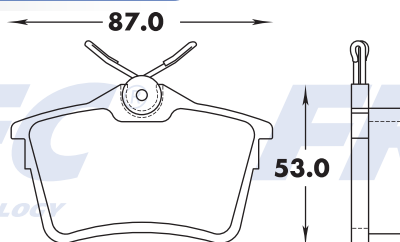

141

7404-AZ D522

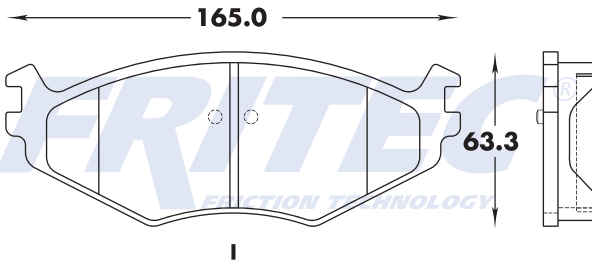

D/F	T/R	E/T
X		18.3, 16.3

7404-AZ D522

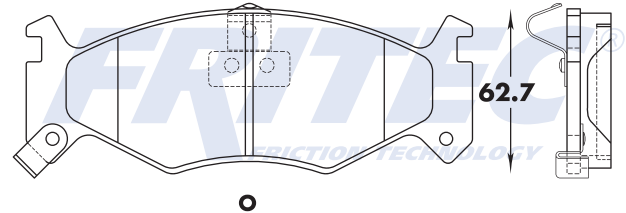

142

7406-Z D524

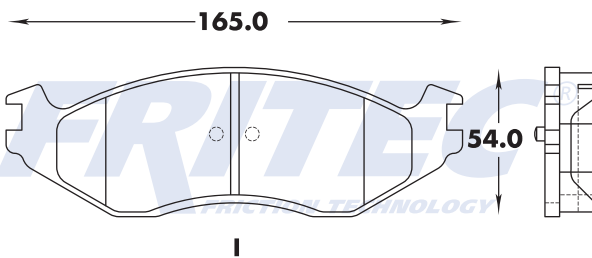

D/F	T/R	E/T
X		18.2, 16.1

7406-Z D524

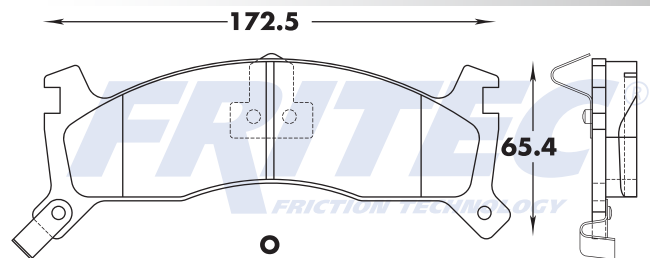

143

7410-Z D529

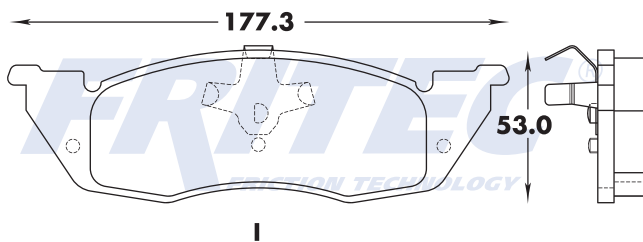

D/F	T/R	E/T
X		17.5

7410-Z D529

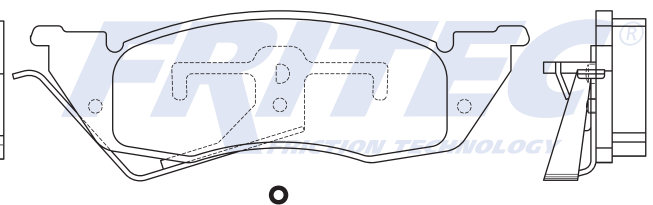

144

7410-AZ D593

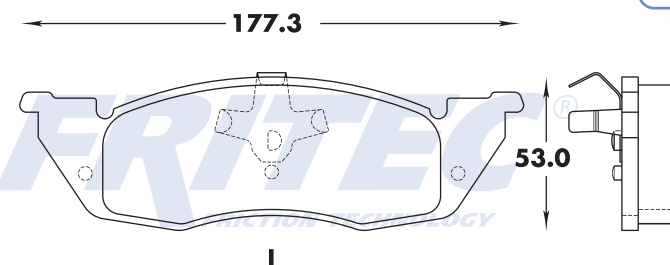

D/F	T/R	E/T
X		17.5

7410-AZ D593

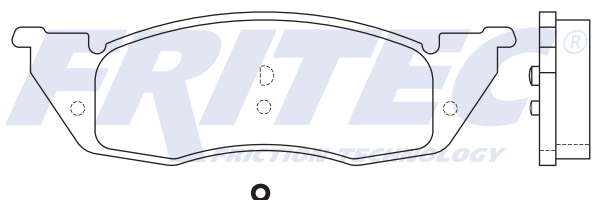

145

7412-Z D530

D/F	T/R	E/T
X		15.7

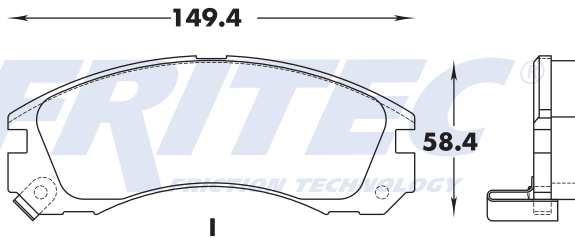

7412-Z D530

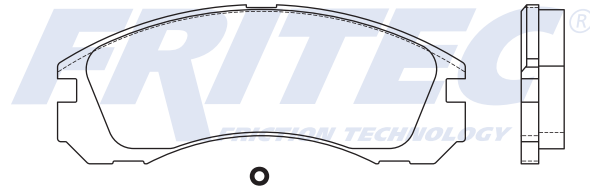

146

7414-Z D532

D/F	T/R	E/T
X		15.2

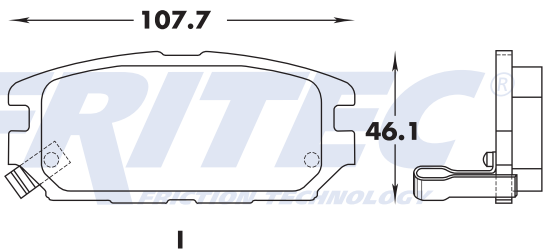

7414-Z D532

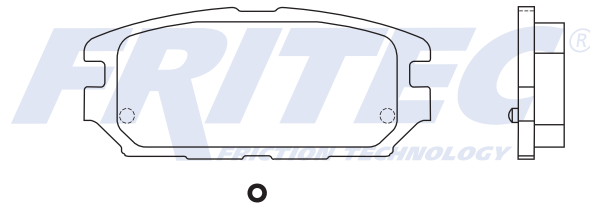

147

7418-Z D536

D/F	T/R	E/T
X		14.6

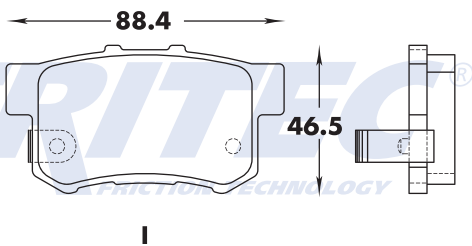

7418-Z D536

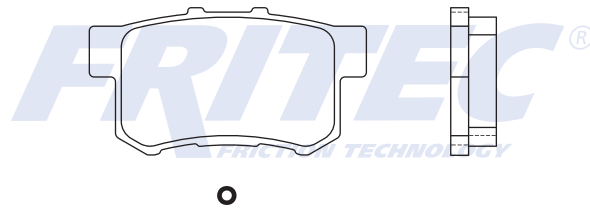

148

7418-Z1 D537

D/F	T/R	E/T
X		14.6

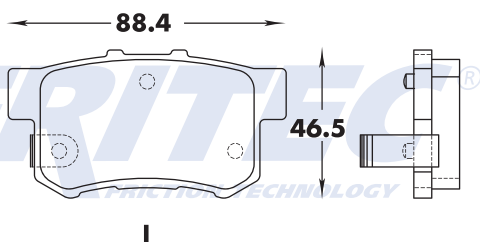

7418-Z1 D537

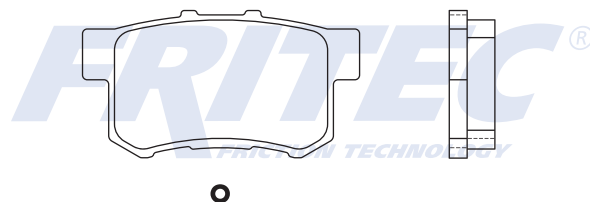

149

7418-Z3 D1086

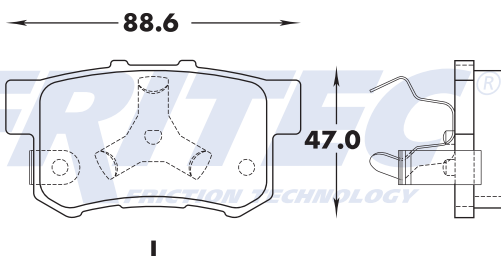

D/F	T/R	E/T
X		14.6

7418-Z3 D1086

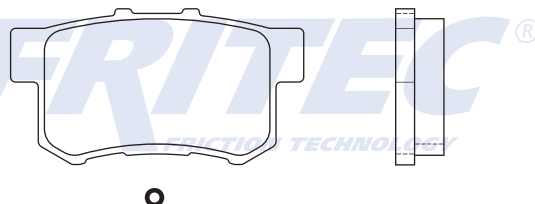

150

7421-Z1 D595

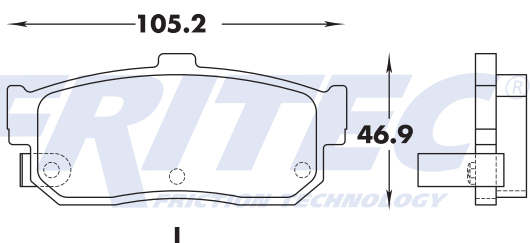

D/F	T/R	E/T
X		16.3

7421-Z1 D595

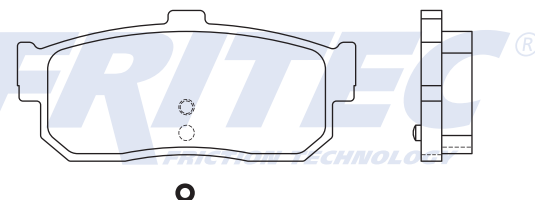

151

7424-Z D544

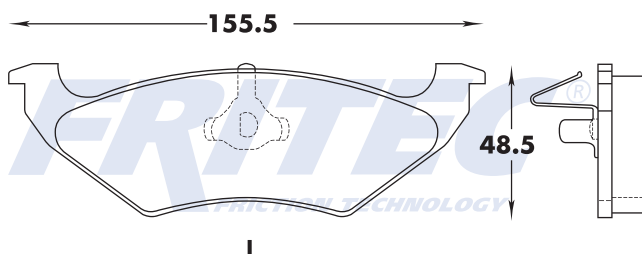

D/F	T/R	E/T
X		16.0

7424-Z D544

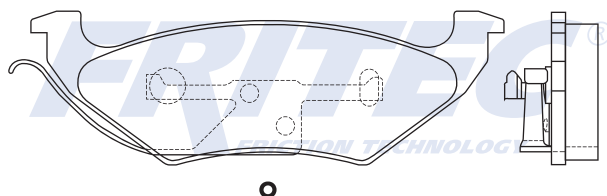

152

7427-Z D1042

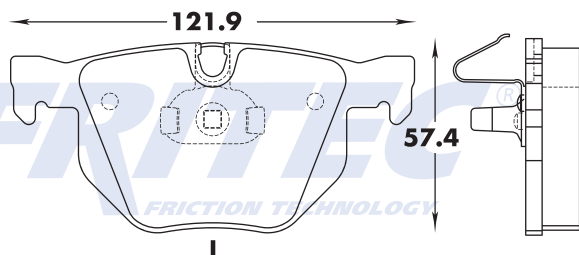

D/F	T/R	E/T
X		16.3

7427-Z D1042

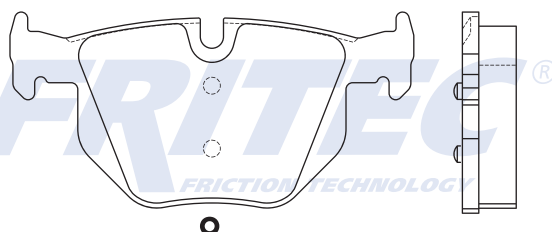

153

7427-Z1 D1170

D/F	T/R	E/T
X		16.3

7427-Z1 D1170

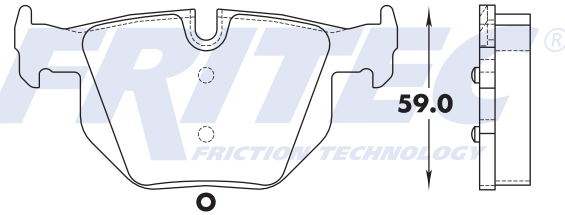
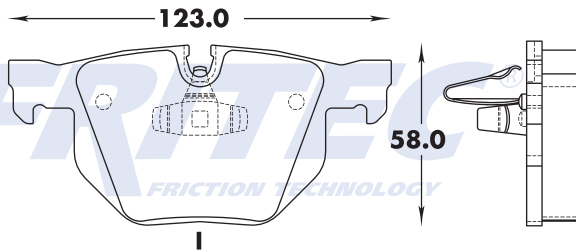

154

7427-Z2 D683

D/F	T/R	E/T
X		16.3

7427-Z2 D683

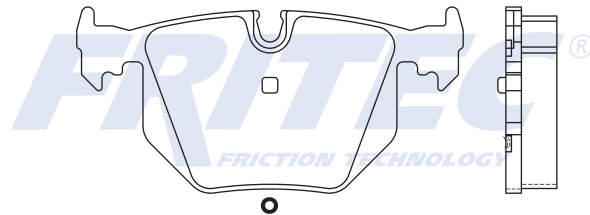
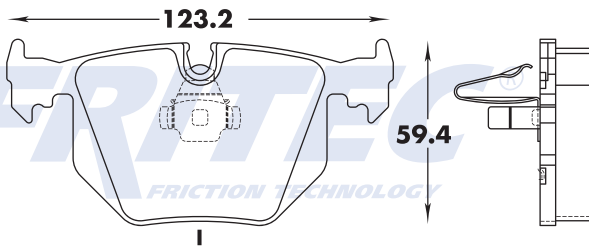

155

7428-Z D549

D/F	T/R	E/T
X		14.9

7428-Z D549

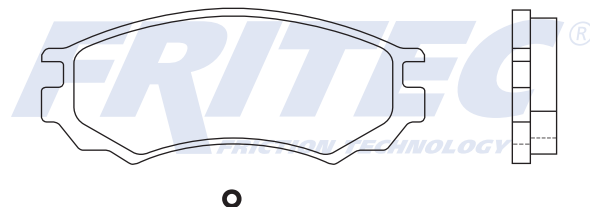
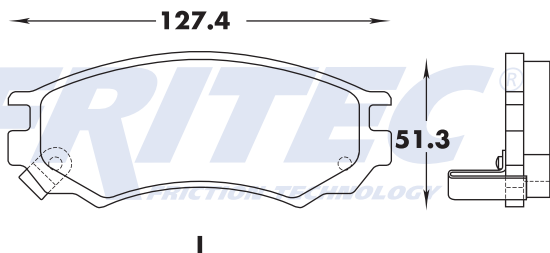

156

7430-Z D551

D/F	T/R	E/T
X		15.9

7430-Z D551

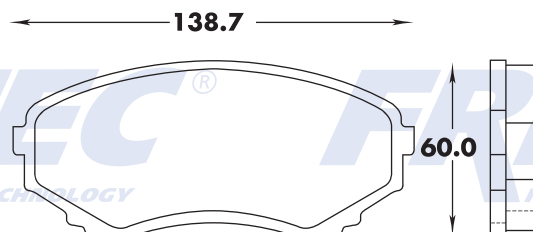

157

7434-Z D555

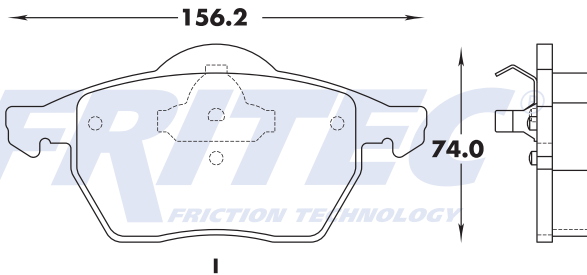

D/F	T/R	E/T
X		19.3

7434-Z D555

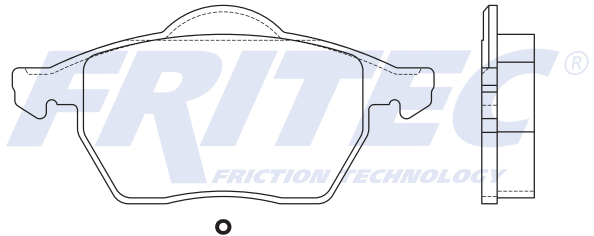

158

7434-AZ D555

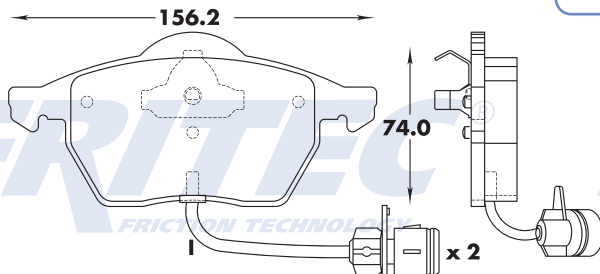

D/F	T/R	E/T
X		19.3

7434-AZ D555

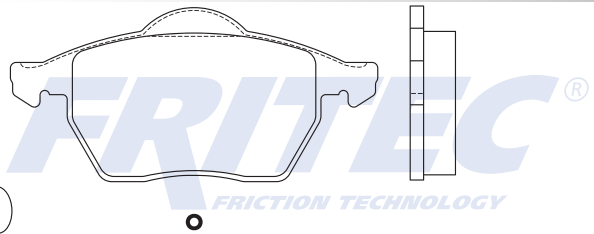

159

7435-Z D556

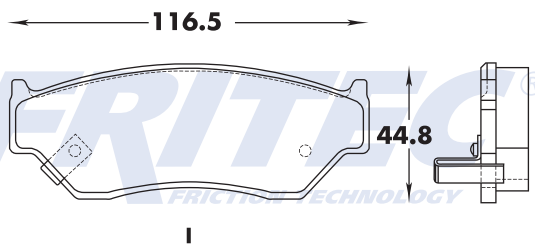

D/F	T/R	E/T
X		15.4

7435-Z D556

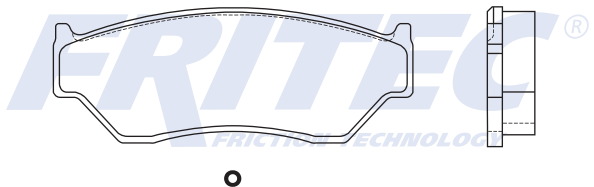

160

7436-Z D557

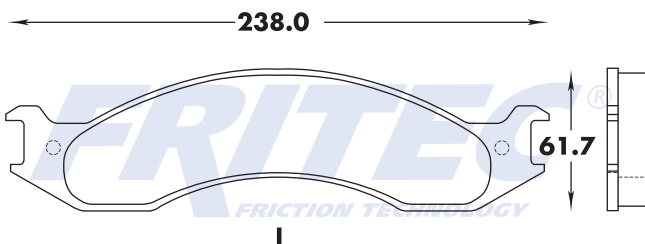

D/F	T/R	E/T
X		19.7

7436-Z D557

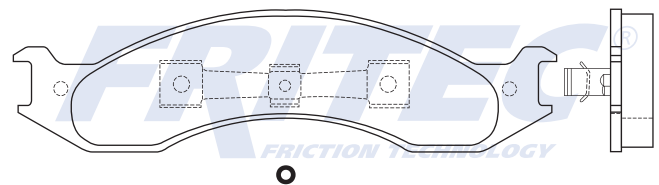

161

7437-Z D558

D/F	T/R	E/T
X		17.0

7437-Z D558

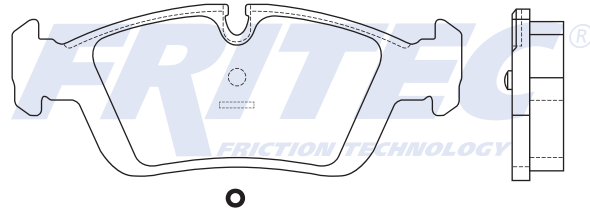
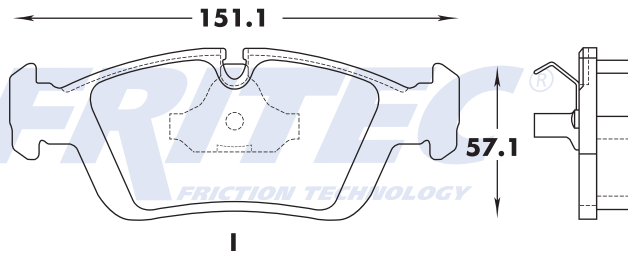

162

7438-AZ D658

D/F	T/R	E/T
X		15.7

7438-AZ D658

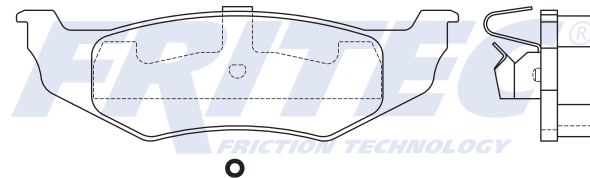
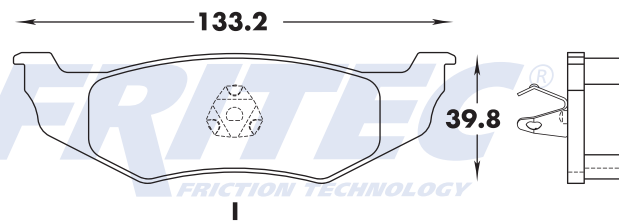

163

7438-BZ D641

D/F	T/R	E/T
X		17.0

7438-BZ D641

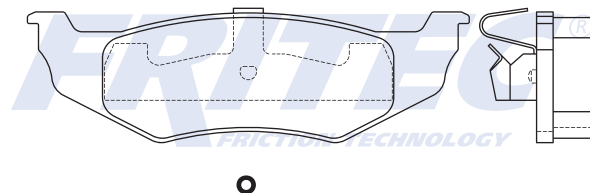
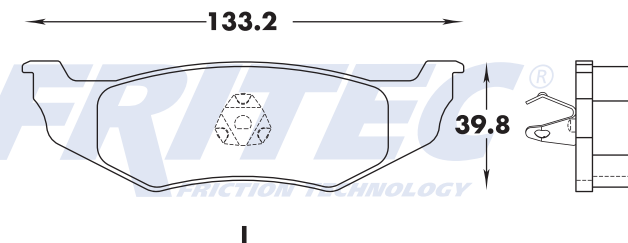

164

8284-D1173

D/F	T/R	E/T
X		14.7

8284-D1173

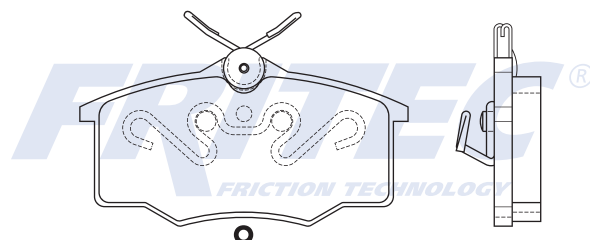
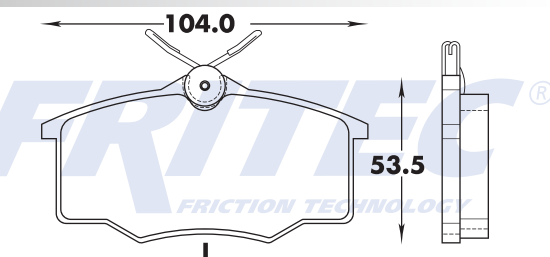

165

7441-Z D562

D/F	T/R	E/T
X		17.5

7441-Z D562

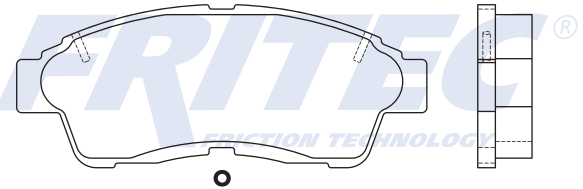
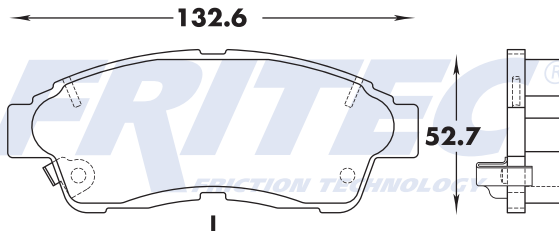

166

7443-Z D564

D/F	T/R	E/T
X		12.6

7443-Z D564

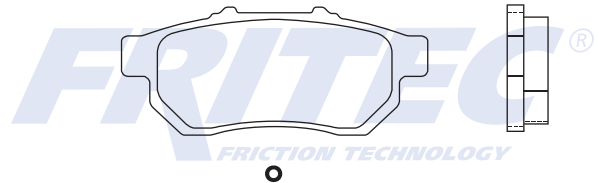
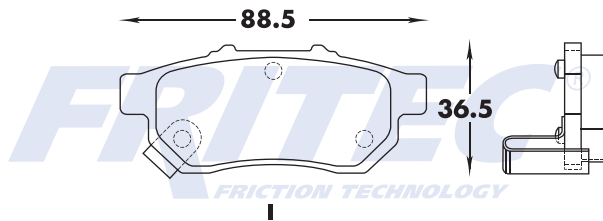

167

7456-Z D576

D/F	T/R	E/T
X		15.7

7456-Z D576

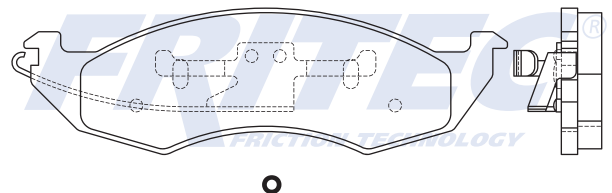
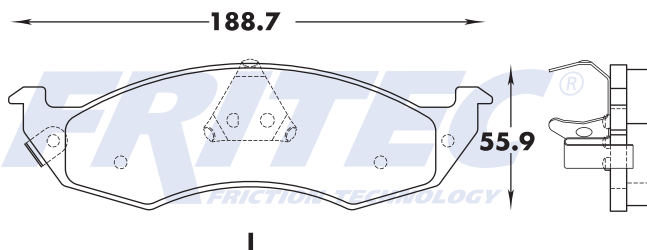

168

7459-Z D579

D/F	T/R	E/T
X		16.5

7459-Z D579

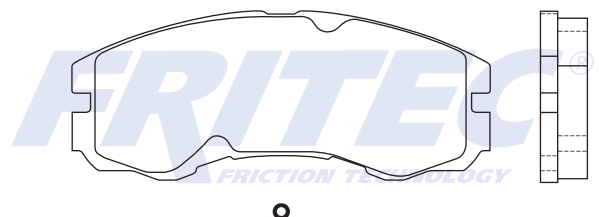
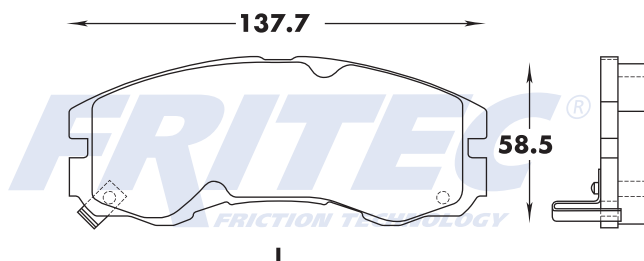

169

7460-Z D580

D/F	T/R	E/T
X		15.7

7460-Z D580

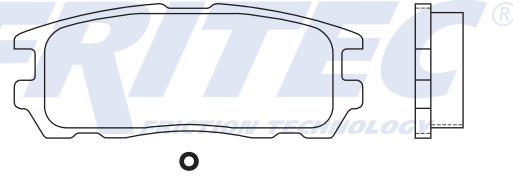
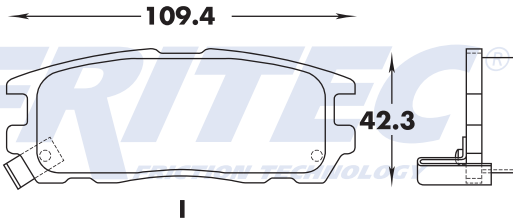

170

7463-Z D583

D/F	T/R	E/T
X		16.1, 15.0

7463-Z D583

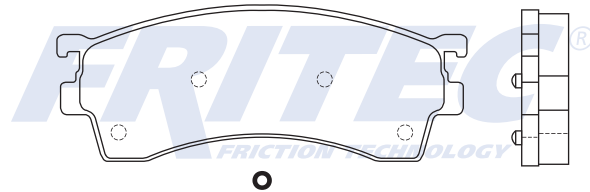
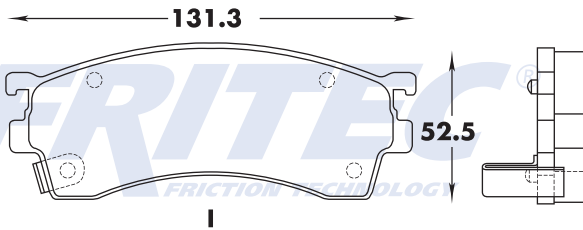

171

7464-Z D584

D/F	T/R	E/T
X		13.6

7464-Z D584

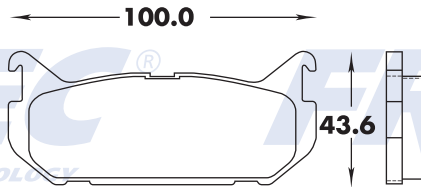

172

7470-AZ D591

D/F	T/R	E/T
X		18.3, 15.9

7470-AZ D591

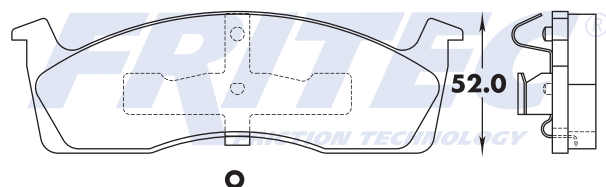
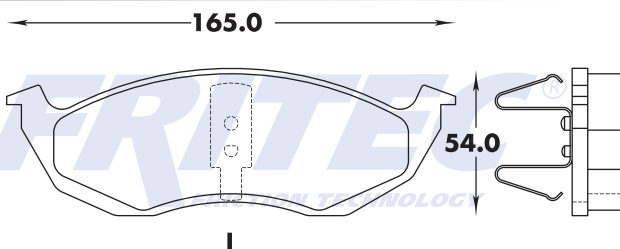

173

7476-Z D598

D/F	T/R	E/T
X		17.5

7476-Z D598

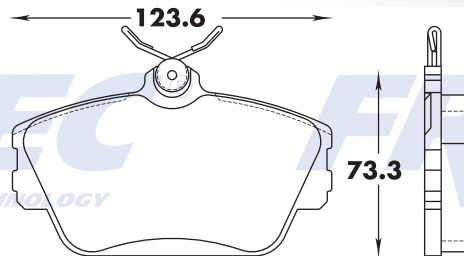

174

7477-Z D599

D/F	T/R	E/T
X		16.9

7477-Z D599

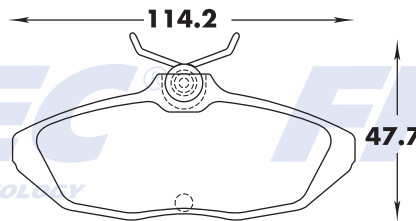

175

7478-Z D600

D/F	T/R	E/T
X		17.1

7478-Z D600

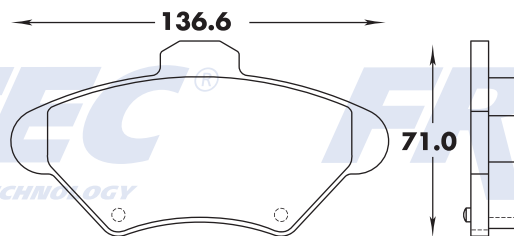

176

7479-Z D601

D/F	T/R	E/T
X		17.5

7479-Z D601

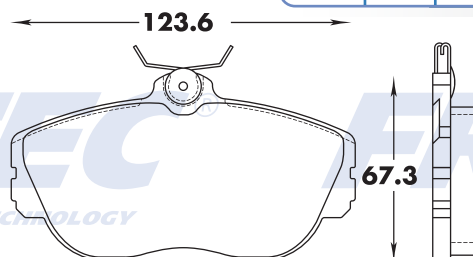

177

7480-Z D202

D/F	T/R	E/T
X		15.2, 12.6

7480-Z D202

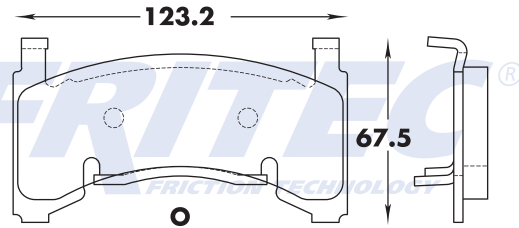
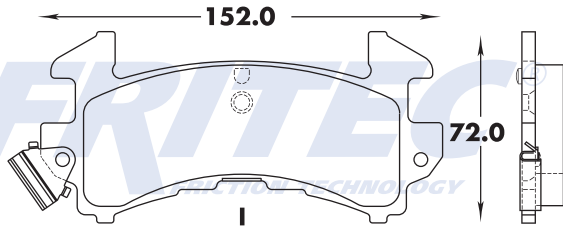

178

7485-Z D604

D/F	T/R	E/T
X		16.4

7485-Z D604

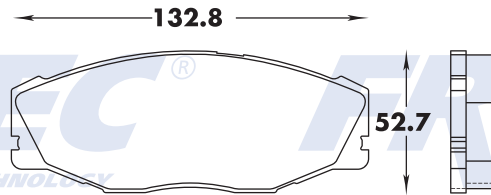

179

7487-Z D606

D/F	T/R	E/T
X		15.5

7487-Z D606

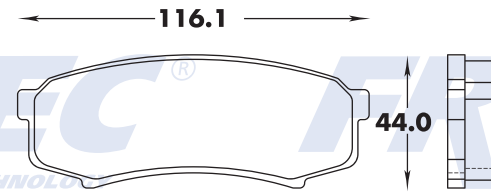

180

7488-Z D607

D/F	T/R	E/T
X		14.9, 14.1

7488-Z D607

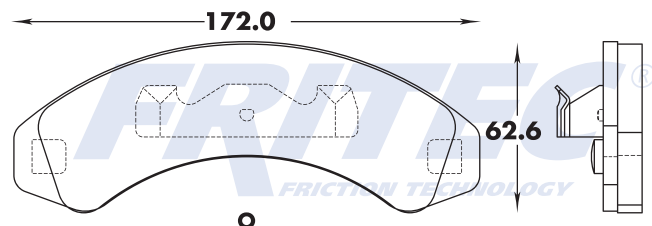
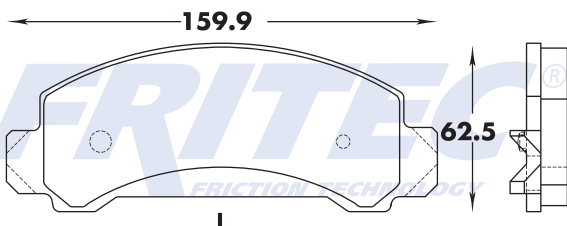

181

7489-Z D610

D/F	T/R	E/T
X		16.8

7489-Z D610

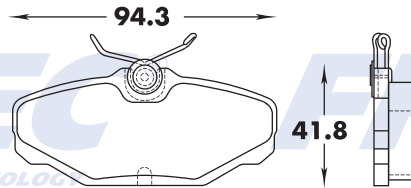

182

7493-Z D617

D/F	T/R	E/T
X		16.4, 16.4

7493-Z D617

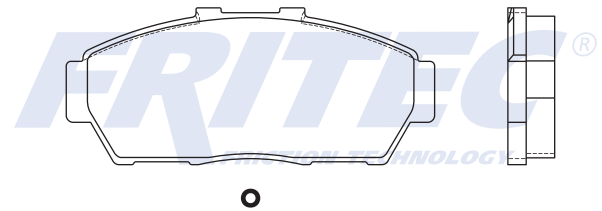
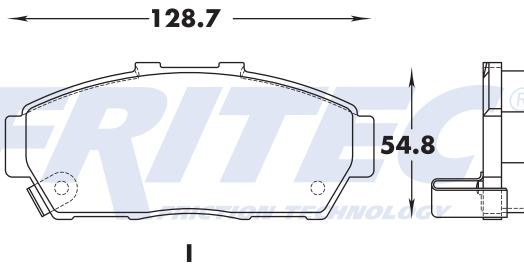

183

7497-Z1 D948

D/F	T/R	E/T
X		16.4

7497-Z1 D948

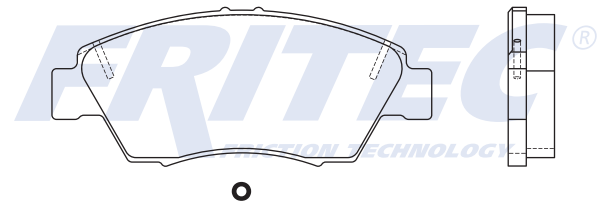
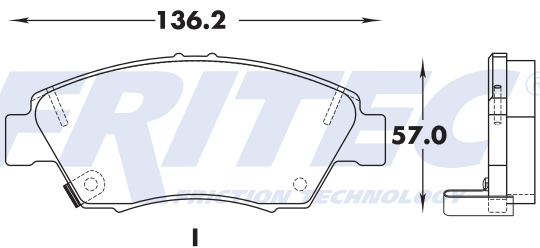

184

74X6-Z F041

D/F	T/R	E/T
X		16.5

74X6-Z F041

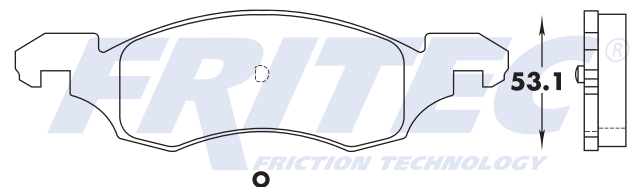
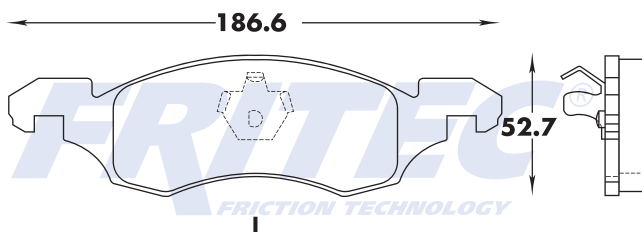

185

8433-D1321

D/F	T/R	E/T
X		16.0

8433-D1321

127.0

48.0

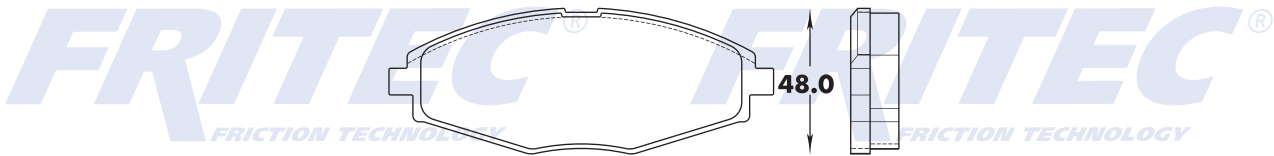

186

7502-Z D625

D/F	T/R	E/T
X		15.1

7502-Z D625

141.0

45.6

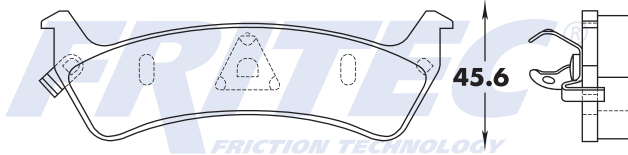

I

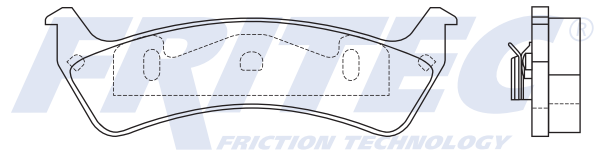

O

187

7502-AZ D666

D/F	T/R	E/T
X		15.1

7502-AZ D666

143.2

44.6

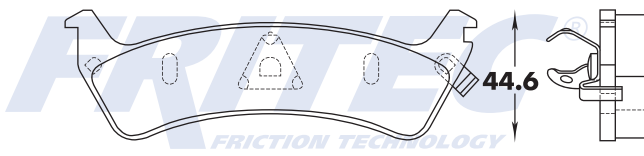

I

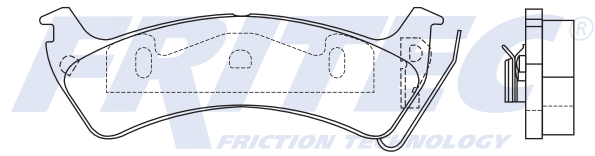

O

143.2

44.6

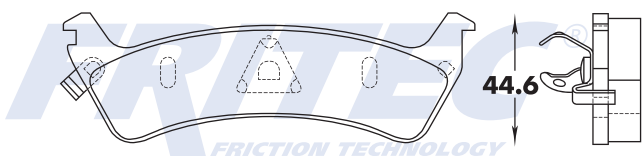

I

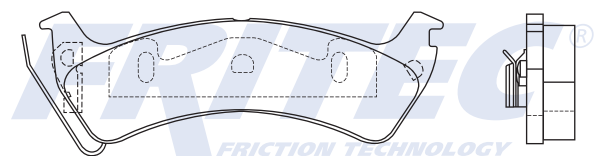

O

188

7503-Z D632

D/F	T/R	E/T
X		16.0

7503-Z D632

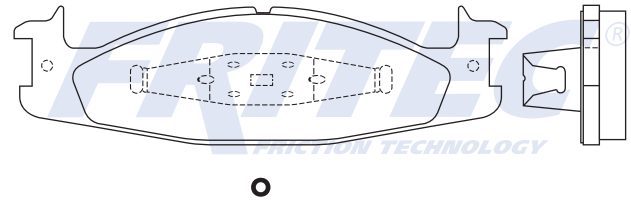
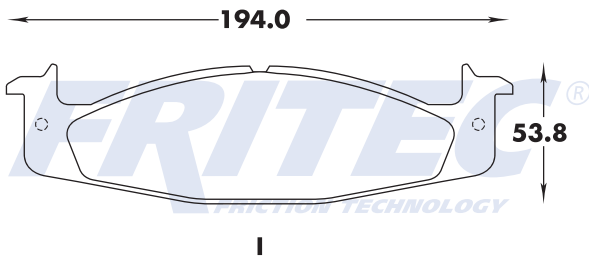

189

7504-Z D627

D/F	T/R	E/T
X		17.1

7504-Z D627

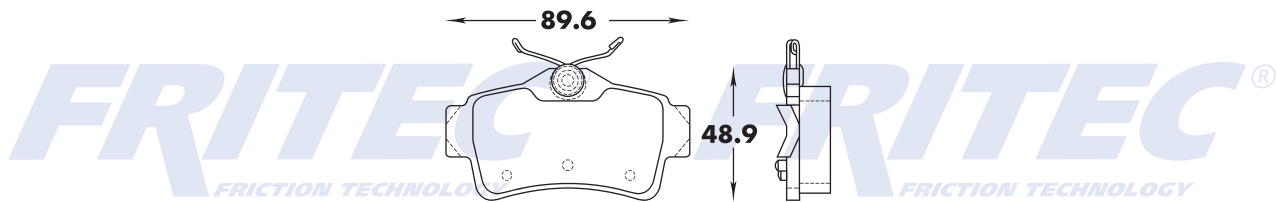

190

7507-AZ D477

D/F	T/R	E/T
X		16.5

7507-AZ D477

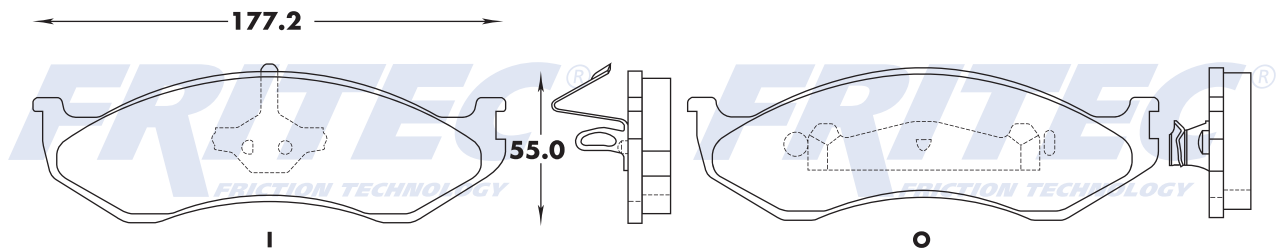

191

7511-AZ D633

D/F	T/R	E/T
X		16.1

7511-AZ D633

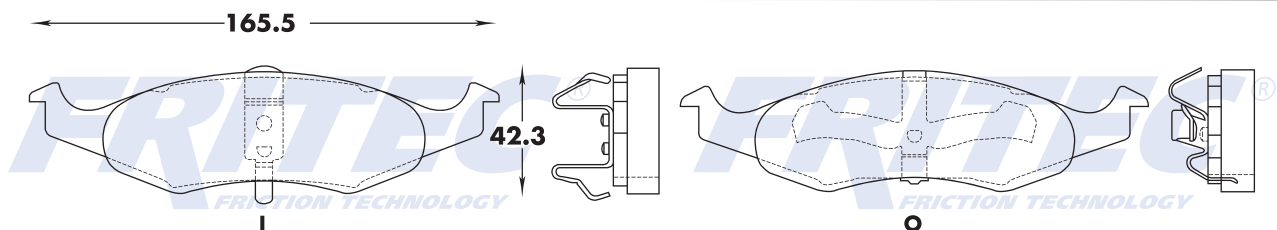

192

7514-Z D636

D/F	T/R	E/T
X		12.4

7514-Z D636

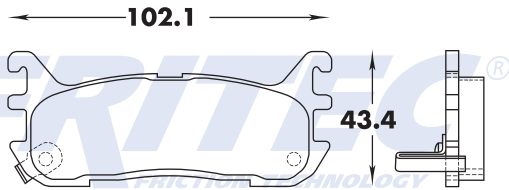

I

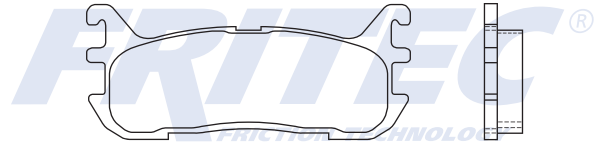

O

193

7514-Z1 D663

D/F	T/R	E/T
X		12.4

7514-Z1 D663

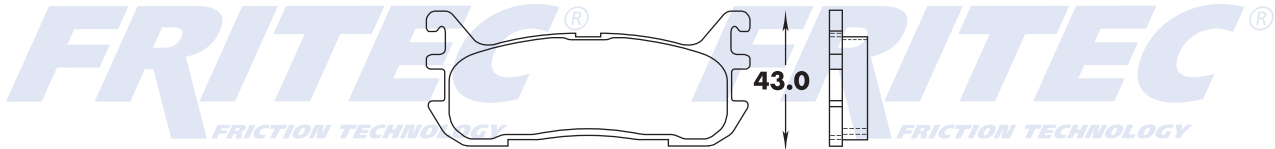
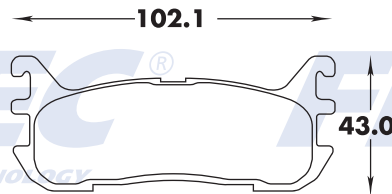

194

7515-Z D637

D/F	T/R	E/T
X		15.4, 14.5

7515-Z D637

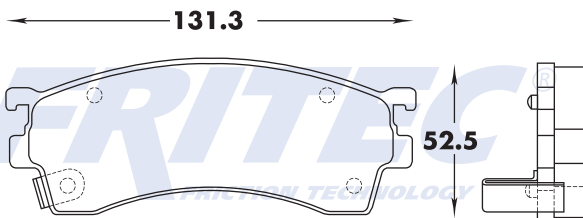

I

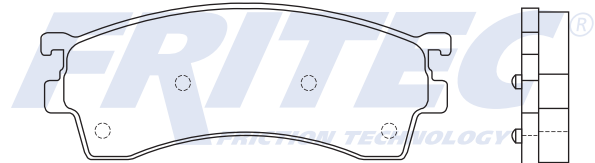

O

195

7518-AZ D642

D/F	T/R	E/T
X		16.3, 15.9

7518-AZ D642

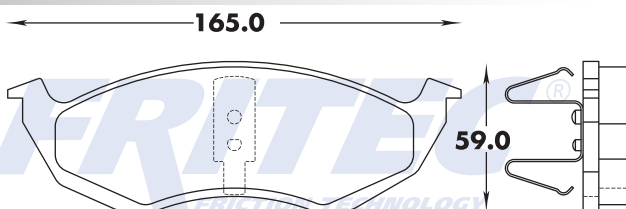

I

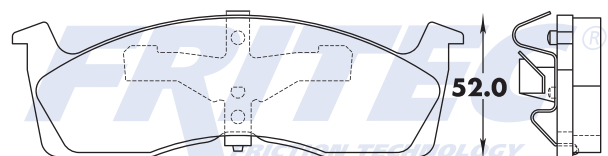

O

196

7524-Z D627

D/F	T/R	E/T
X		15.0

7524-Z D627

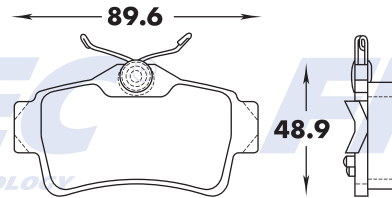

197

7528-Z D648

D/F	T/R	E/T
X		18.4, 17.8

7528-Z D648

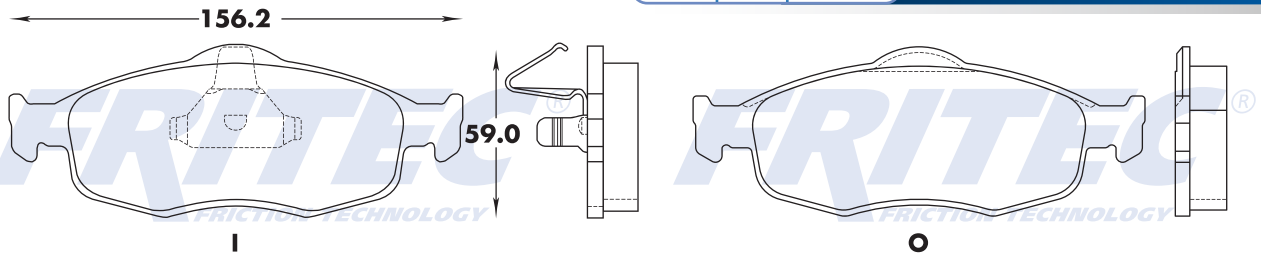

198

7529-Z D649

D/F	T/R	E/T
X		17.3

7529-Z D649

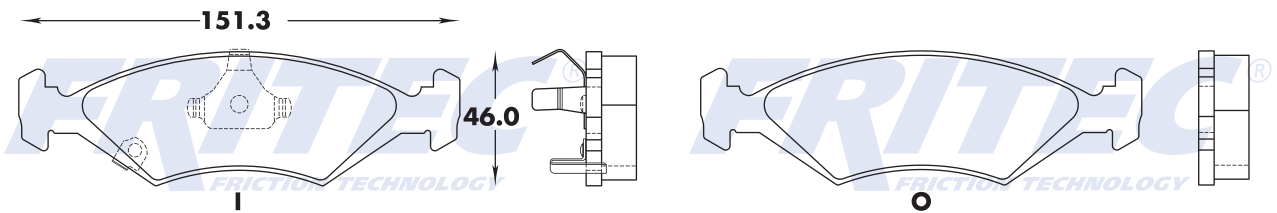

199

7530-AZ D650

D/F	T/R	E/T
X		16.0, 15.1

7530-AZ D650

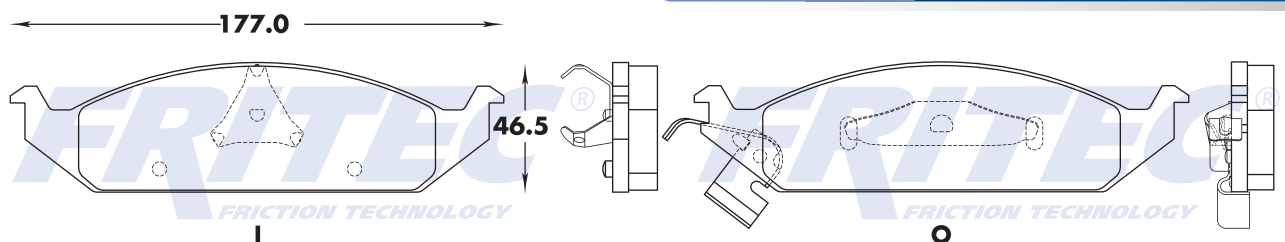

200

7531-Z D651

D/F	T/R	E/T
X		16.1

7531-Z D651

177.0

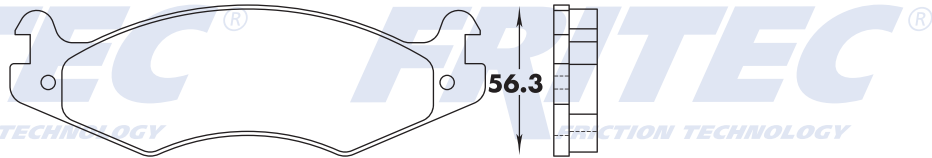

201

7532-Z D652

D/F	T/R	E/T
X		16.5

7532-Z D652

153.8

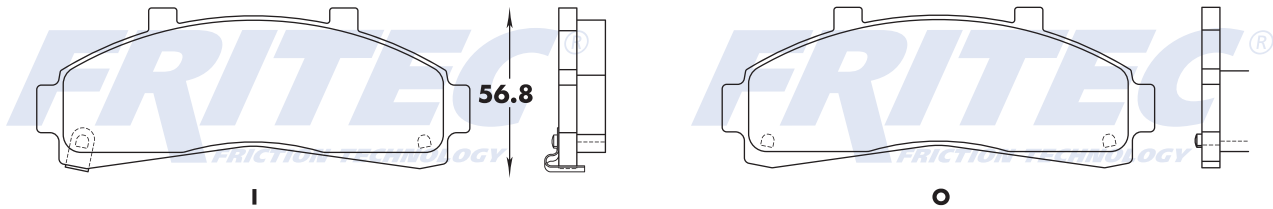

202

7533-Z D540

D/F	T/R	E/T
X		16.3

7533-Z D540

105.2

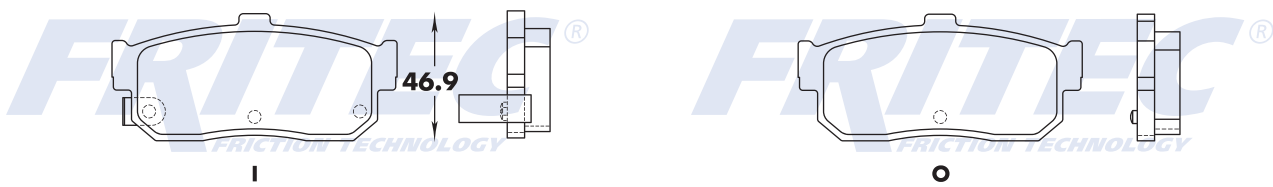

203

7535-Z D655

D/F	T/R	E/T
X		18.7

7535-Z D655

220.0

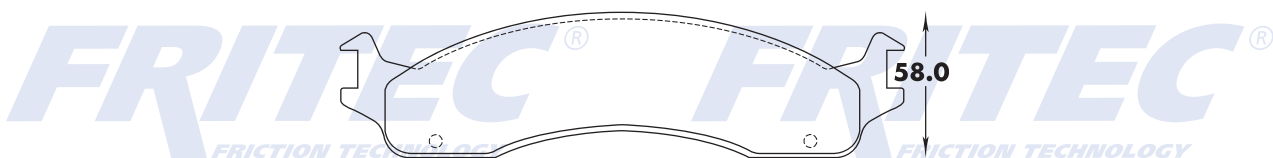

204

7536-Z D656

D/F	T/R	E/T
X		17.0

7536-Z D656

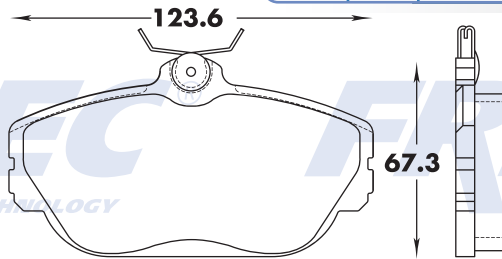

205

7537-Z1 D678

D/F	T/R	E/T
X		17.1

7537-Z1 D678

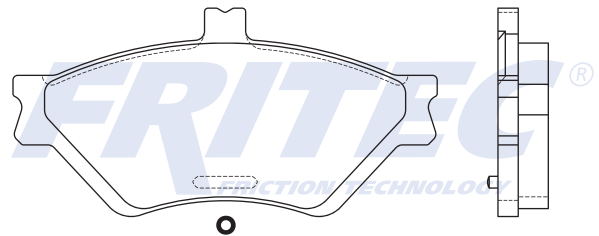
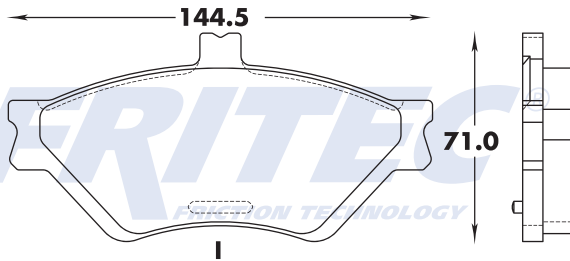

206

7538-Z D561

D/F	T/R	E/T
X		14.0

7538-Z D561

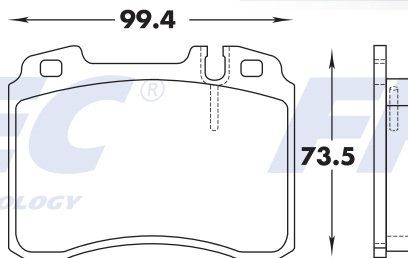

207

7541-Z D661

D/F	T/R	E/T
X		14.7

7541-Z D661

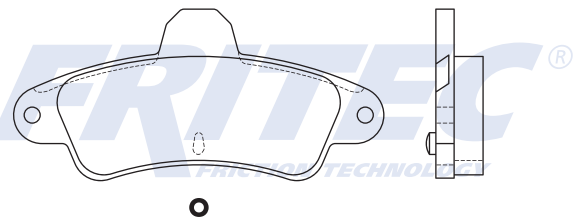
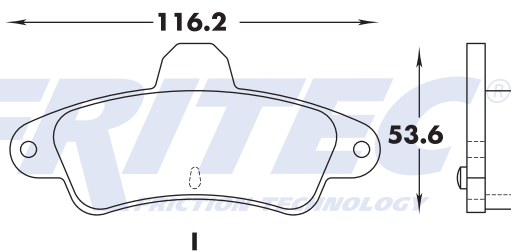

208

7543-Z D664

D/F	T/R	E/T
X		14.6

7543-Z D664

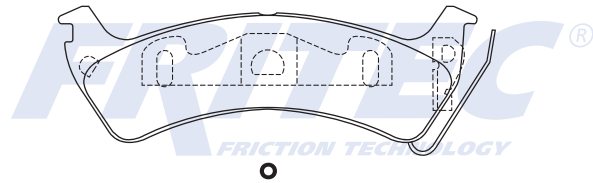
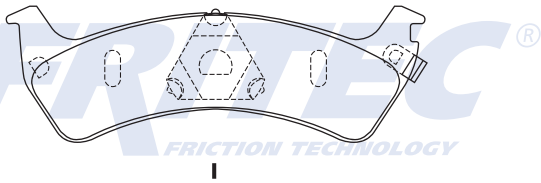
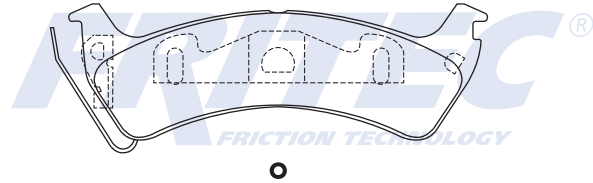
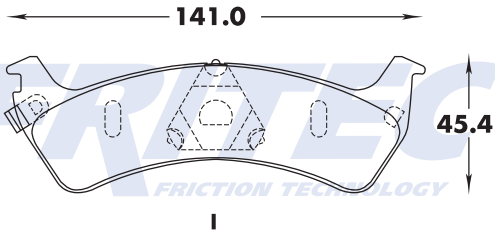

209

7545-AZ D667

D/F	T/R	E/T
X		14.5

7545-AZ D667

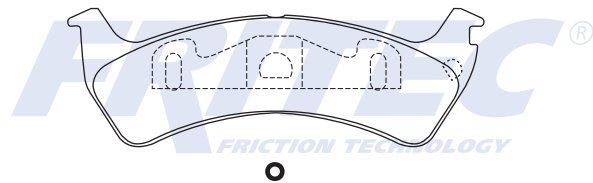
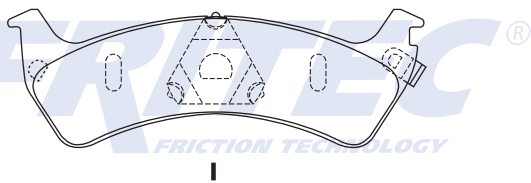
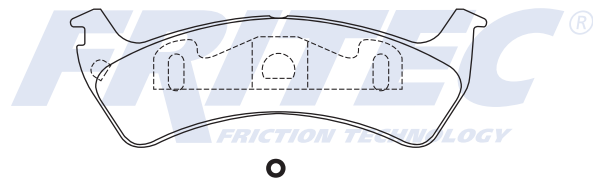
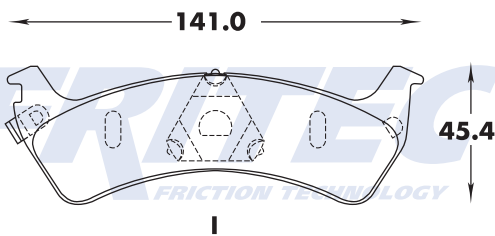

210

7546-Z D668

D/F	T/R	E/T
X		15.7

7546-Z D668

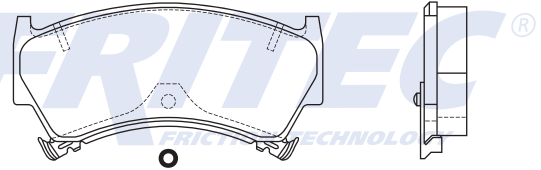
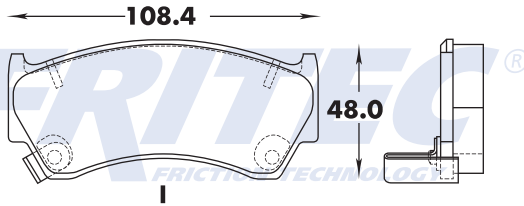

211

7547-Z D669

D/F	T/R	E/T
X		14.9

7547-Z D669

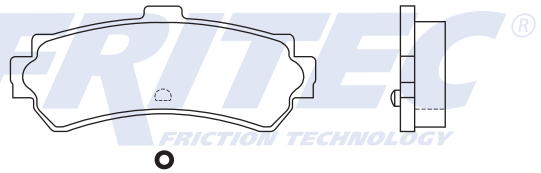
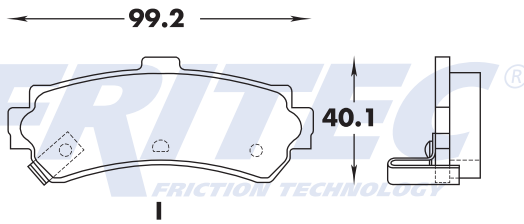

212

7548-Z D433

D/F	T/R	E/T
X		17.4

7548-Z D433

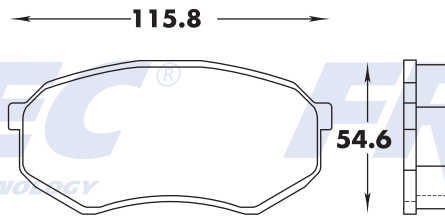

D/F	T/R	E/T

213

7549-Z D436

D/F	T/R	E/T
X		17.0

7549-Z D436

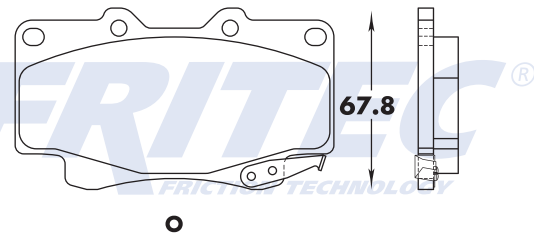
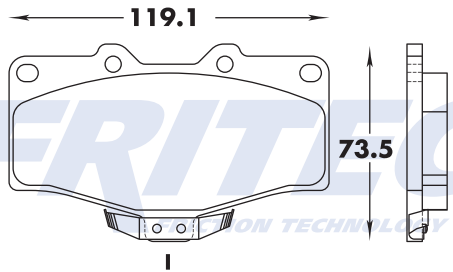
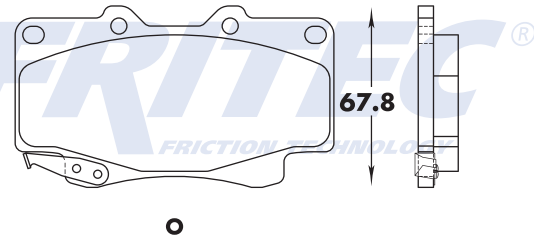
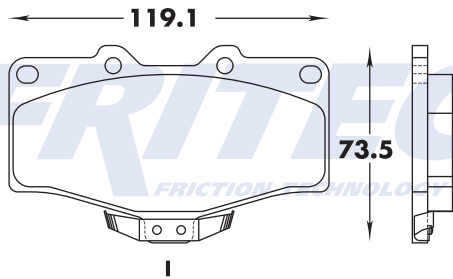

214

754X-Z F059

D/F	T/R	E/T
X		15.0

754X-Z F059

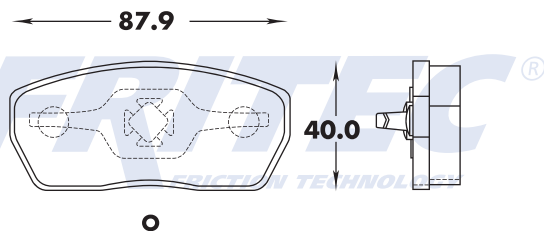
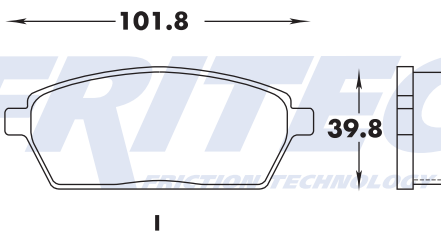

215

7554-Z D673

D/F	T/R	E/T
X		14.6, 13.6

7554-Z D673

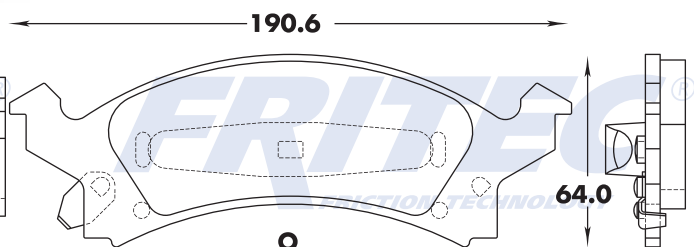
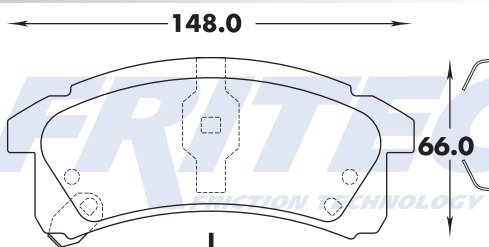

216

7555-Z D674

D/F	T/R	E/T
X		16.0

7555-Z D674

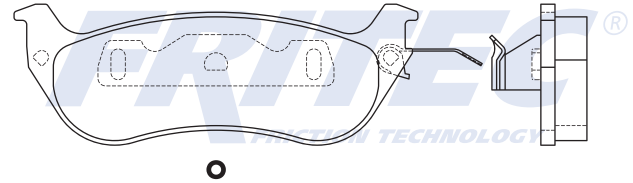
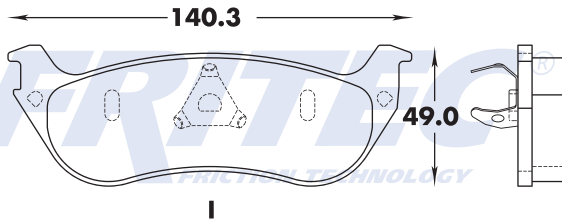

217

7558-Z D679

D/F	T/R	E/T
X		16.3

7558-Z D679

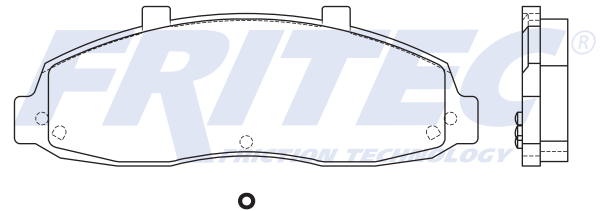
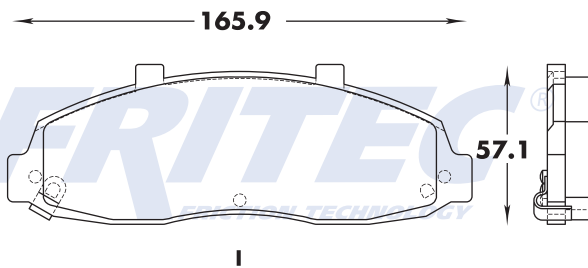

218

7559-Z D680

D/F	T/R	E/T
X		14.3

7559-Z D680

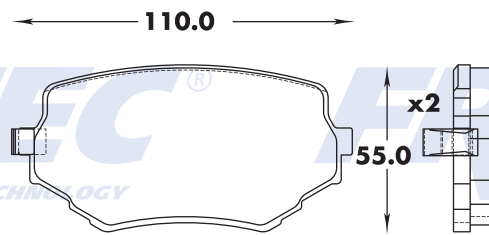

219

7560-Z D681

D/F	T/R	E/T
X		18.3

7560-Z D681

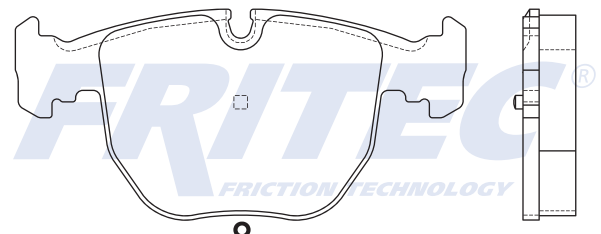
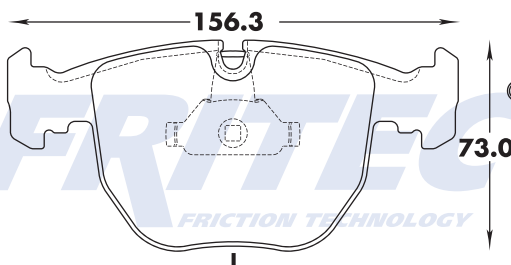

220

7563-Z D688

D/F	T/R	E/T
X		16.3

7563-Z D688

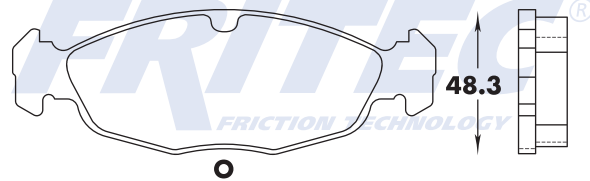
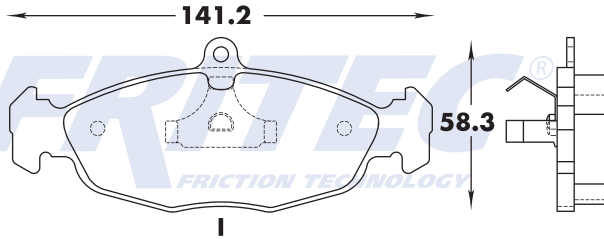

221

7566-Z1 D855

D/F	T/R	E/T
X		16.4

7566-Z1 D855

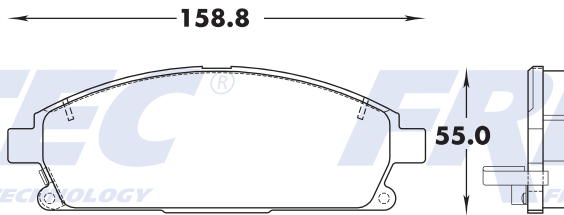

222

7569-Z D694

D/F	T/R	E/T
X		18.7, 18.9

7569-Z D694

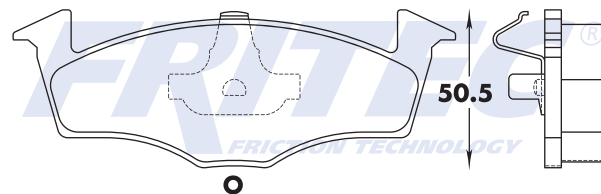
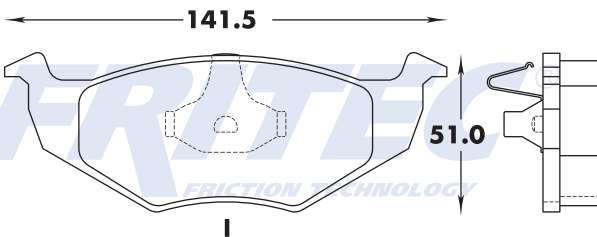

223

756X-Z D694

D/F	T/R	E/T
X		15.5

756X-Z D694

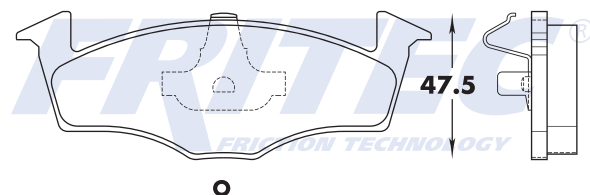
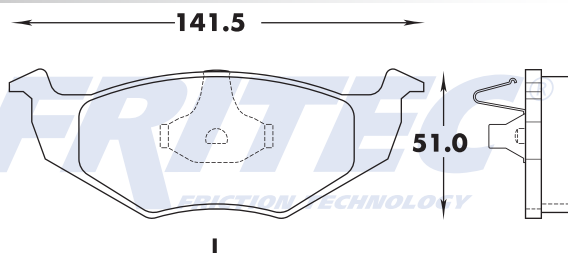

224

7572-Z D684

D/F	T/R	E/T
X		18.5

7572-Z D684

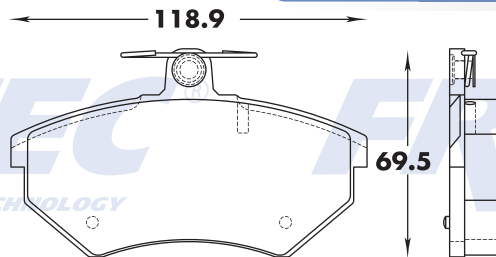

225

7573-Z D465

D/F	T/R	E/T
X		15.9

7573-Z D465

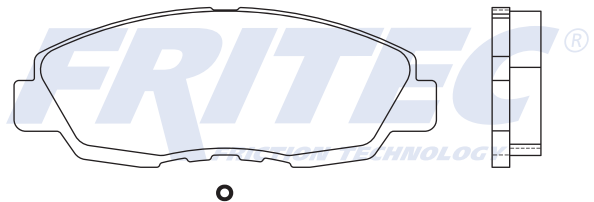
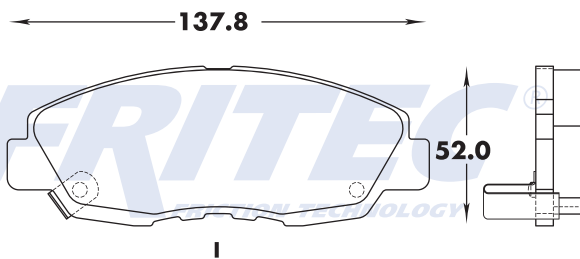

226

7574-Z D699

D/F	T/R	E/T
X		17.0

7574-Z D699

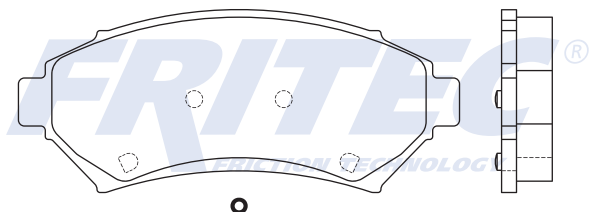
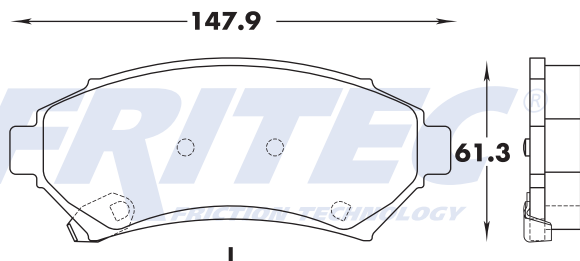

227

7576-Z D702

D/F	T/R	E/T
X		16.5

7576-Z D702

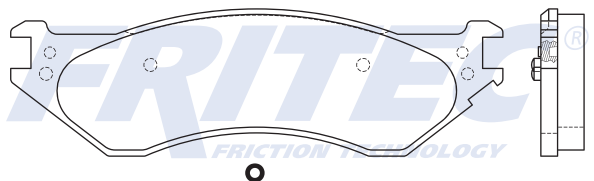
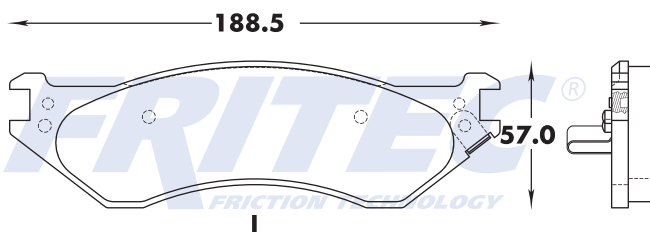

228

7578-Z D704

D/F	T/R	E/T
X		15.2

7578-Z D704

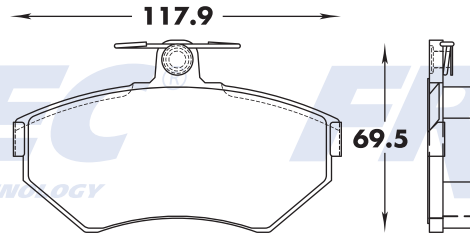

229

7582-Z D709

D/F	T/R	E/T
X		16.6

7582-Z D709

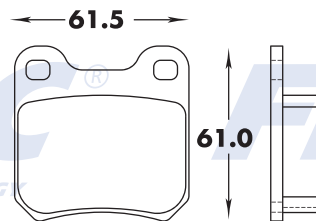

230

7584-Z D711

D/F	T/R	E/T
X		16.0

7584-Z D711

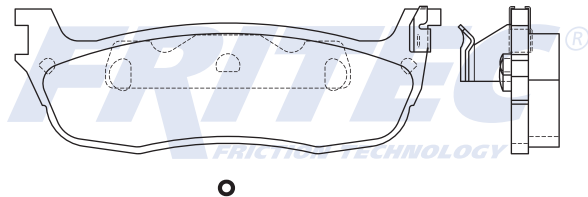
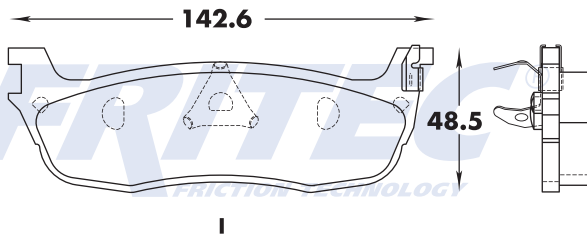

231

7584-Z1 D879

D/F	T/R	E/T
X		16.0

7584-Z1 D879

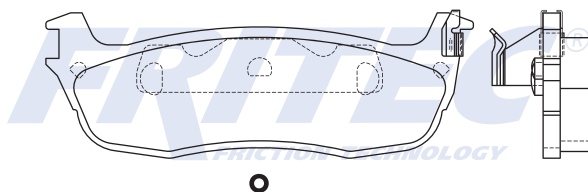
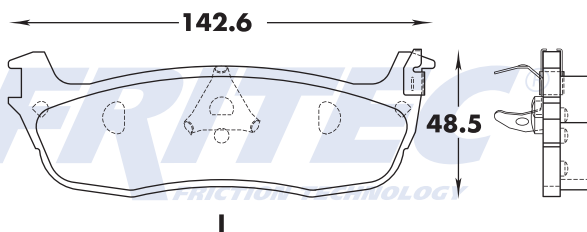

232

7585-Z D579

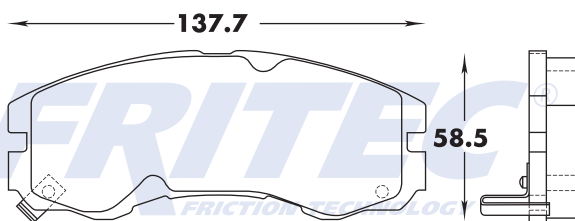

I

D/F	T/R	E/T
X		15.5

7585-Z D579

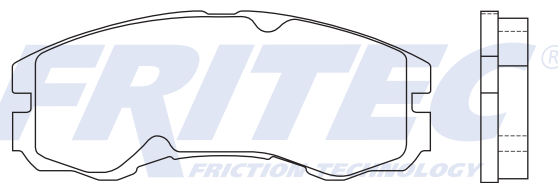

O

233

7592-Z D946

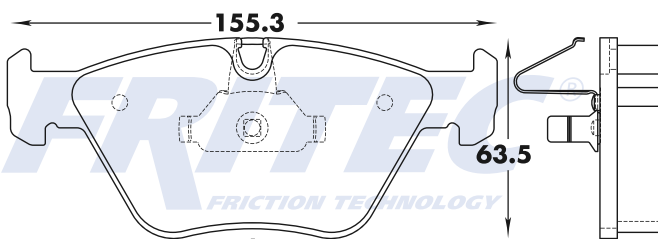

I

D/F	T/R	E/T
X		19.4

7592-Z D946

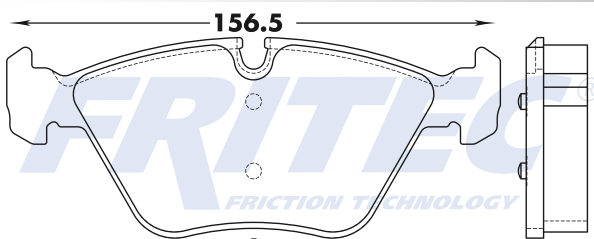

O

234

7593-Z D726

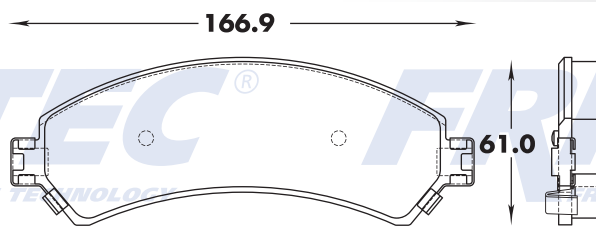

D/F	T/R	E/T
X		15.2

7593-Z D726

235

7594-Z D727

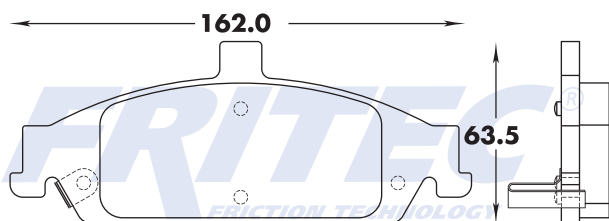

I

D/F	T/R	E/T
X		16.6, 16.8

7594-Z D727

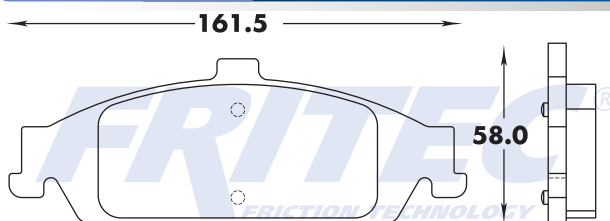

O

236

7595-Z D728

D/F	T/R	E/T
X		16.8

7595-Z D728

127.8

49.3

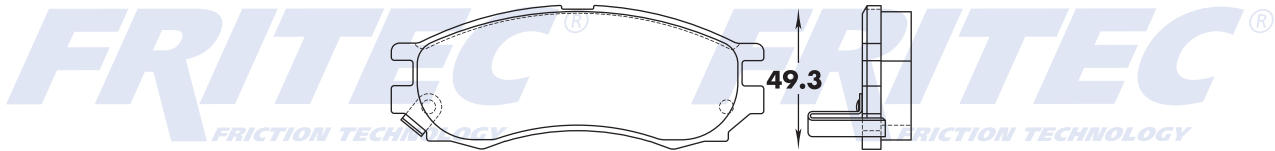

237

7596-Z D729

D/F	T/R	E/T
X		15.5

7596-Z D729

142.6

46.8

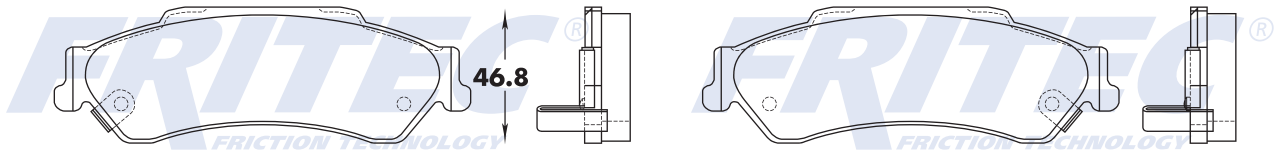

I

O

238

8342-D1221

D/F	T/R	E/T
X		18.2

8342-D1221

x 4 130.0

56.5

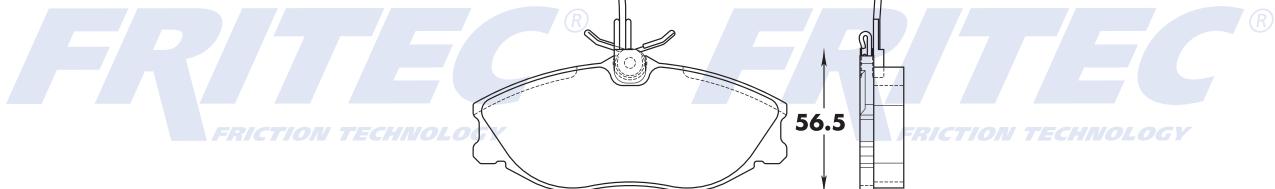

239

75X6-Z F093

D/F	T/R	E/T
X		18.0

75X6-Z F093

151.3

46.0

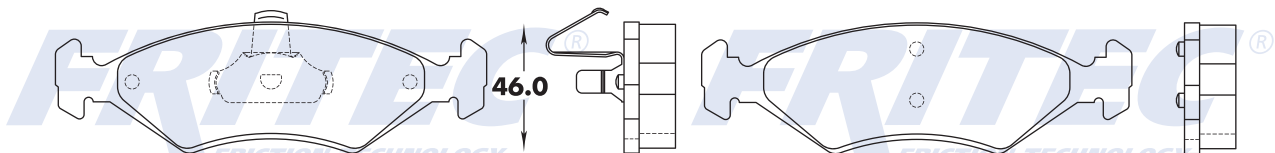

I

O

240

75X9-Z F062

D/F	T/R	E/T
X		16.6

75X9-Z F062

141.2

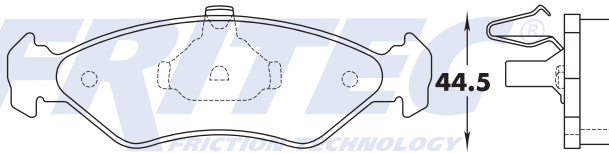

I

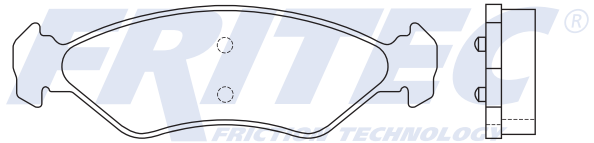

O

241

9061-D1830

D/F	T/R	E/T
X		17.3

9061-D1830

140.0

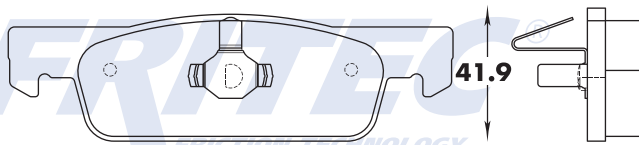

I

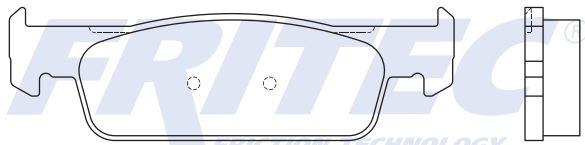

O

242

7610-Z D674

D/F	T/R	E/T
X		16.0

7610-Z D674

140.3

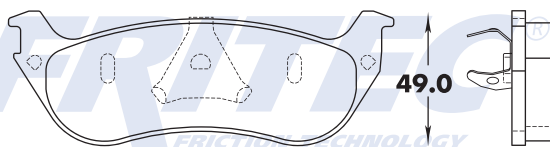

I

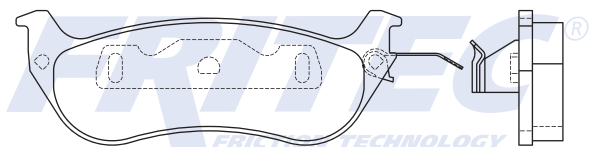

O

243

7611-Z D741

D/F	T/R	E/T
X		16.5

7594-Z D727

116.5

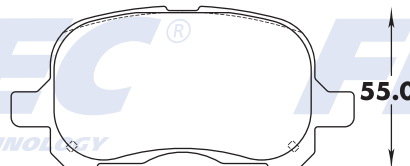

55.0



244

7614-Z D709

D/F	T/R	E/T
X		14.9

7614-Z D709

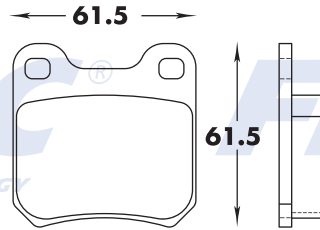

245

7616-Z D746

D/F	T/R	E/T
X		20.2

7616-Z D746

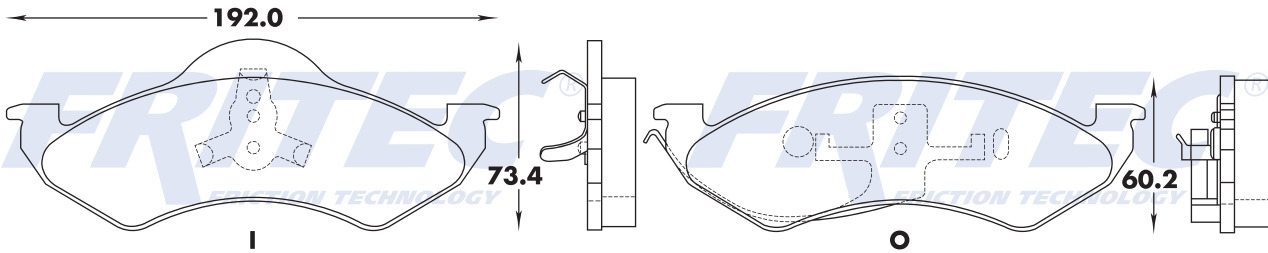

246

7616-Z1 D820

D/F	T/R	E/T
X		20.2

7616-Z1 D820

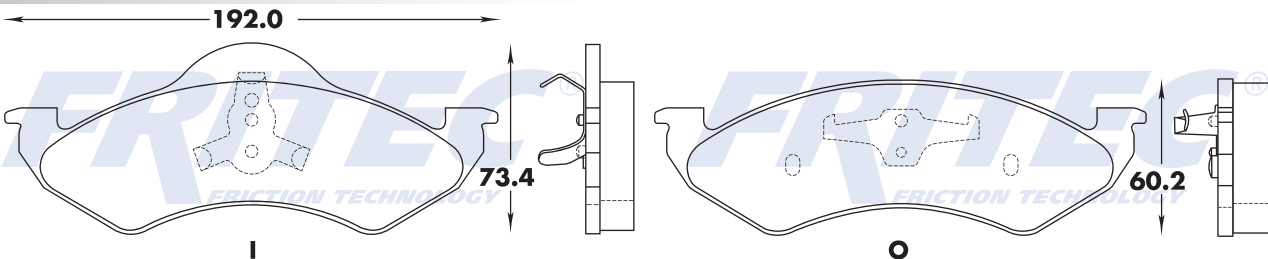

247

7617-Z D748

D/F	T/R	E/T
X		16.4

7617-Z D748

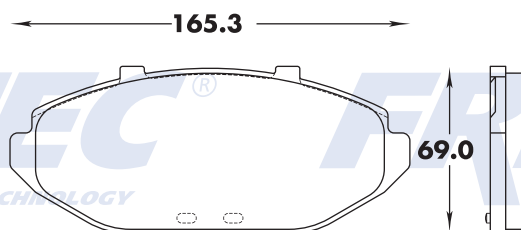

248

7618-Z D749

D/F	T/R	E/T
X		14.7

7618-Z D749

182.6

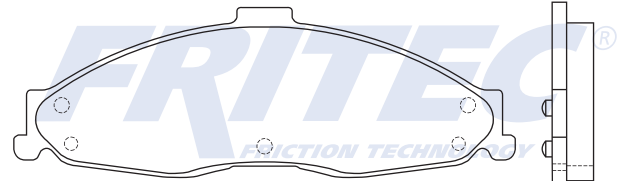
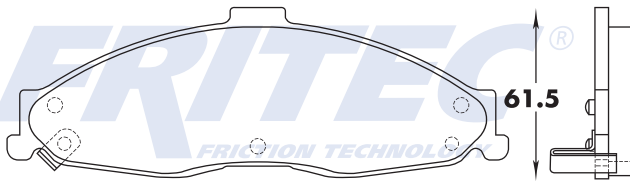

249

7619-Z D750

D/F	T/R	E/T
X		16.6

7619-Z D750

121.3

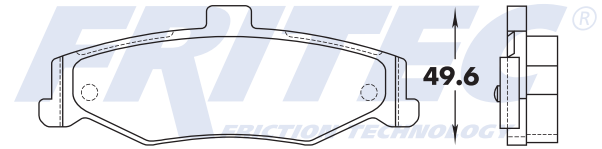
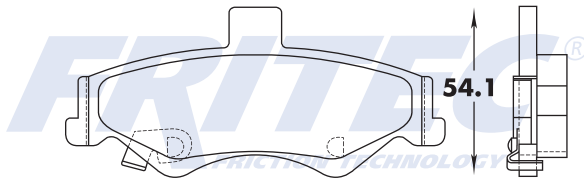

250

7620-Z D752

D/F	T/R	E/T
X		16.1

7620-Z D752

162.0

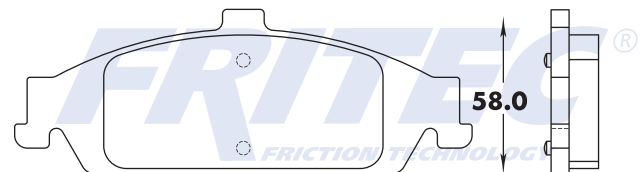
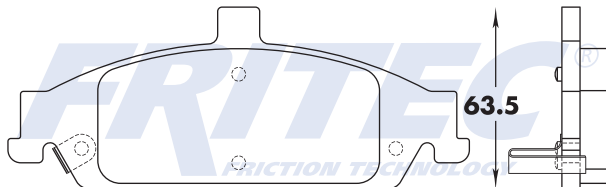

251

7623-Z D730

D/F	T/R	E/T
X		17.0, 14.9

7623-Z D730

164.0

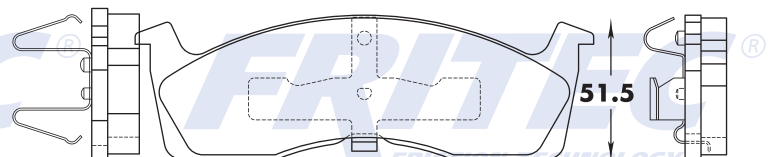
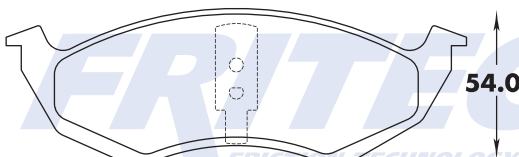

252

7625-Z1 D824

D/F	T/R	E/T
X		17.8

7625-Z1 D824

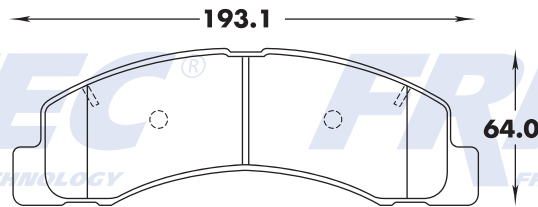

253

7626-Z D757

D/F	T/R	E/T
X		17.4

7626-Z D757

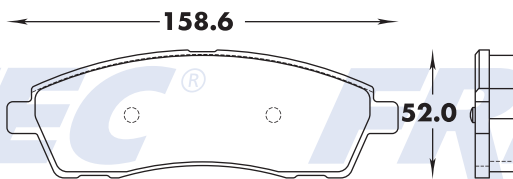

254

7627-Z D758

D/F	T/R	E/T
X		15.7

7627-Z D758

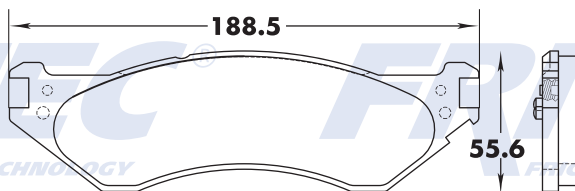

255

7628-Z D760

D/F	T/R	E/T
X		16.7, 15.7

7628-Z D760

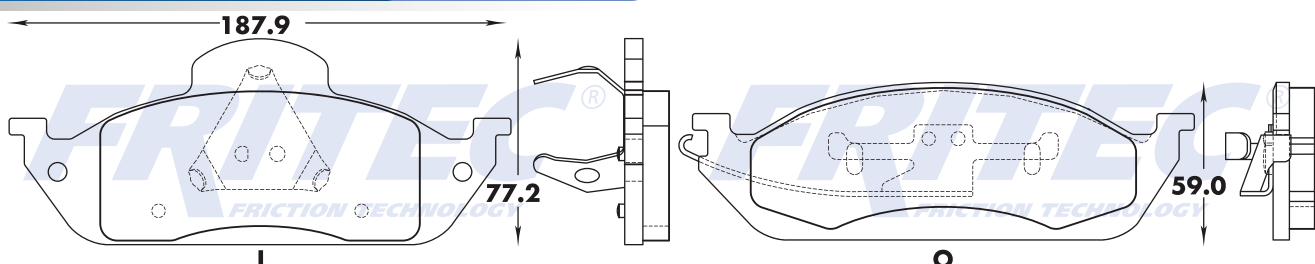

256

7632-Z D764

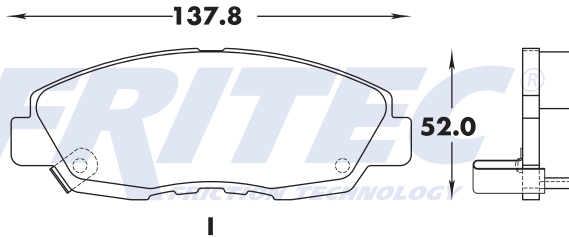

D/F	T/R	E/T
X		16.8

7632-Z D764

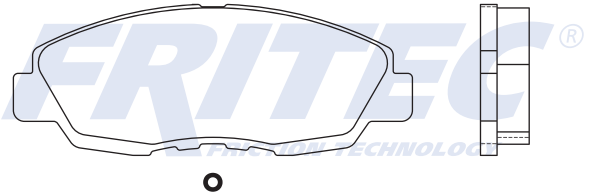

257

7634-Z D767

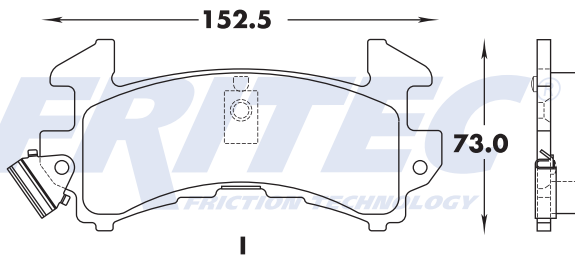

D/F	T/R	E/T
X		13.7, 13.5

7634-Z D767

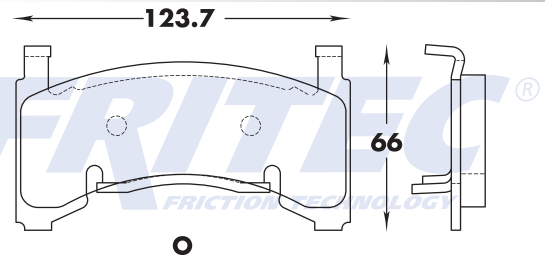

258

7635-Z D768

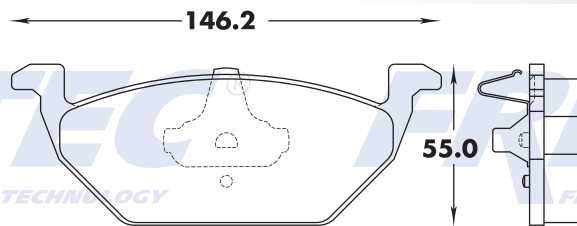

D/F	T/R	E/T
X		19.1

7635-Z D768

259

7636-Z D1032

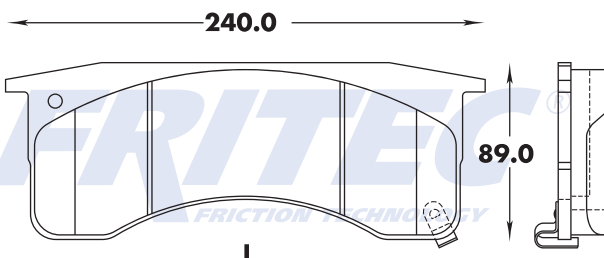

D/F	T/R	E/T
X		25.2

7636-Z D1032

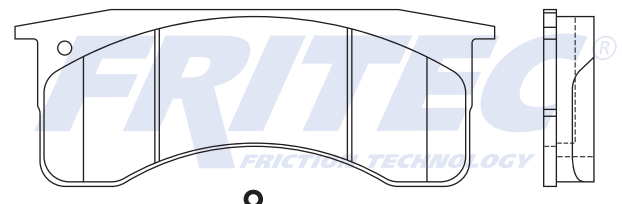

260

7637-Z D770

D/F	T/R	E/T
X		13.8

7637-Z D770

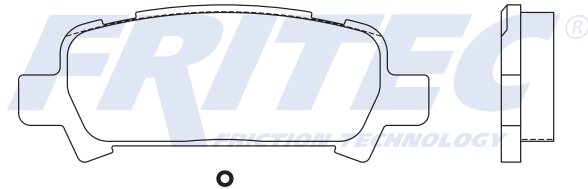
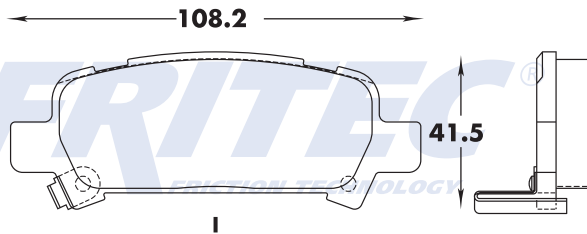

261

7639-Z D772

D/F	T/R	E/T
X		17.4

7639-Z D772

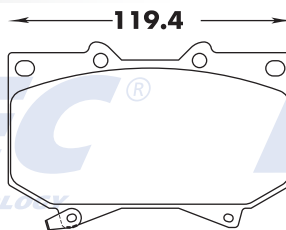

262

7644-Z D777

D/F	T/R	E/T
X		20.7

7644-Z D777

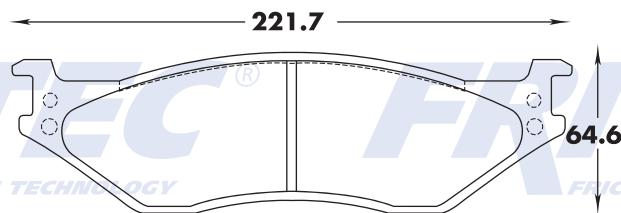

263

7647-Z D779

D/F	T/R	E/T
X		14.3

7647-Z D779

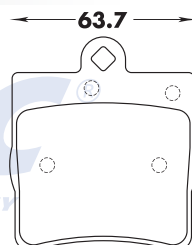

264

7649-Z D781

D/F	T/R	E/T
X		16.6, 16.8

7649-Z D781

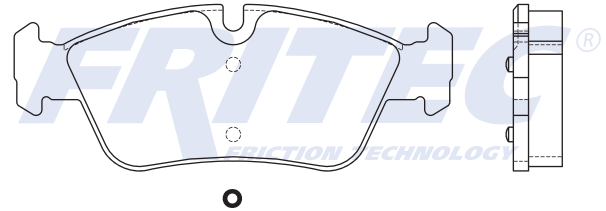
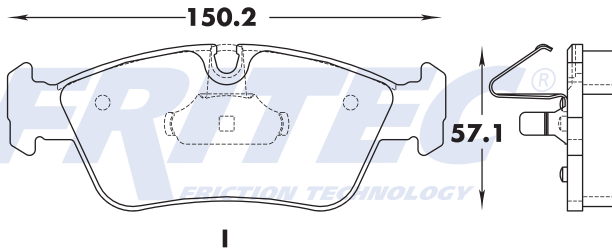

265

8661-Z D1461

D/F	T/R	E/T
X		15.7

8661-Z D1461

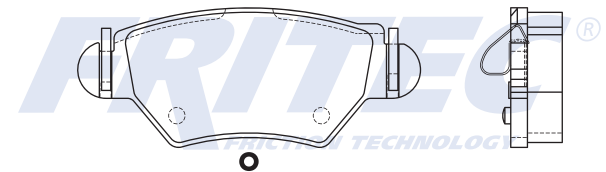
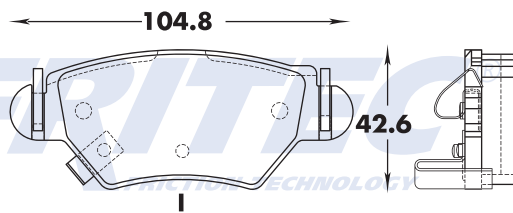

266

7652-Z D784

D/F	T/R	E/T
X		18.0

7652-Z D784

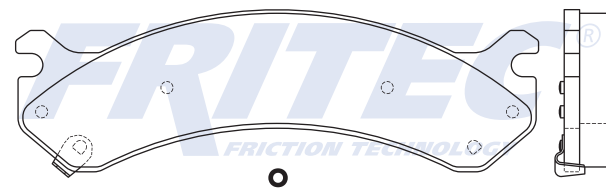
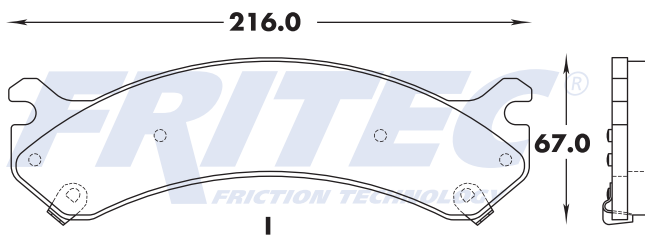

267

7653-Z D785

D/F	T/R	E/T
X		18.3

7653-Z D785

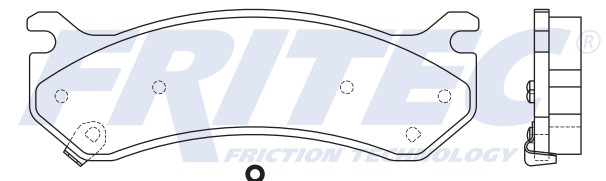
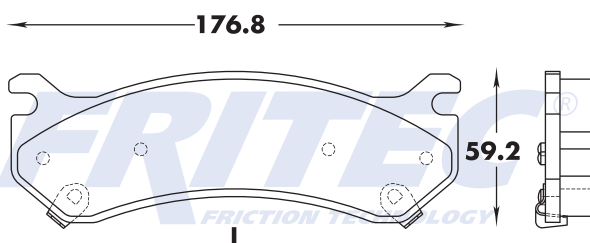

268

7656-Z1 D1506

D/F	T/R	E/T
X		17.3

7656-Z1 D1506

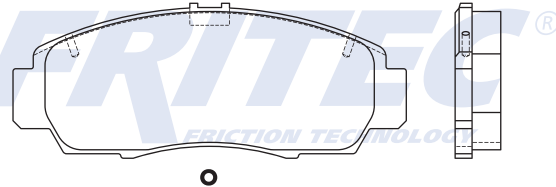
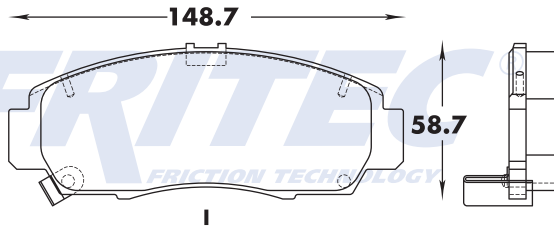

269

7658-Z D788

D/F	T/R	E/T
X		14.6

7658-Z D788

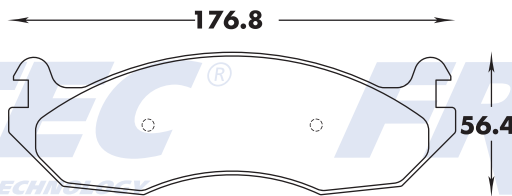

270

7659-Z D789

D/F	T/R	E/T
X		16.6, 15.7

7659-Z D789

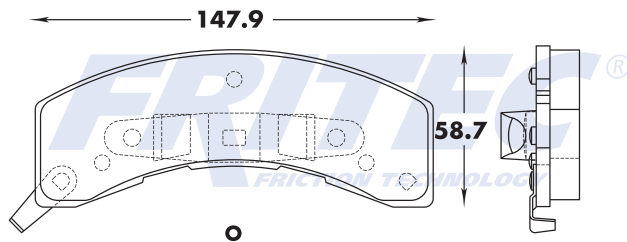
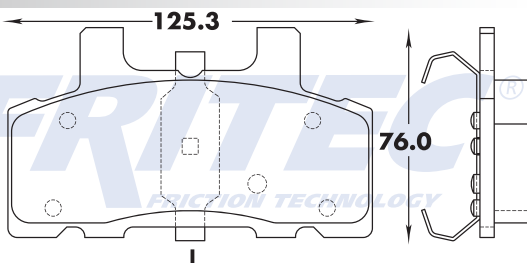

271

765X-Z F157

D/F	T/R	E/T
X		15.0

765X-Z F157

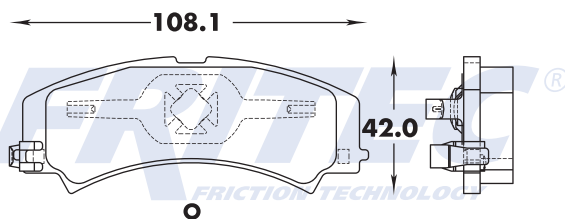
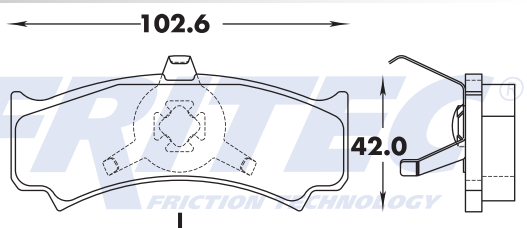

272

7660-Z D790

D/F	T/R	E/T
X		17.8

7660-Z D790

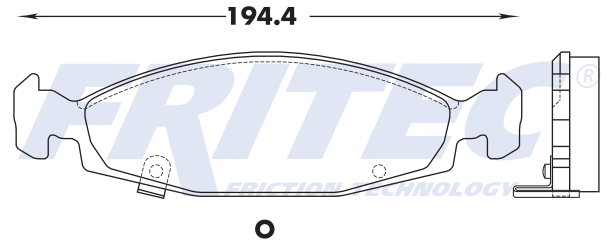
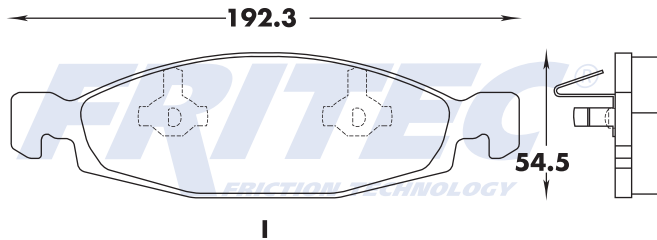

273

7661-Z D791

D/F	T/R	E/T
X		16.8

7661-Z D791

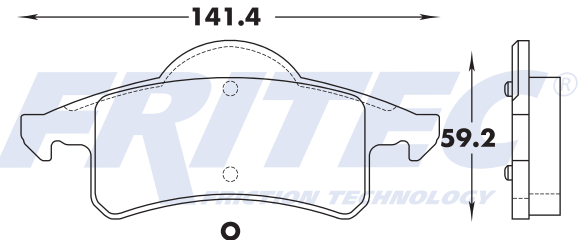
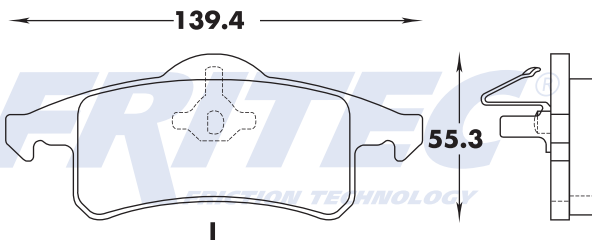

274

7662-Z D792

D/F	T/R	E/T
X		17.1

7662-Z D792

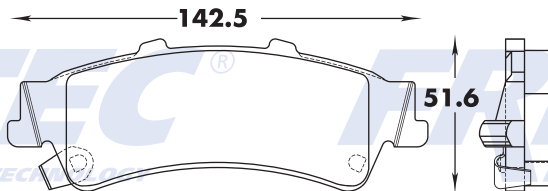

275

7663-Z D793

D/F	T/R	E/T
X		17.0

7663-Z D793

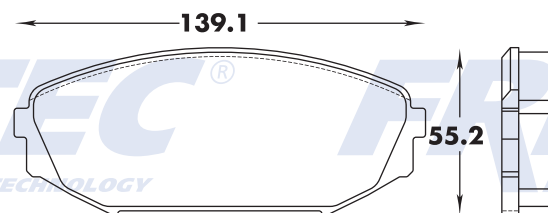

276

7664-Z D794

D/F	T/R	E/T
X		17.7, 17.8

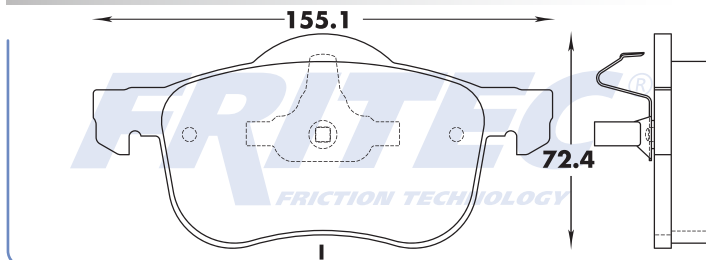

7664-Z D794

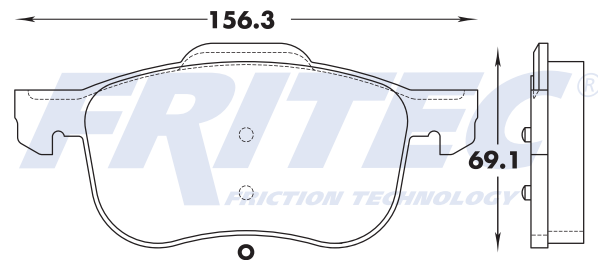

277

7665-Z D795

D/F	T/R	E/T
X		16.3

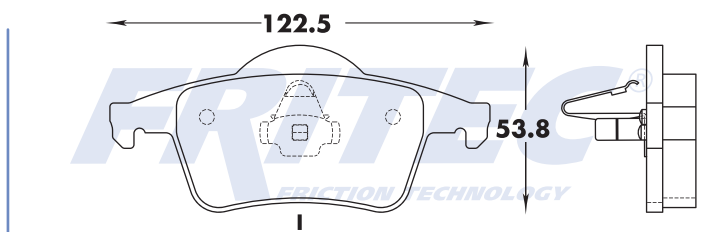

7665-Z D795

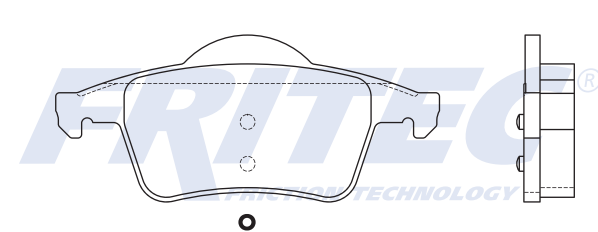

278

766X-Z F186

D/F	T/R	E/T
X		16.5

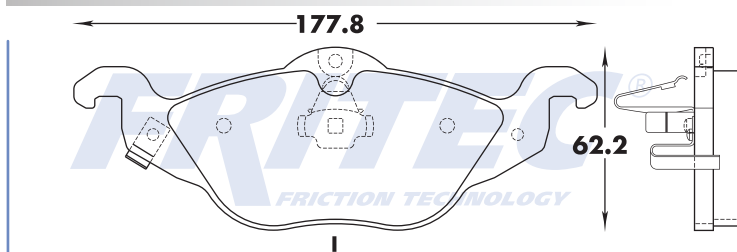

766X-Z F186

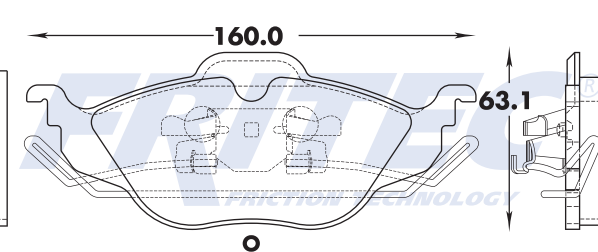

279

766X-AZ F186

D/F	T/R	E/T
X		16.5

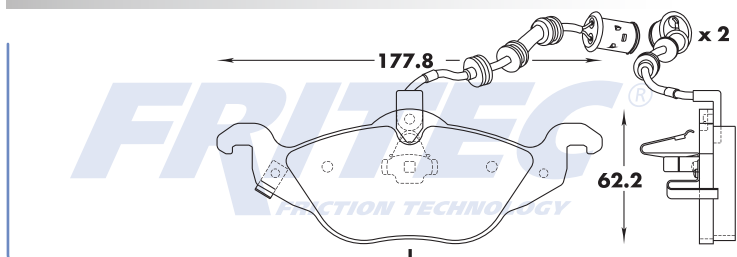

766X-AZ F186

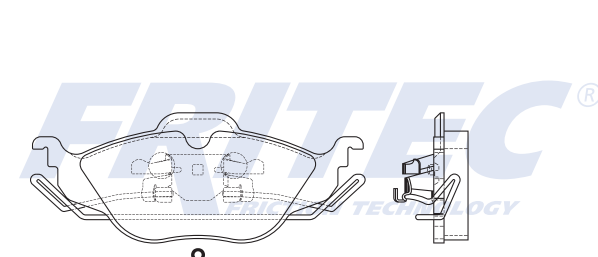

280

8308-Z D1189

D/F	T/R	E/T
X		17.3

8308-Z D1189

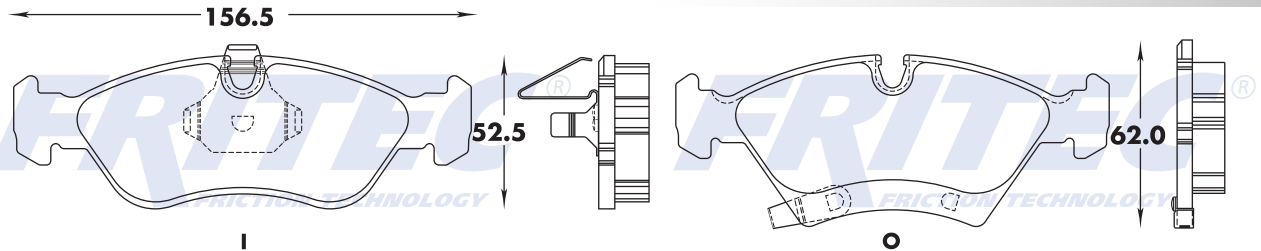

281

7670-Z D798

D/F	T/R	E/T
X		15.4

7670-Z D798

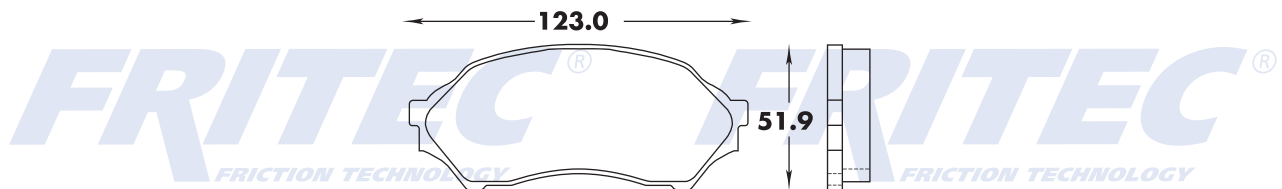

282

7671-Z D799

D/F	T/R	E/T
X		17.0

7671-Z D799

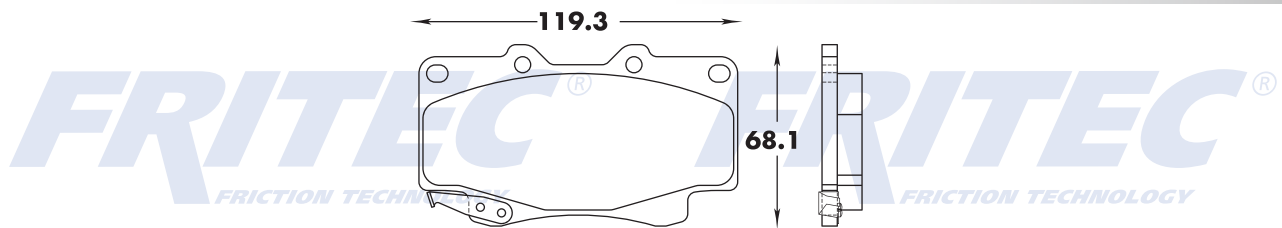

283

7672-AZ D801

D/F	T/R	E/T
X		18.0

7672-AZ D801

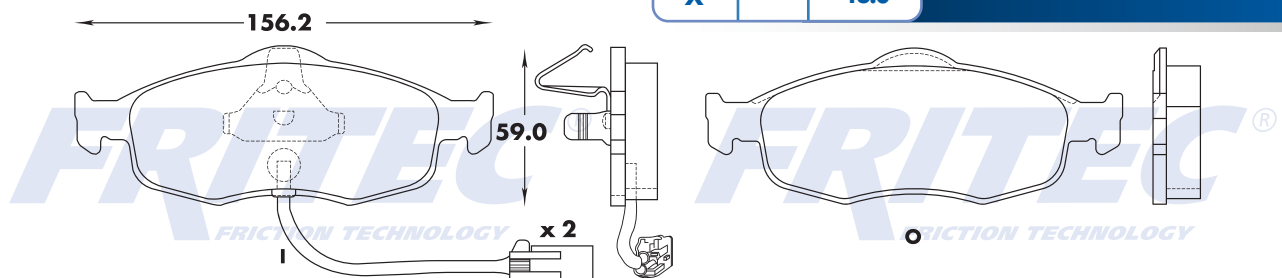

284

7673-Z D802

D/F	T/R	E/T
X		16.6

7673-Z D802

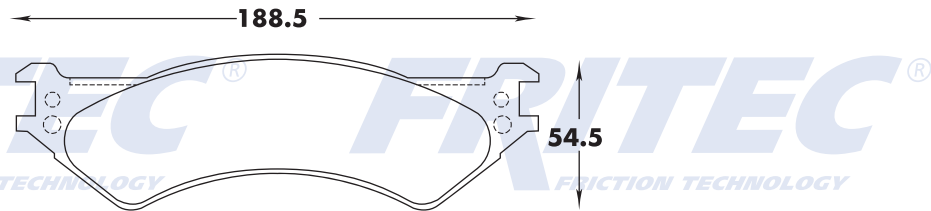

285

7674-Z D803

D/F	T/R	E/T
X		17.8

7674-Z D803

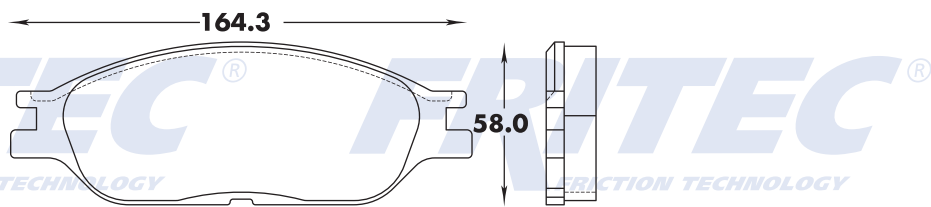

286

7675-Z D804

D/F	T/R	E/T
X		15.5

7675-Z D804

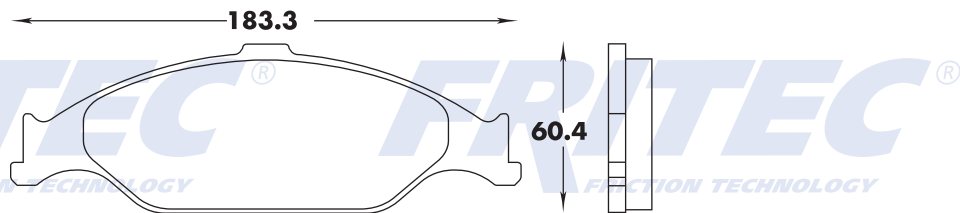

287

7676-Z D805

D/F	T/R	E/T
X		16.9

7676-Z D805

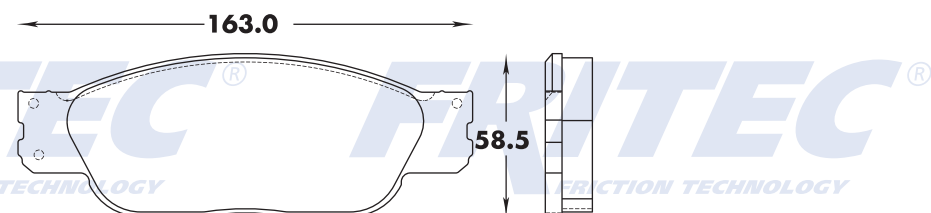

288

7677-Z D655

D/F	T/R	E/T
X		17.9

7677-Z D655

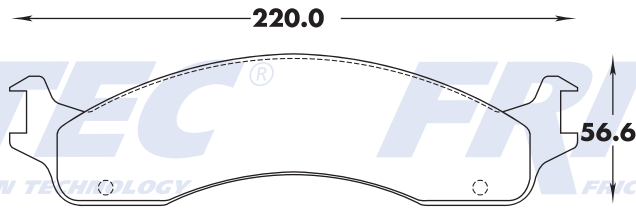

289

7680-Z D807

D/F	T/R	E/T
X		14.9

7680-Z D807

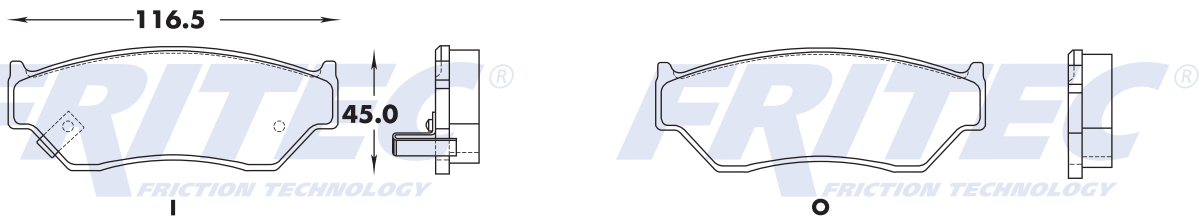

290

7681-Z D808

D/F	T/R	E/T
X		16.0

7681-Z D808

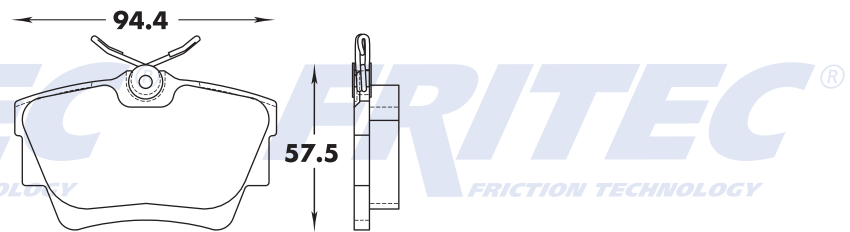

291

7681A-Z D808

D/F	T/R	E/T
X		16.0

7681A-Z D808

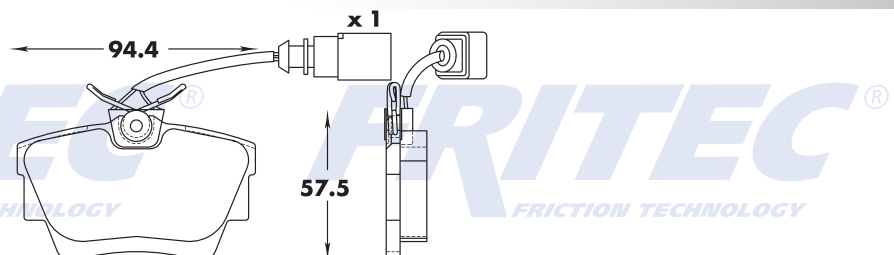

292

7687-Z D812

D/F	T/R	E/T
X		16.9

7687-Z D812

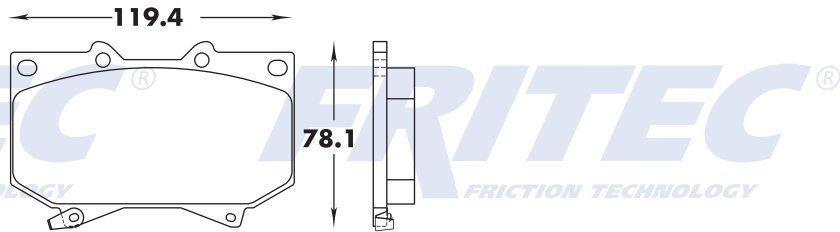

293

8725-Z D1516

D/F	T/R	E/T
X		19.0

8725-Z D1516

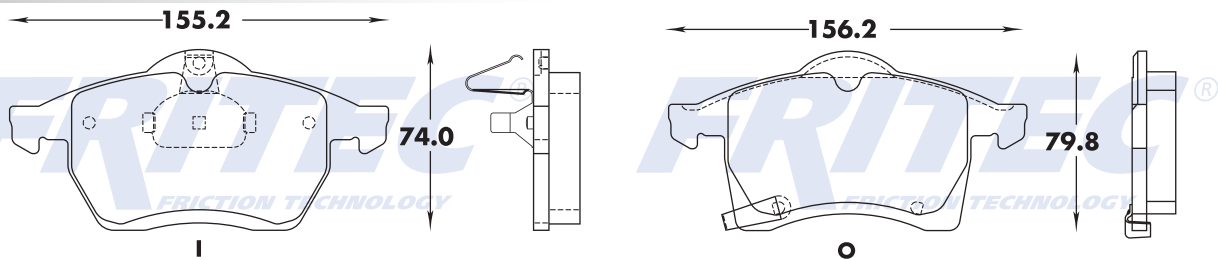

294

768X-AZ F185

D/F	T/R	E/T
X		19.1

768X-AZ F185

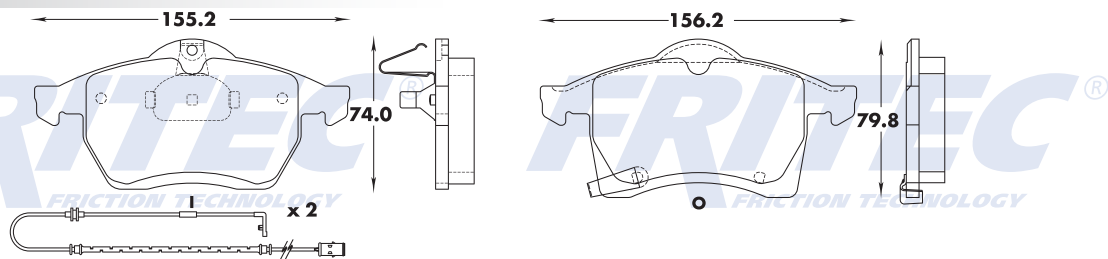

295

7690-AZ D816

D/F	T/R	E/T
X		18.2

7690-AZ D816

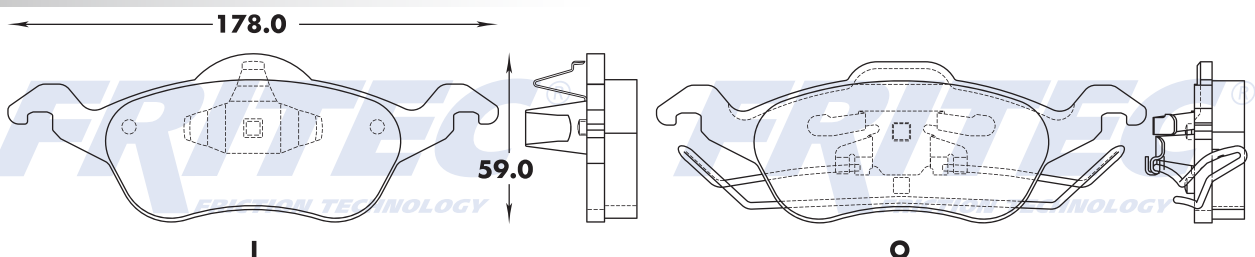

296

7690-Z D816

D/F	T/R	E/T
X		18.2

7690-Z D816

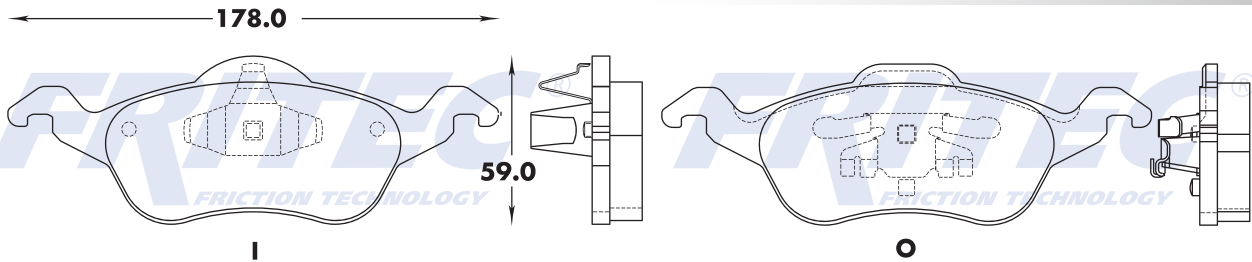

297

7693-Z D818

D/F	T/R	E/T
X		17.0

7693-Z D818

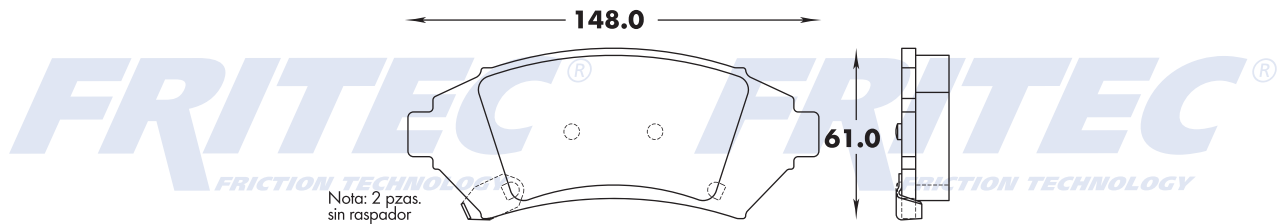

298

7694-Z D821

D/F	T/R	E/T
X		18.7

7694-Z D821

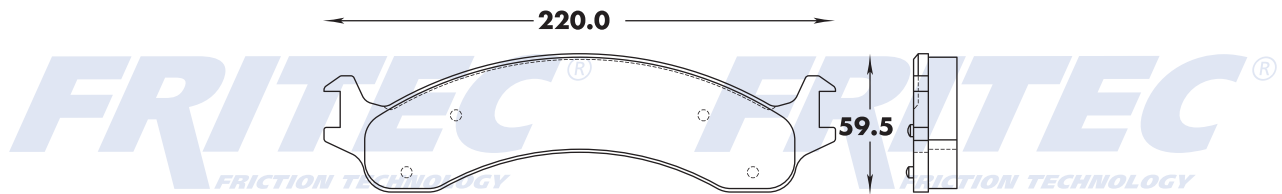

299

7694-Z1 D859

D/F	T/R	E/T
X		18.7

7694-Z1 D859

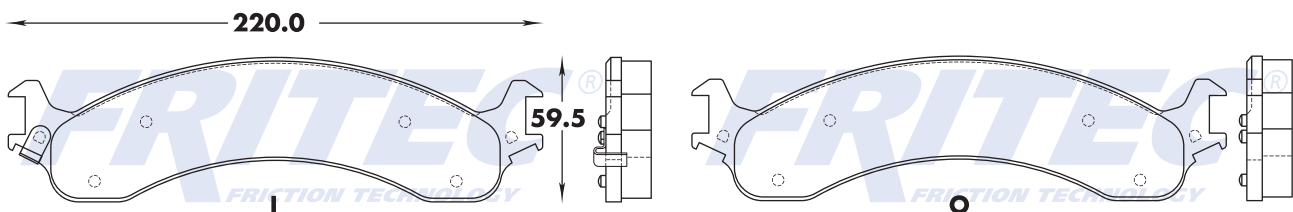

300

7695-Z D822

D/F	T/R	E/T
X		16.4

7695-Z D822

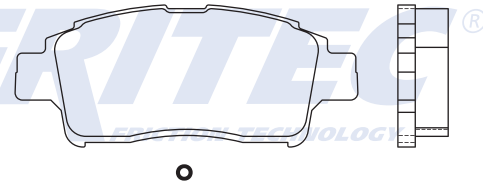
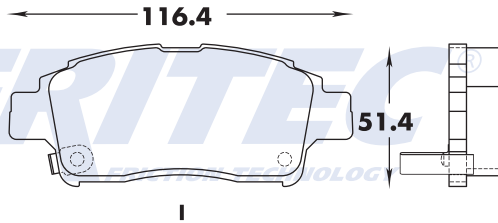

301

7697-Z D825

D/F	T/R	E/T
X		19.8

7697-Z D825

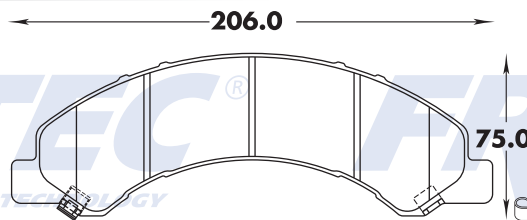

NOTA: 2 PZAS. C/RASPADOR

302

8660-Z D1460

D/F	T/R	E/T
X		17.5

8660-Z D1460

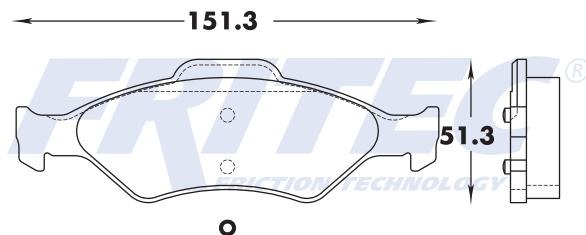
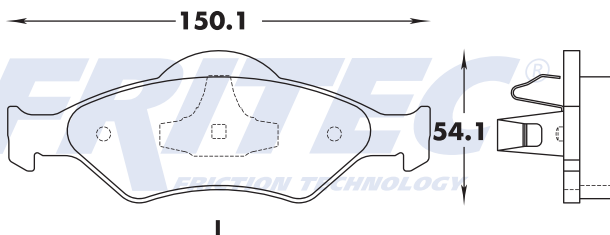

303

8254-Z D1499

D/F	T/R	E/T
X		18.0

8254-Z D1499

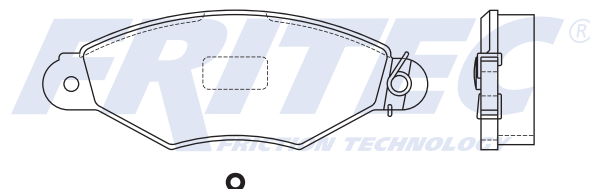
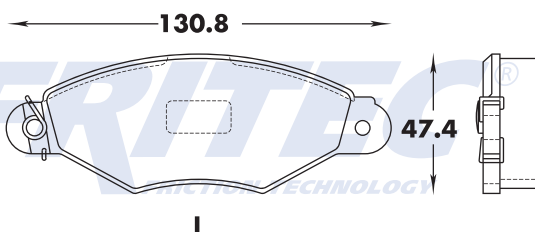

304

76X1A-Z F128

D/F	T/R	E/T
X		18.0

76X1A-Z F128

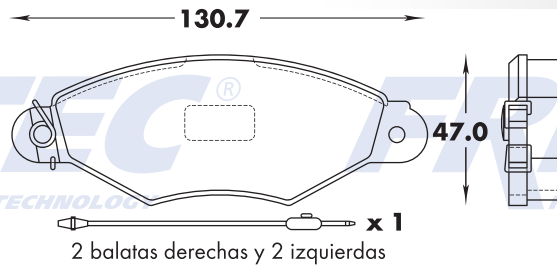

305

76X3-Z F134

D/F	T/R	E/T
X		18.0

76X3-Z F134

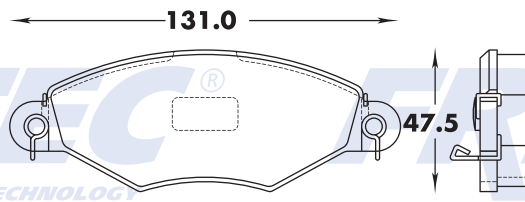

306

7700-Z D792

D/F	T/R	E/T
X		16.3

7700-Z D792

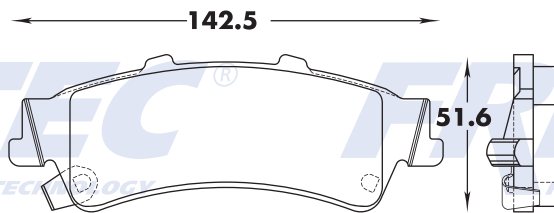

307

7701-Z D828

D/F	T/R	E/T
X		15.4

7701-Z D828

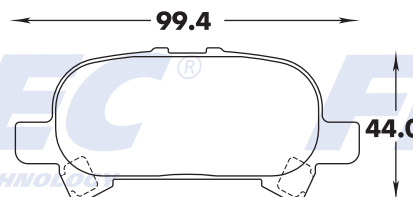

308

7702-Z D829

D/F	T/R	E/T
X		15.9

7702-Z D829

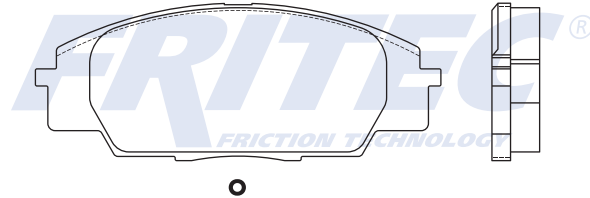
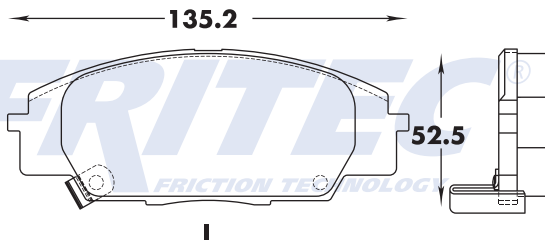

309

7703-Z D830

D/F	T/R	E/T
X		16.9

7703-Z D830

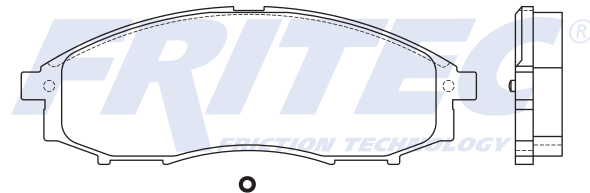
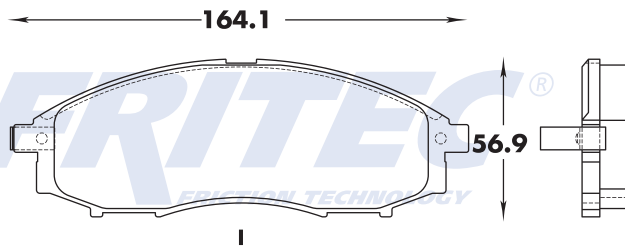

310

7704-Z D831

D/F	T/R	E/T
X		16.5

7704-Z D831

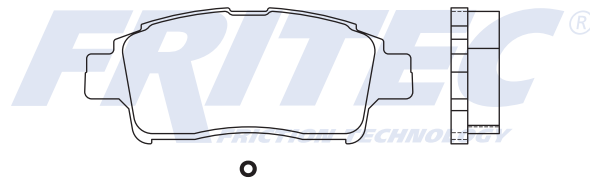
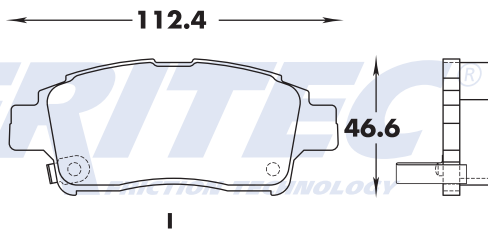

311

7706-Z D833

D/F	T/R	E/T
X		16.5

7706-Z D833

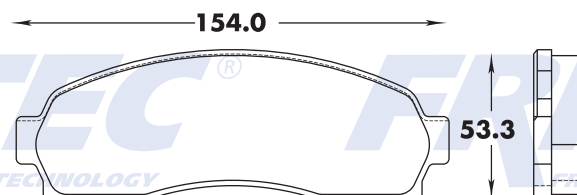

312

7707-Z D834

D/F	T/R	E/T
X		16.3

7707-Z D834

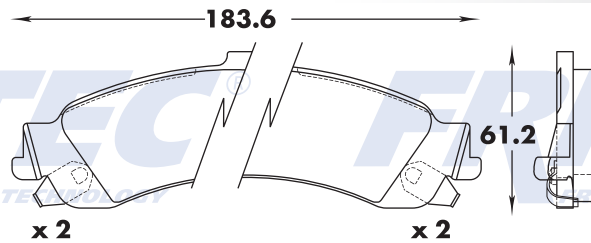

313

7709-Z D768

D/F	T/R	E/T
X		18.5

7709-Z D768

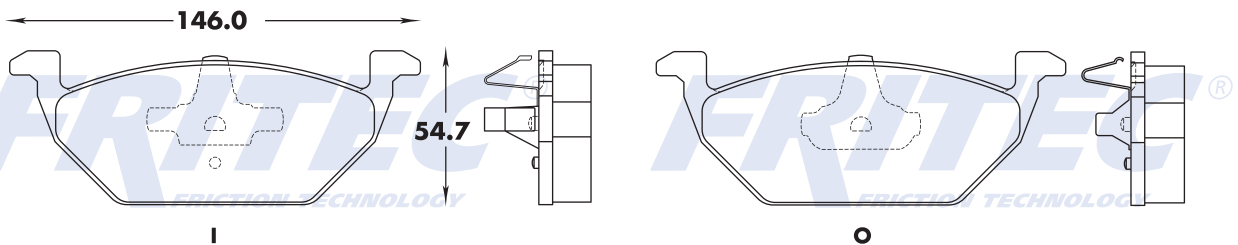

314

7709-AZ D768

D/F	T/R	E/T
X		18.5

7709-AZ D768

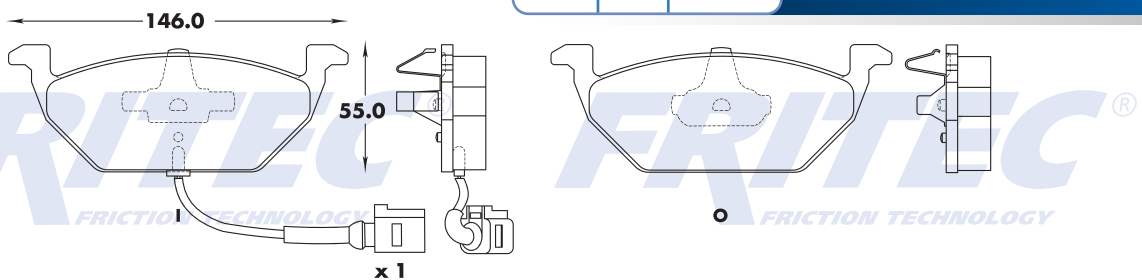

315

7710-Z D687

D/F	T/R	E/T
X		19.3

7710-Z D687

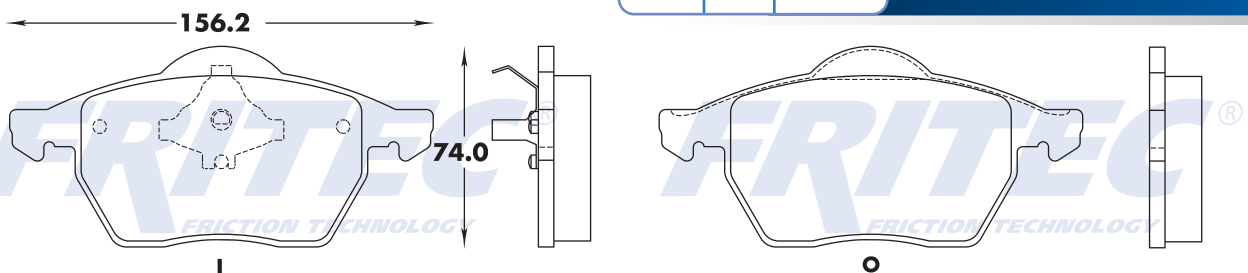

316

7710-AZ D687

D/F	T/R	E/T
X		19.3

7710-AZ D687

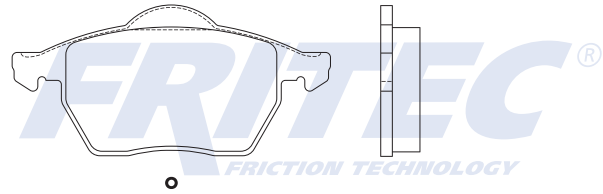
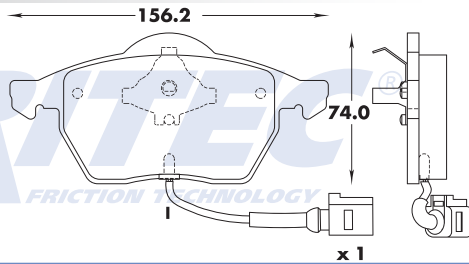

317

7712-Z D837

D/F	T/R	E/T
X		16.4

7712-Z D837

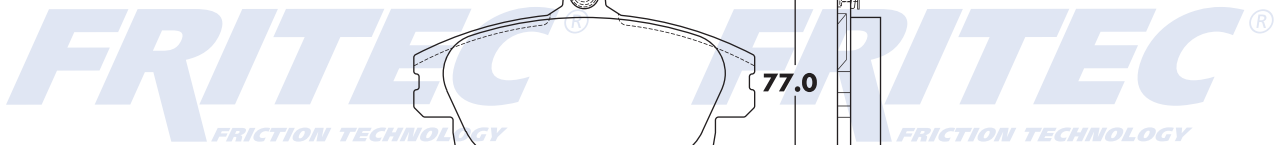
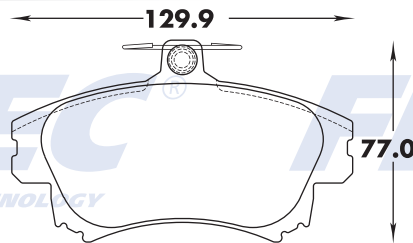

318

7713-Z D838

D/F	T/R	E/T
X		15.8

7713-Z D838

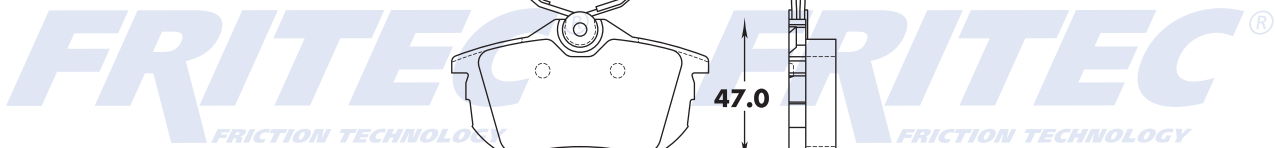
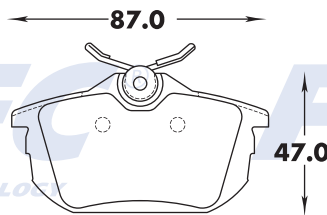

319

7715-AZ D840

D/F	T/R	E/T
X		19.3

7715-AZ D840

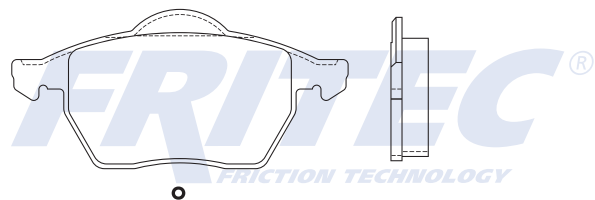
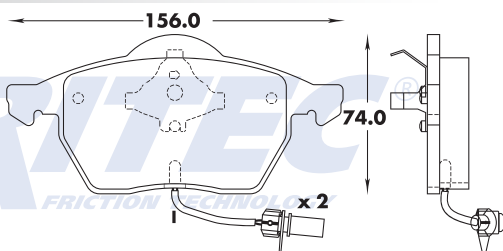

320

7716-Z D841

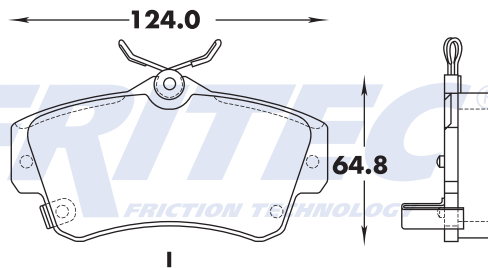

D/F	T/R	E/T
X		19.3

7716-Z D841

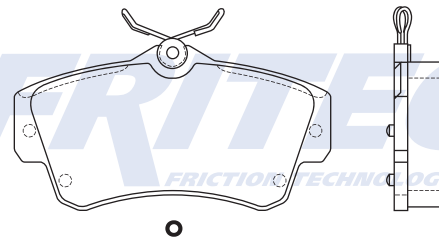

321

7718-Z D842

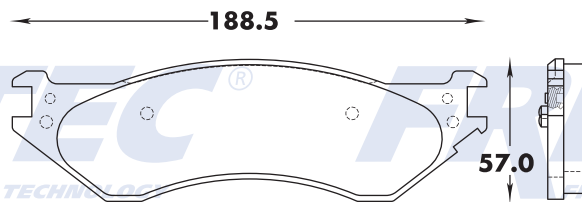

D/F	T/R	E/T
X		16.5

7718-Z D842

322

7719-Z D843

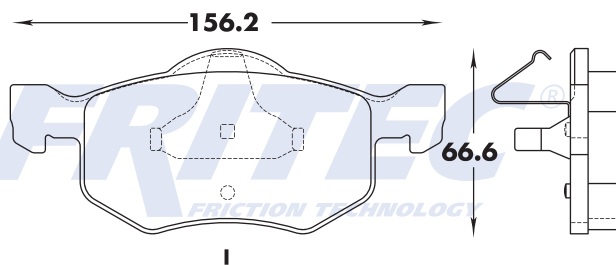

D/F	T/R	E/T
X		19.1, 18.4

7719-Z D843

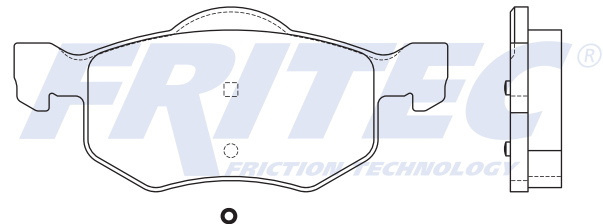

323

771X-Z F204

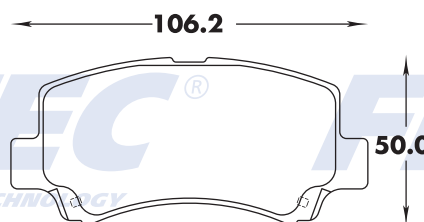

D/F	T/R	E/T
X		15.1

771X-Z F204

324

7720-Z D844

D/F	T/R	E/T
X		19.1

7720-Z D844

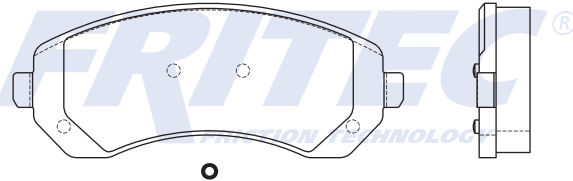
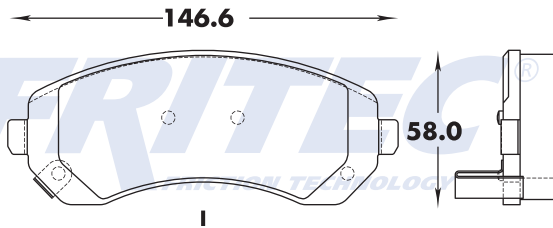

325

7723-Z D847

D/F	T/R	E/T
X		16.0

7723-Z D847

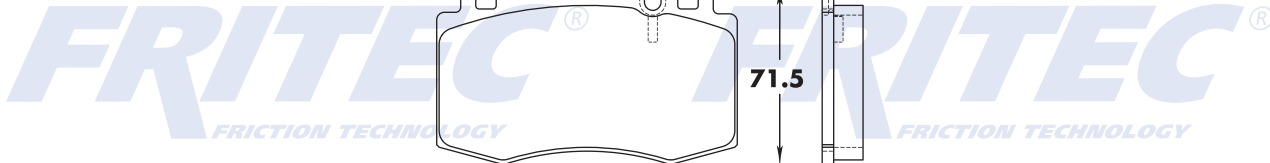
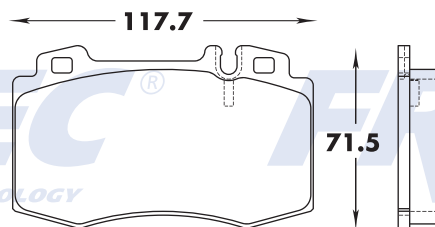

326

7725AP-Z D912

D/F	T/R	E/T
X		17.5

7725AP-Z D912

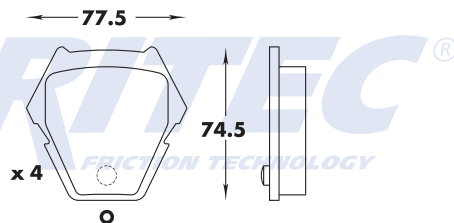
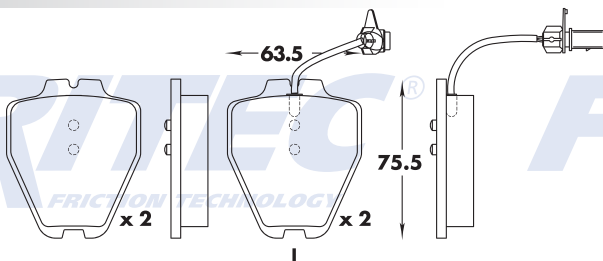

327

7725AS-Z D912

D/F	T/R	E/T
X		17.5

7725AS-Z D912

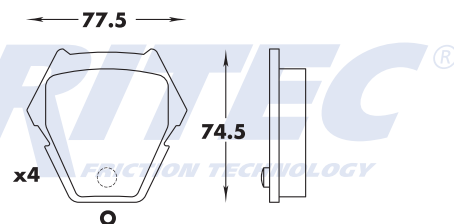
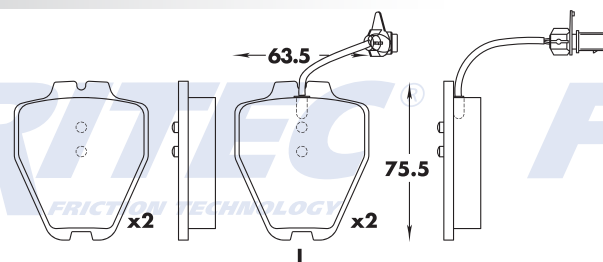

328

8257-Z D1147

D/F	T/R	E/T
X		16.1

8257-Z D1147

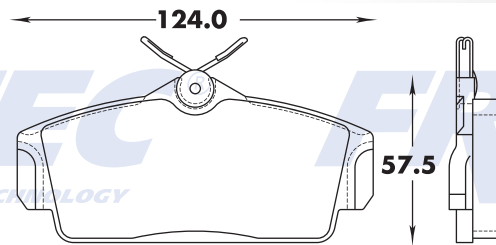

329

7730-Z D853

D/F	T/R	E/T
X		19.2

7730-Z D853

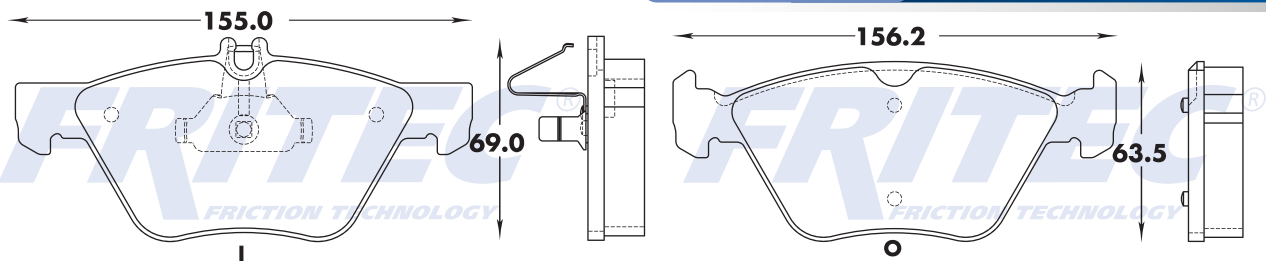

330

7732-Z D856

D/F	T/R	E/T
X		17.5

7732-Z D856

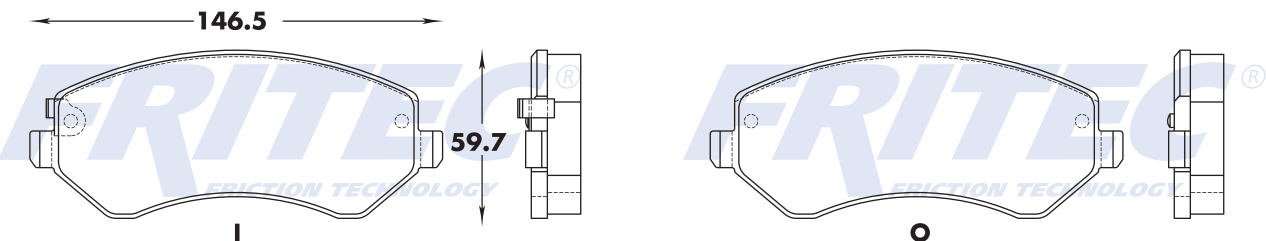

331

7733-Z D857

D/F	T/R	E/T
X		17.8

7733-Z D857

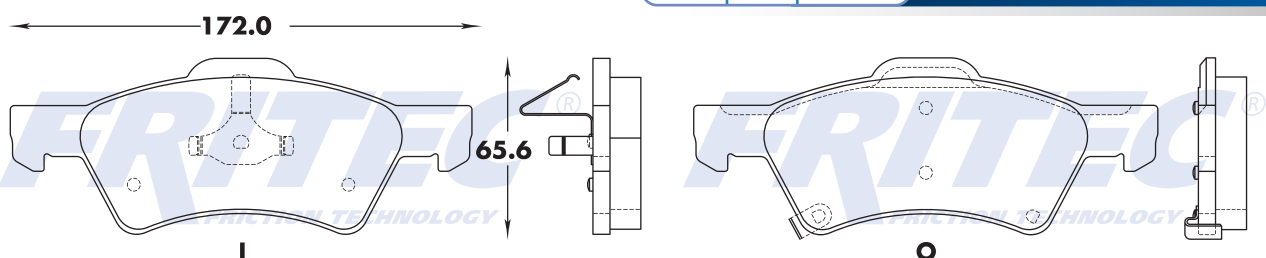

332

7734-Z D858

D/F	T/R	E/T
X		15.9

7734-Z D858

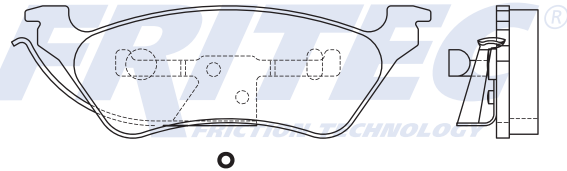
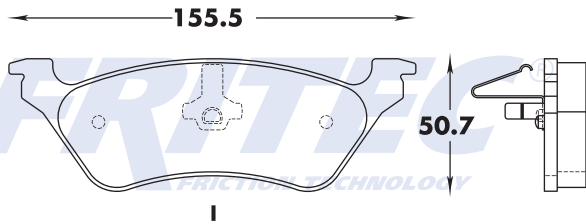

333

7735-Z D752

D/F	T/R	E/T
X		14.5

7735-Z D752

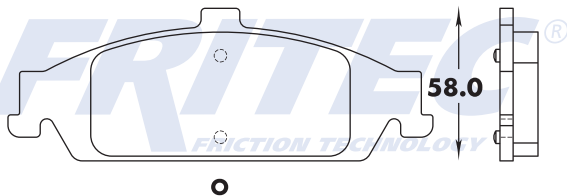
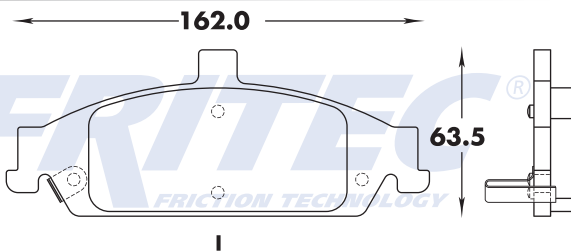

334

7738-Z D862

D/F	T/R	E/T
X		17.3

7738-Z D862

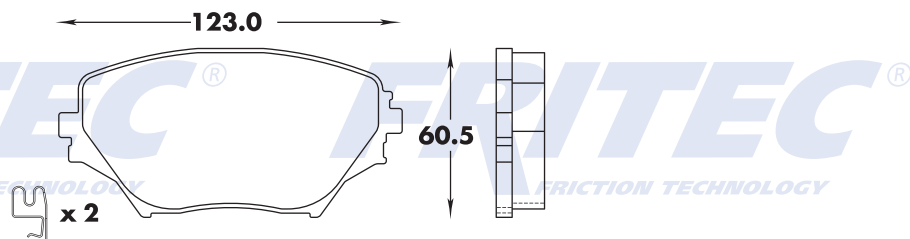

335

8305-Z D1187

D/F	T/R	E/T
X		15.0

8305-Z D1187

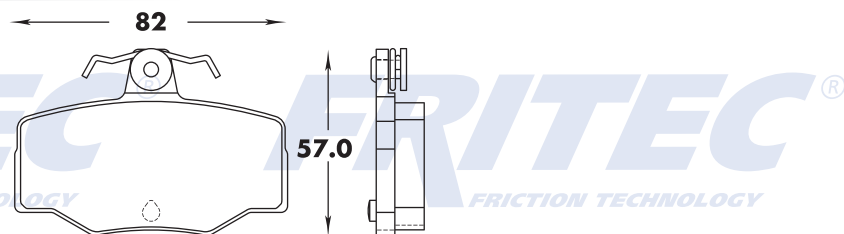

336

7740-Z D865

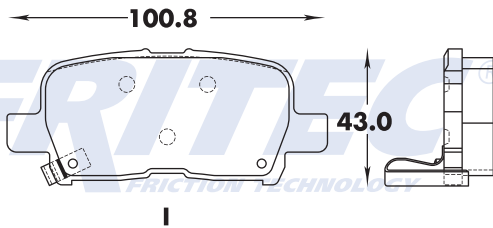

D/F	T/R	E/T
X		15.5

7740-Z D865

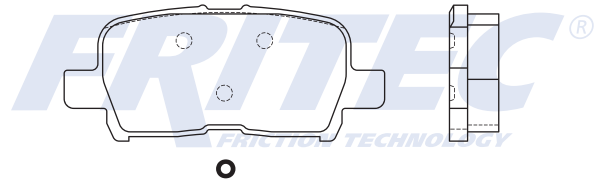

337

7741-Z D866

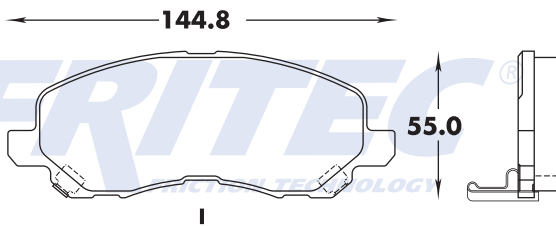

D/F	T/R	E/T
X		15.7

7741-Z D866

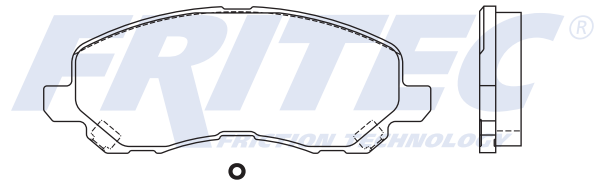

338

7742-Z D867

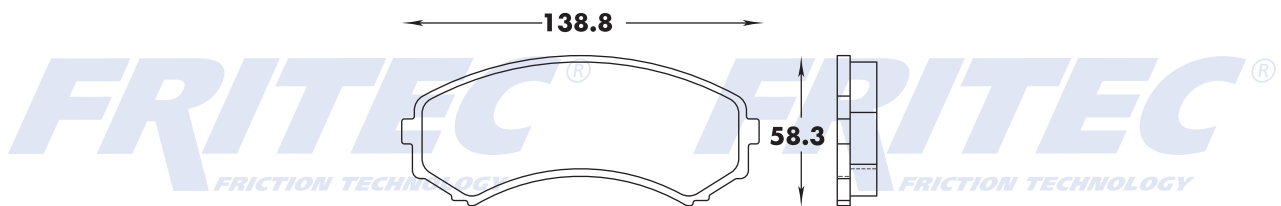

D/F	T/R	E/T
X		15.4

7742-Z D867

339

7743-Z D868

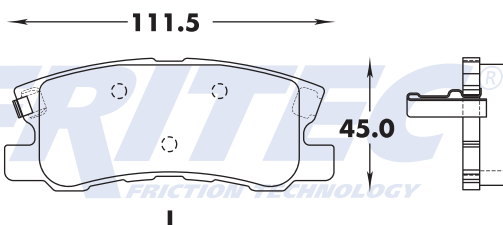

D/F	T/R	E/T
X		15.3

7743-Z D868

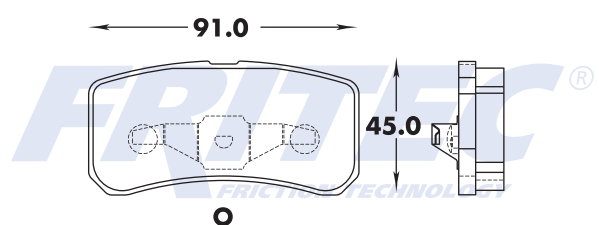

340

7744-Z D869

D/F	T/R	E/T
X		19.6

7744-Z D869

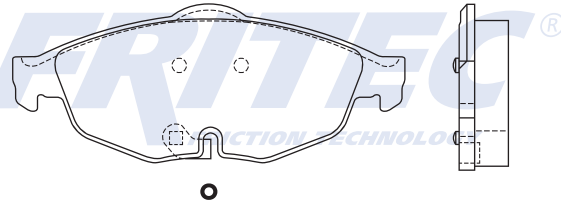
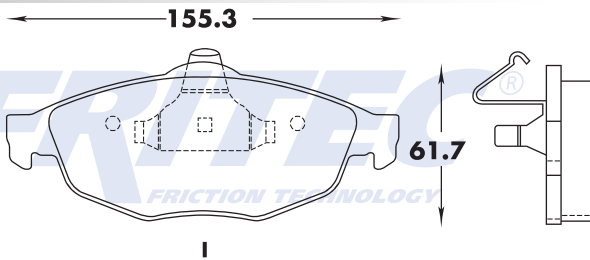

341

7747-Z D872

D/F	T/R	E/T
X		18.2

7747-Z D872

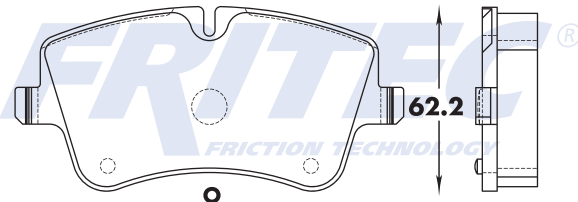
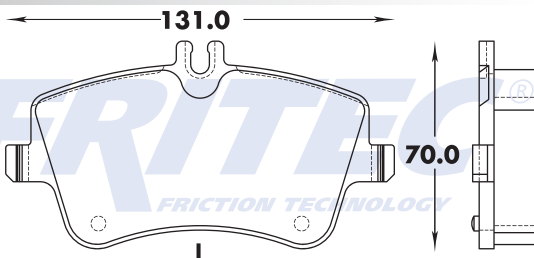

342

7748-Z D873

D/F	T/R	E/T
X		13.5

7748-Z D873

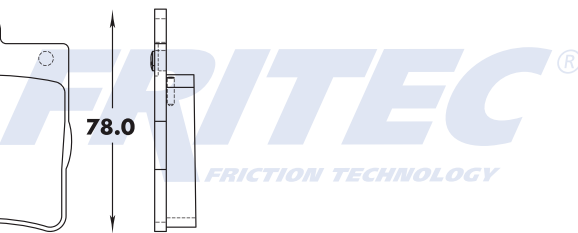
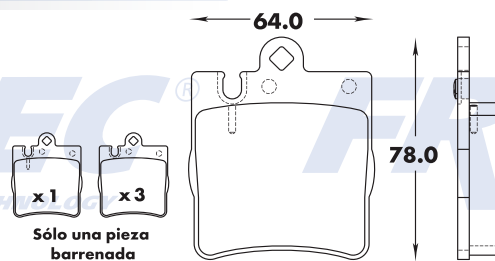

343

8334-Z D1214

D/F	T/R	E/T
X		15.0

8334-Z D1214

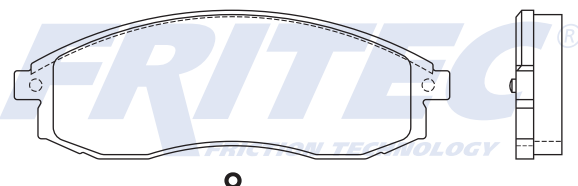
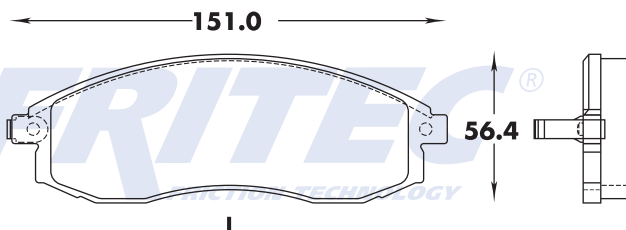

344

7752-Z D1096

D/F	T/R	E/T
X		19.8

7752-Z D1096

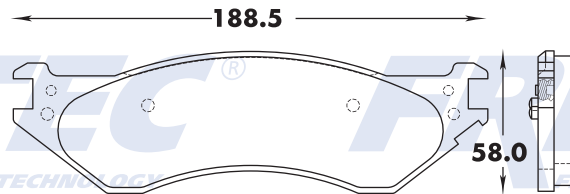

345

7754-Z D877

D/F	T/R	E/T
X		15.2

7754-Z D877

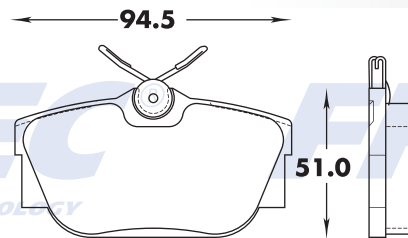

346

7755-AZ D877

D/F	T/R	E/T
X		15.2

7755-AZ D877

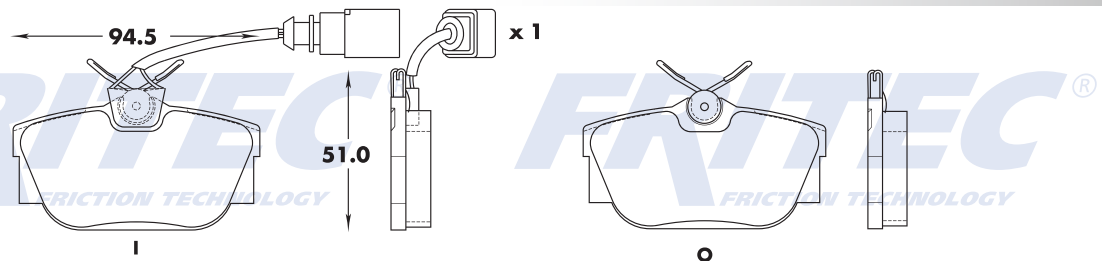

347

7755-BZ D877

D/F	T/R	E/T
X		15.2

7755-BZ D877

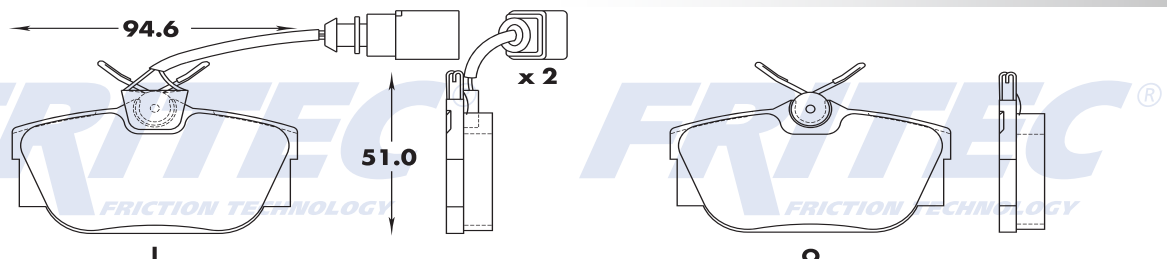

348

7757-Z D880

D/F	T/R	E/T
X		18.7

7757-Z D880

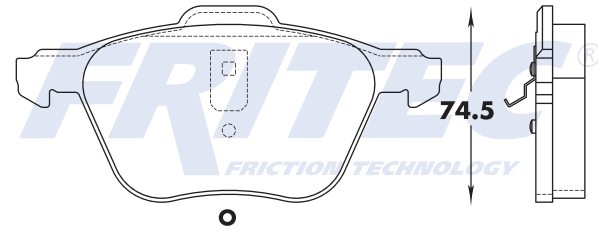
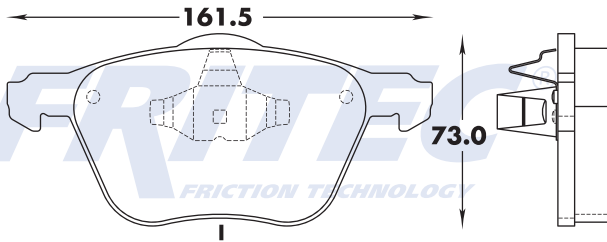

349

7757-AZ D880

D/F	T/R	E/T
X		18.7

7757-AZ D880

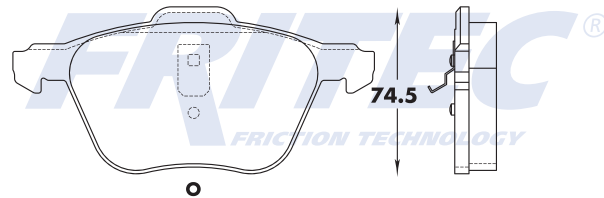
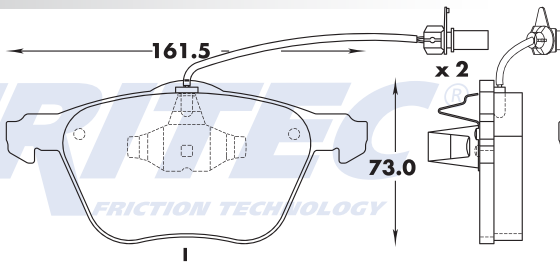

350

7758-Z D881

D/F	T/R	E/T
X		14.6

7758-Z D881

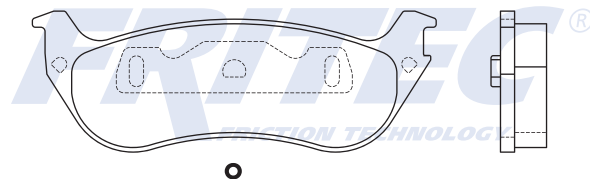
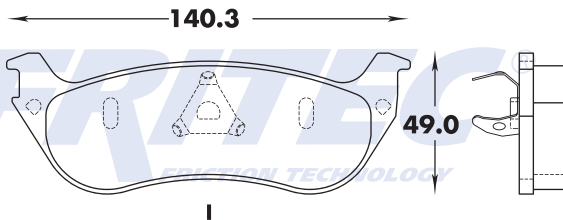

351

7759-Z D882

D/F	T/R	E/T
X		16.7

7759-Z D882

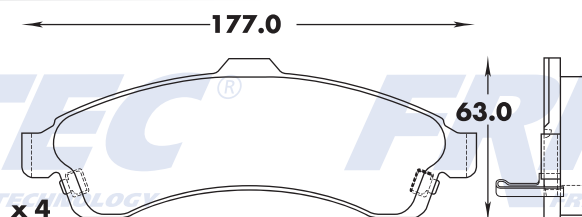

352

9304-Z D2005

D/F	T/R	E/T
X		15.0

9304-Z D2005

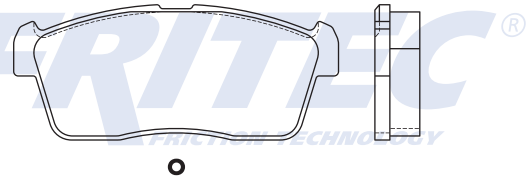
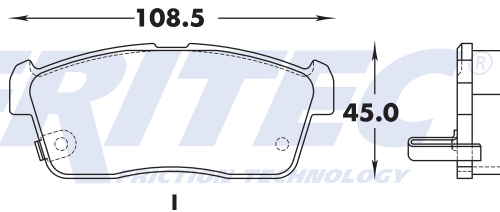

353

7760-Z D883

D/F	T/R	E/T
X		17.4

7760-Z D883

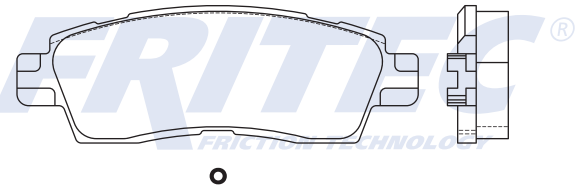
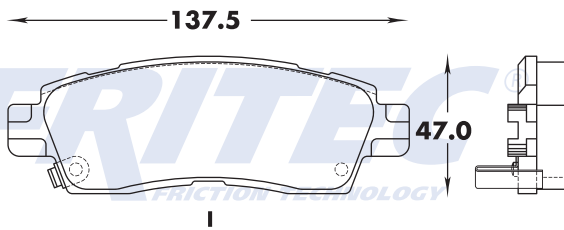

354

7763-Z D886

D/F	T/R	E/T
X		13.8

7763-Z D886

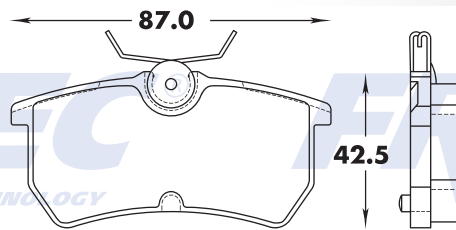

355

8310-Z D1191

D/F	T/R	E/T
X		16.9

8310-Z D1191

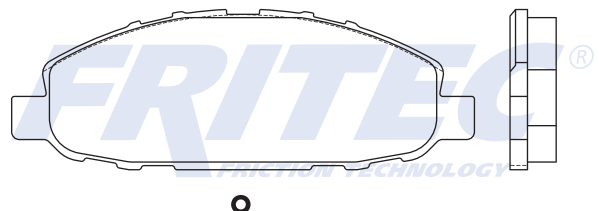
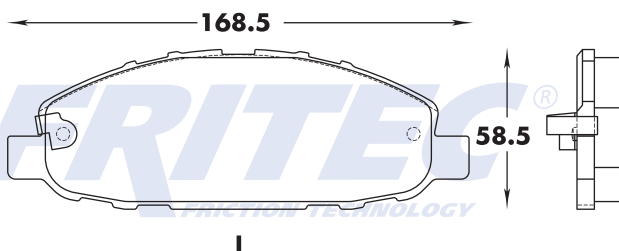

356

7774-Z D897

D/F	T/R	E/T
X		17.7

7774-Z D897

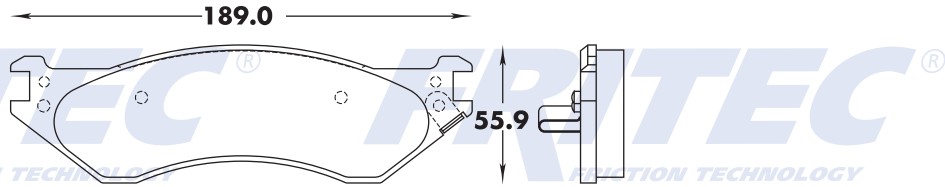

357

7775-Z D898

D/F	T/R	E/T
X		15.9

7775-Z D898

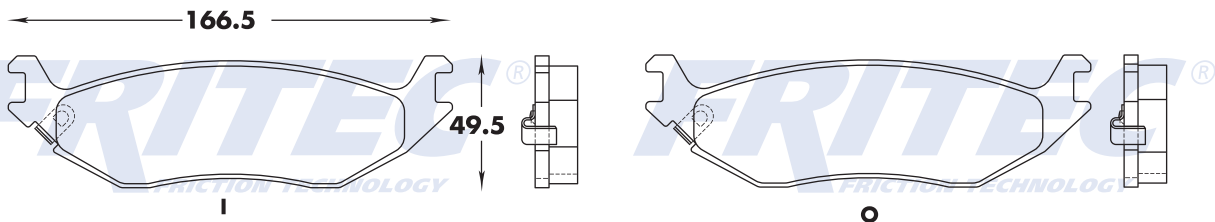

358

7777-Z D900

D/F	T/R	E/T
X		15.9

7777-Z D900

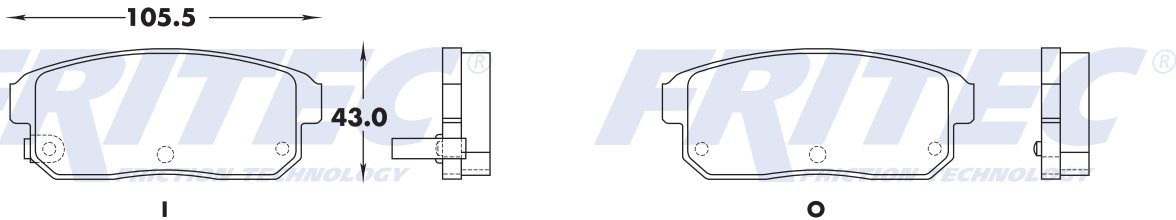

359

7779-Z1 D1035

D/F	T/R	E/T
X		16.9

7779-Z1 D1035

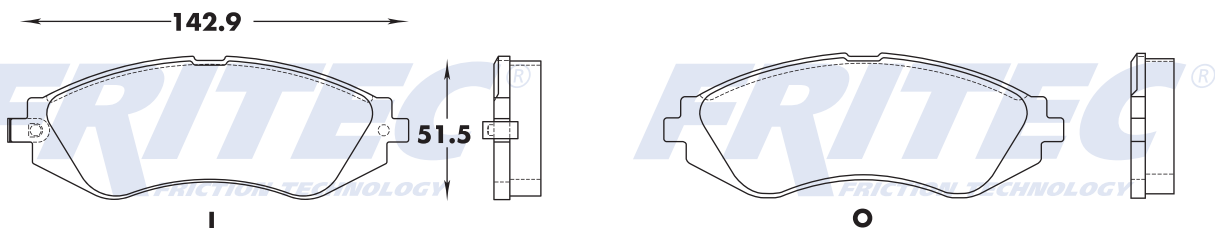

360

777X-Z F199

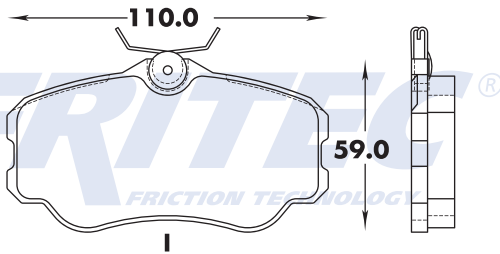

D/F	T/R	E/T
X		14.7

777X-Z F199

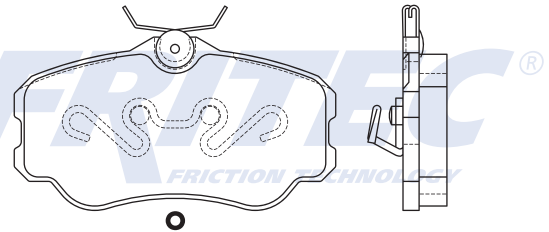

361

7782-Z D904

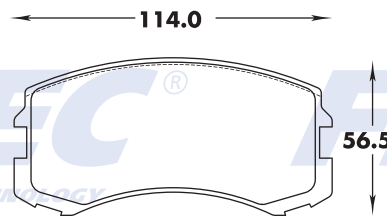

D/F	T/R	E/T
X		15.4

7782-Z D904

362

7783-Z D815

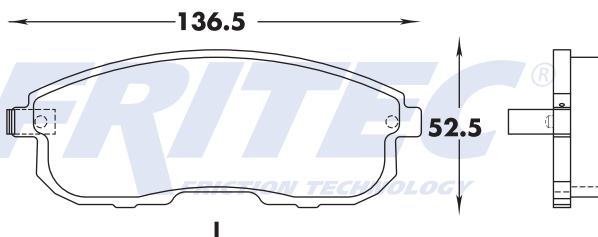

D/F	T/R	E/T
X		15.4

7783-Z D815

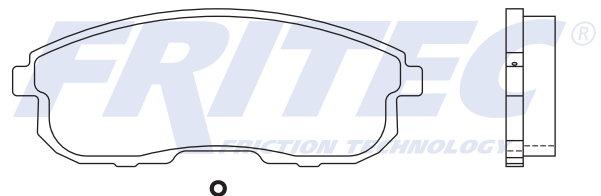

363

7783-AZ D815

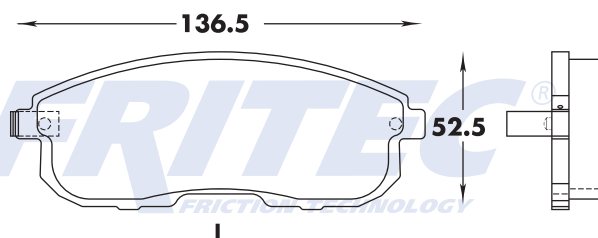

D/F	T/R	E/T
X		15.4, 15.4

7783-AZ D815

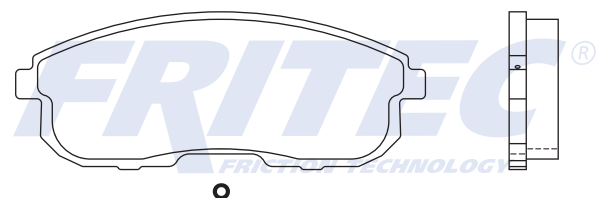

364

7784-Z D905

D/F	T/R	E/T
X		14.2

7784-Z D905

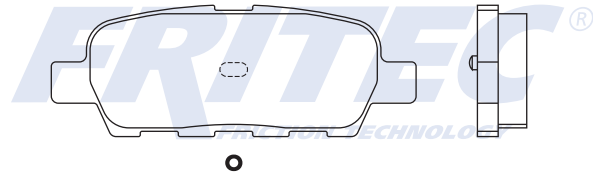
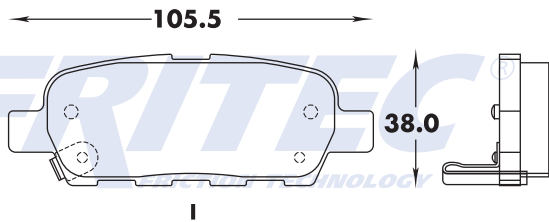

365

7787-Z D908

D/F	T/R	E/T
X		17.3

7787-Z D908

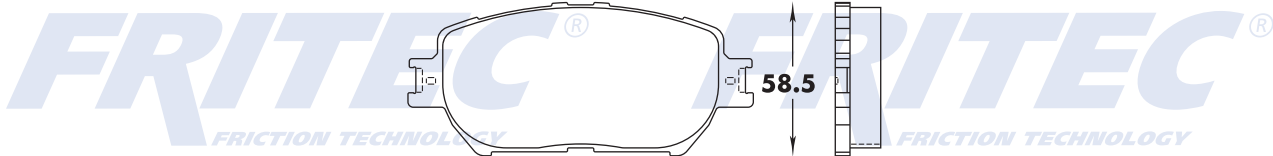
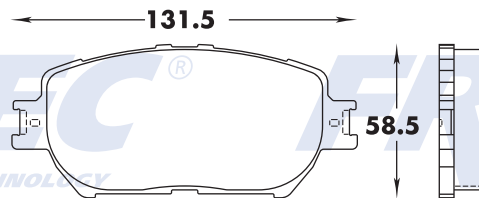

366

7788-Z D909

D/F	T/R	E/T
X		18.9

7788-Z D909

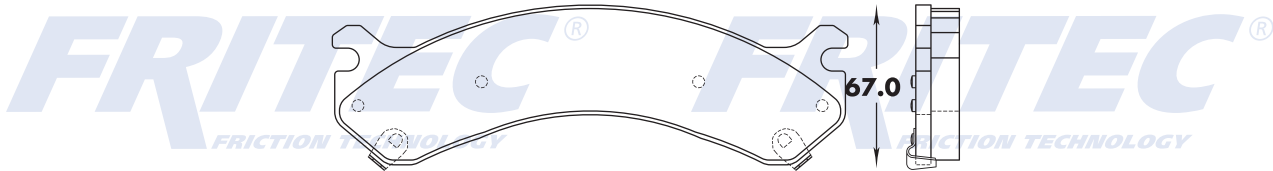
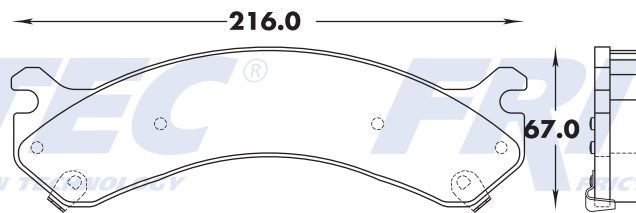

367

7789-Z D910

D/F	T/R	E/T
X		17.4

7789-Z D910

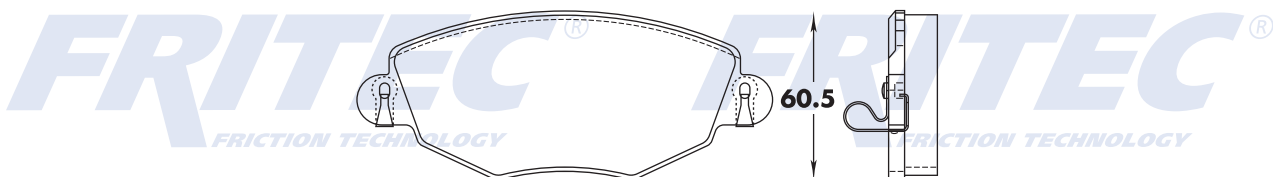
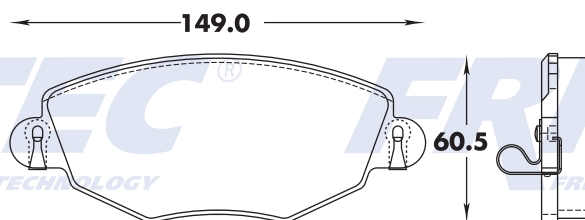

368

778X-Z F202

D/F	T/R	E/T
X		15.7

778X-Z F202

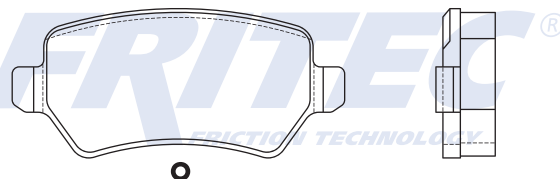
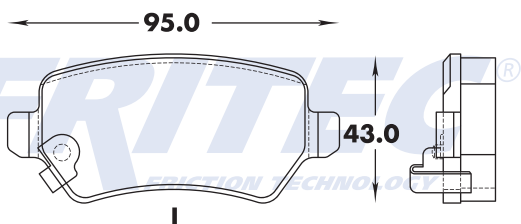

369

7790-Z D911

D/F	T/R	E/T
X		15.9

7790-Z D911

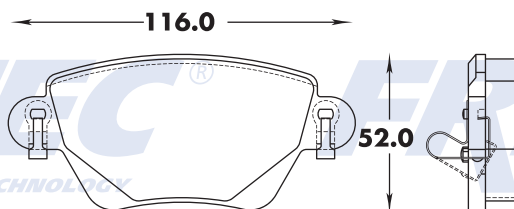

370

7794-Z1 D913

D/F	T/R	E/T
X		16.1

7794-Z1 D913

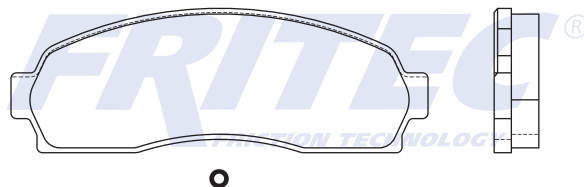
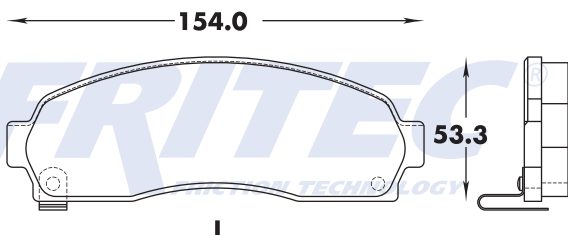

371

7795-Z D914

D/F	T/R	E/T
X		16.9

7795-Z D914

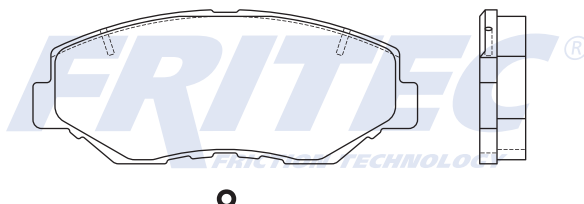
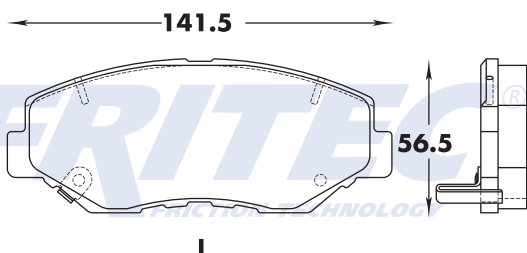

372

7796-Z1 D1111

D/F	T/R	E/T
X		19.3

7796-Z1 D1111

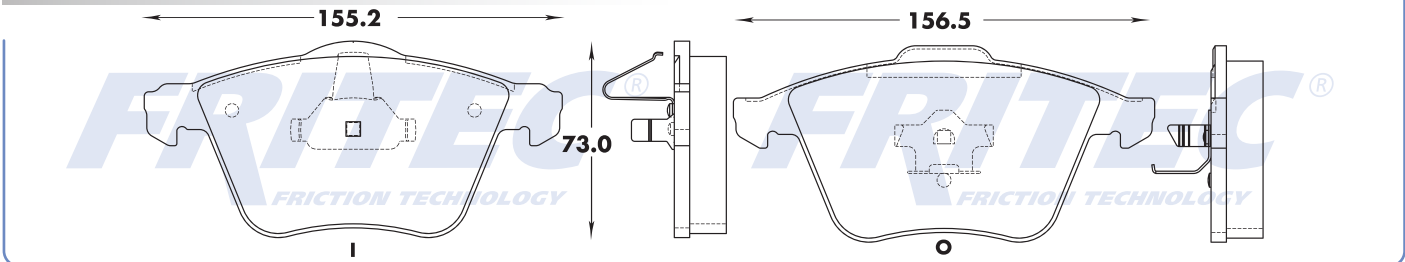

373

7799-Z D918

D/F	T/R	E/T
X		19.0

7799-Z D918

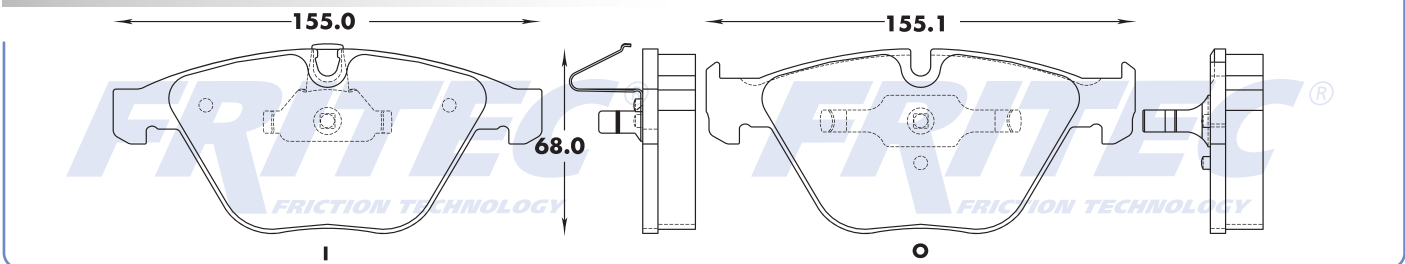

374

7799-Z1 D1260

D/F	T/R	E/T
X		19.0

7799-Z1 D1260

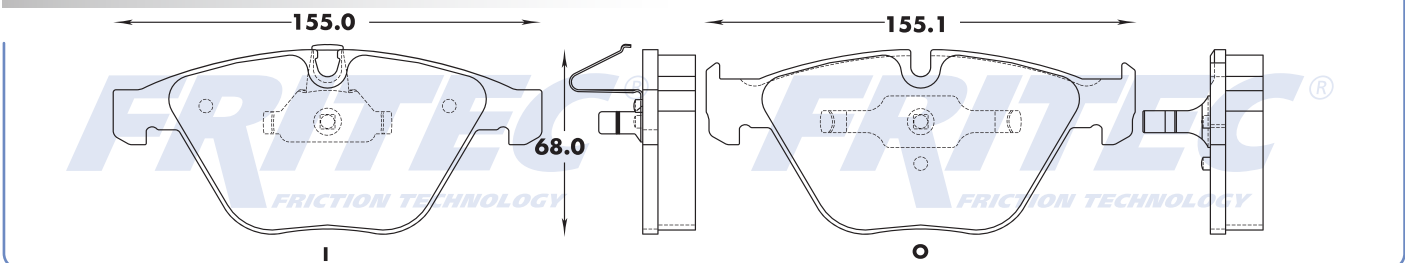

375

779X-Z D350

D/F	T/R	E/T
X		15.1

779X-Z D350

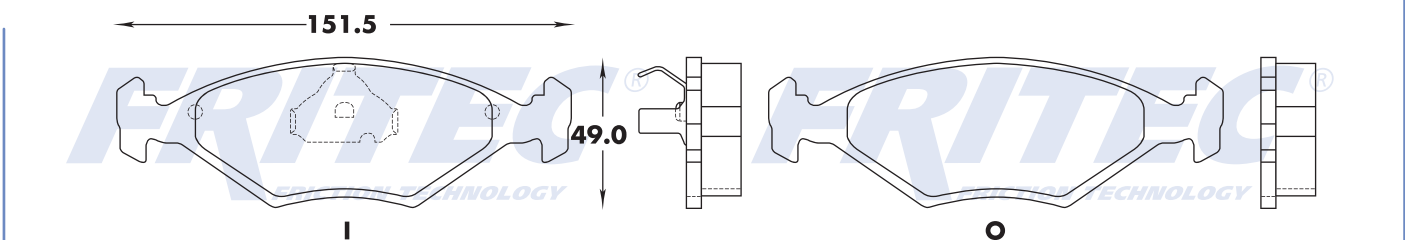

376

77W3-Z D1911

D/F	T/R	E/T
X		16.9

77W3-Z D1911

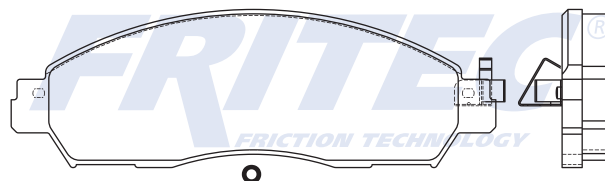
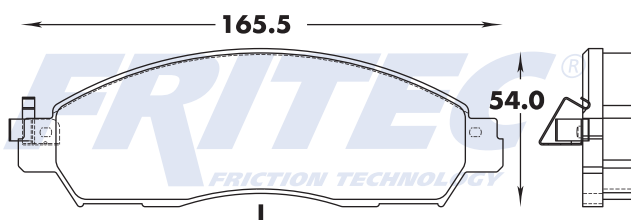

377

8288-Z D350

D/F	T/R	E/T
X		15.1

8288-Z D350

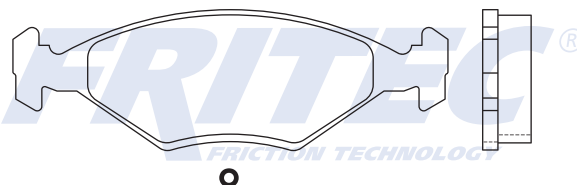
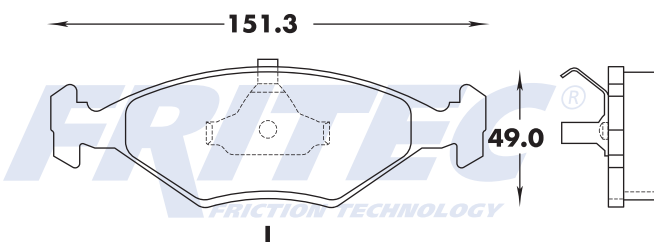

378

7815-Z D380

D/F	T/R	E/T
X		21.8, 16.6

7815-Z D380

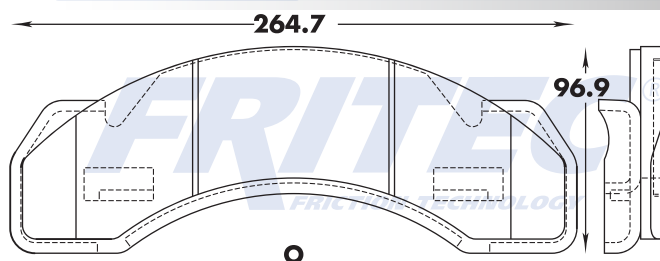
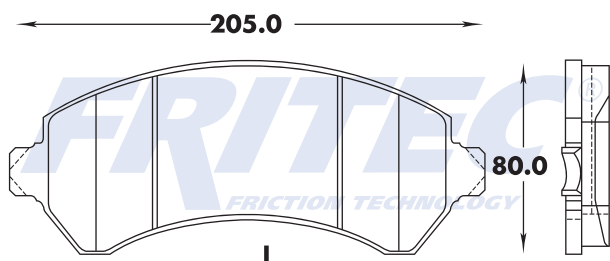

379

7820-Z D919

D/F	T/R	E/T
X		15.9

7820-Z D919

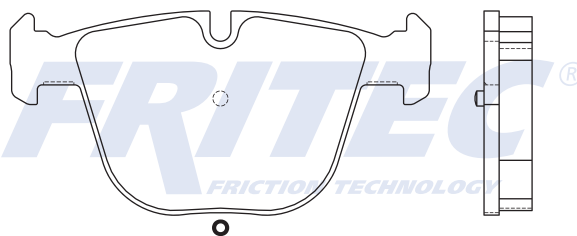
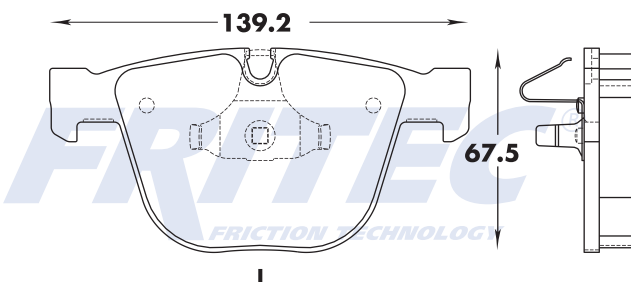

380

7824-Z D923

D/F	T/R	E/T
X		16.8

7824-Z D923

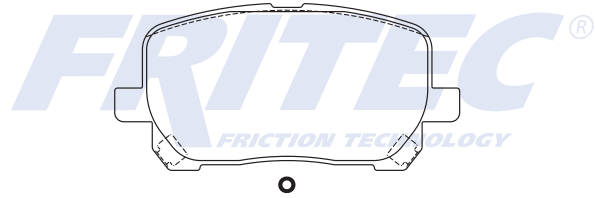
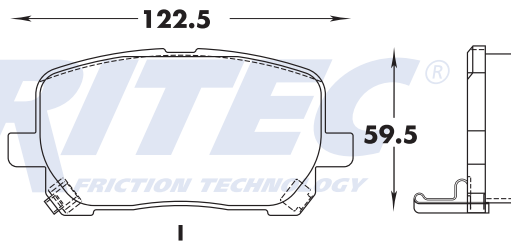

381

7825-Z D924

D/F	T/R	E/T
X		16.9

7825-Z D924

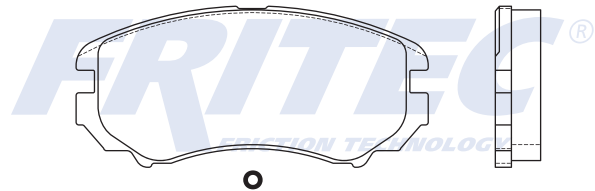
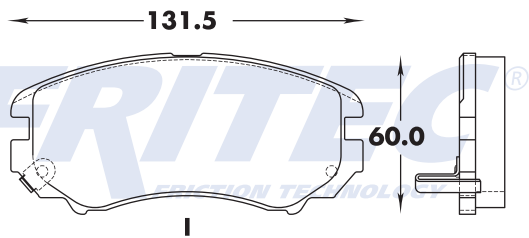

382

7827-Z D926

D/F	T/R	E/T
X		17.2

7827-Z D926

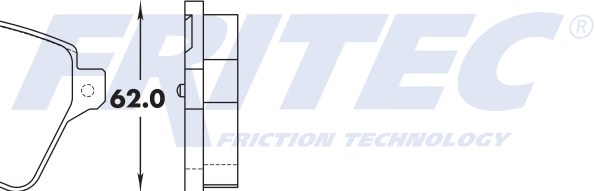
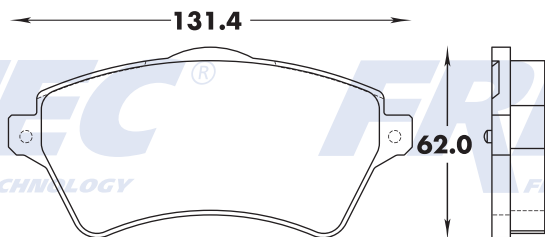

383

782Y-Z F369

D/F	T/R	E/T
X		16.4

782Y-Z F369

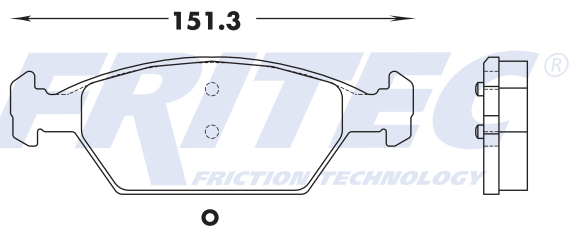
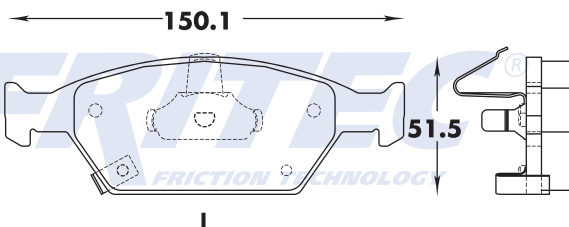

384

7832-Z D815

D/F	T/R	E/T
X		16.4

7832-Z D815

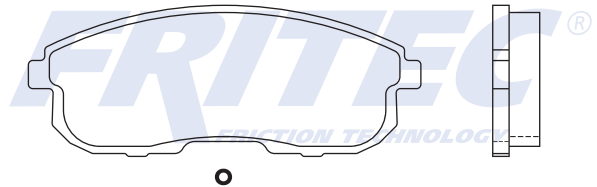
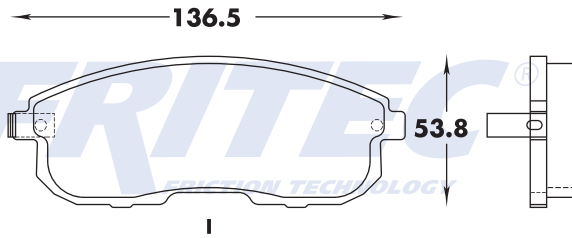

385

7834-Z D931

D/F	T/R	E/T
X		16.6

7834-Z D931

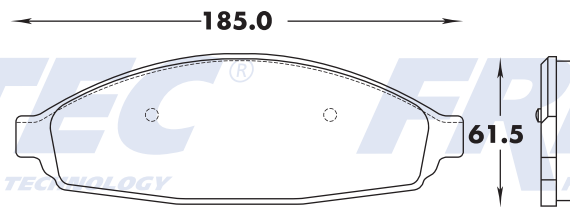

386

7835-Z D932

D/F	T/R	E/T
X		15.6

7835-Z D932

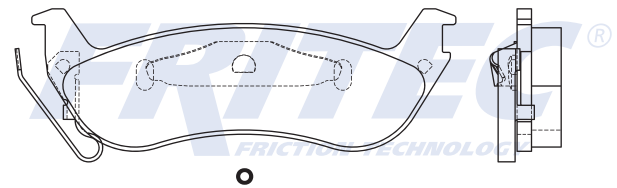
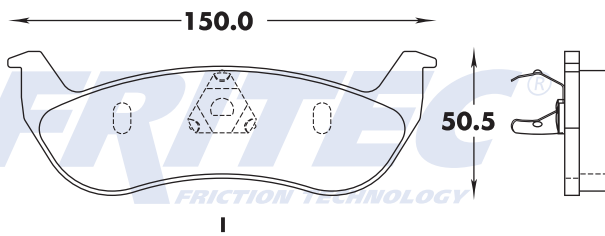

387

7837-Z D934

D/F	T/R	E/T
X		21.0

7837-Z D934

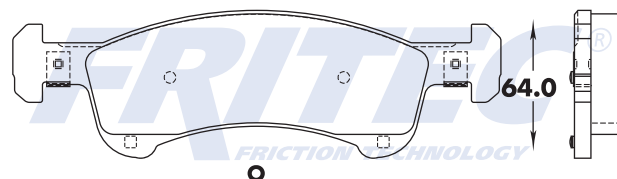
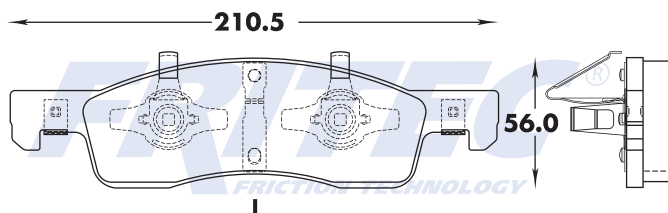

388

7838-Z D935

D/F	T/R	E/T
X		20.0

7838-Z D935

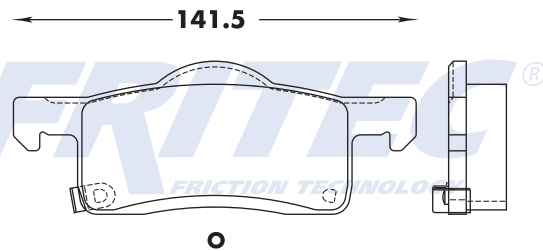
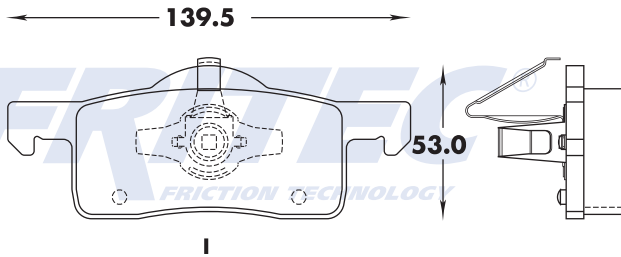

389

7841-Z D939

D/F	T/R	E/T
X		17.4

7841-Z D939

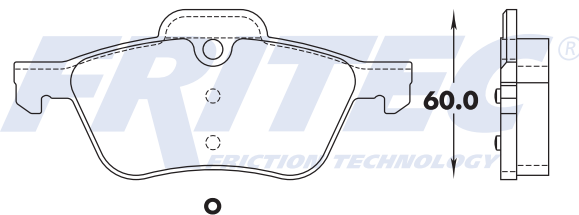
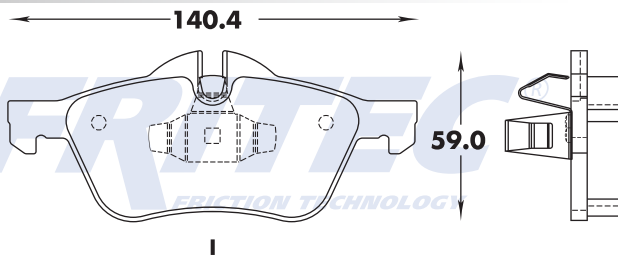

390

7842-Z1 D1060

D/F	T/R	E/T
X		15.5

7842-Z1 D1060

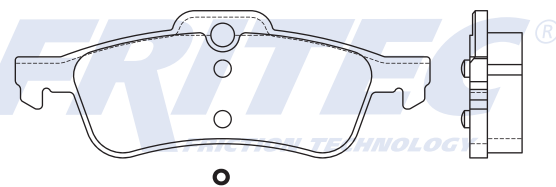
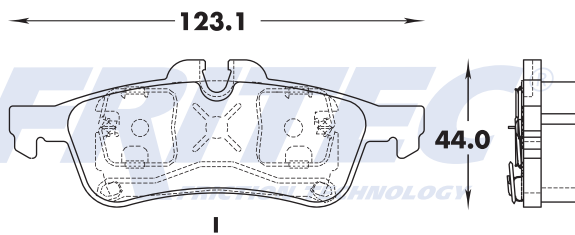

391

7846-Z D945

D/F	T/R	E/T
X		18.4

7846-Z D945

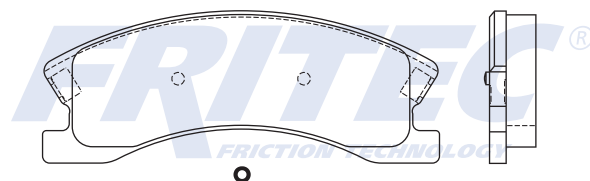
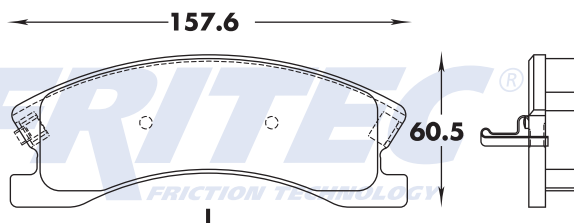

392

7847-Z D781

D/F	T/R	E/T
X		16.6, 16.8

7847-Z D781

150.0

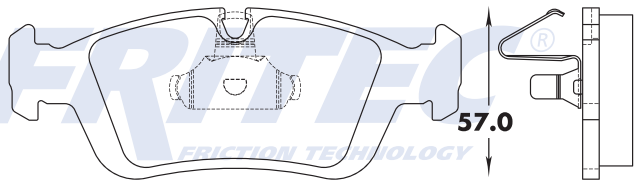

I

151.3

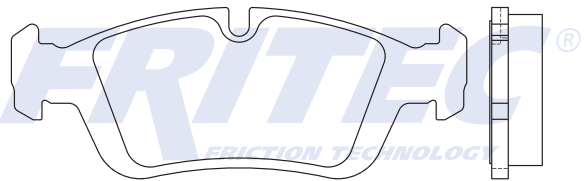

O

393

7848-Z D949

D/F	T/R	E/T
X		19.1

7848-Z D949

164.4

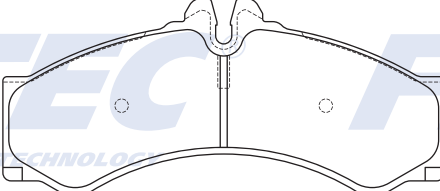

73.0

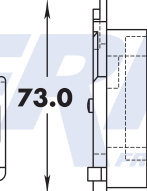

394

7848A-Z D949

D/F	T/R	E/T
X		19.1

7848A-Z D949

164.4

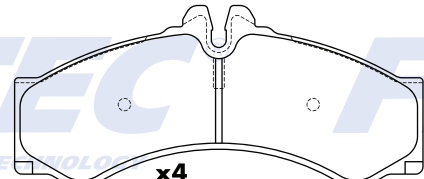

73.0

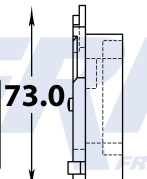

x4

395

7849-Z D950

D/F	T/R	E/T
X		19.3

7849-Z D950

156.5

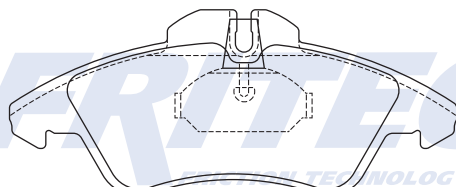

65.0

I

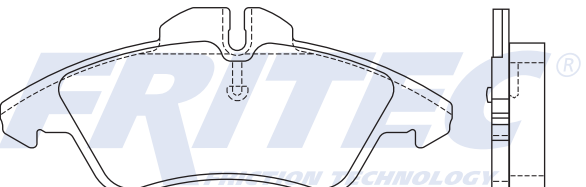

O

396

7852-Z D953

D/F	T/R	E/T
X		16.3

7852-Z D953

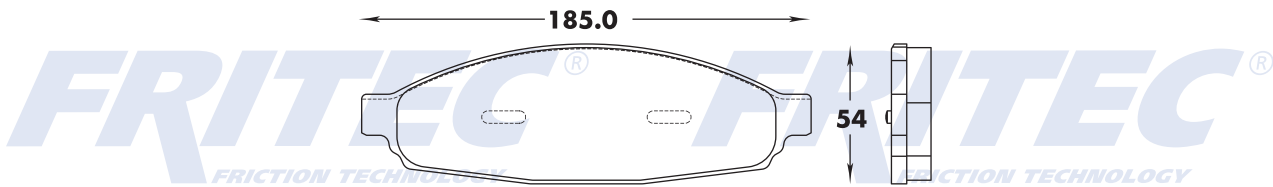

397

7855-Z D956

D/F	T/R	E/T
X		17.5

7855-Z D956

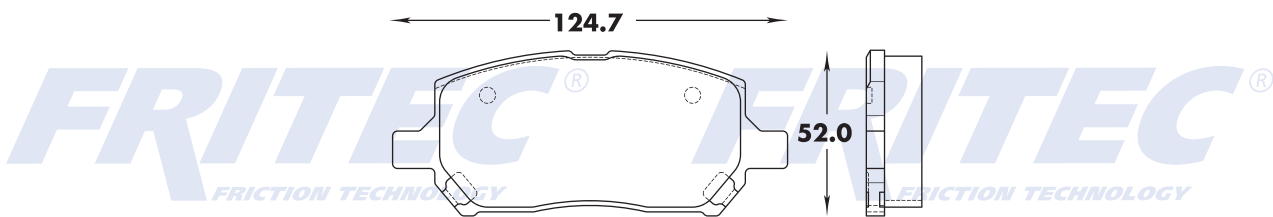

398

7856-Z D957

D/F	T/R	E/T
X		17.8

7856-Z D957

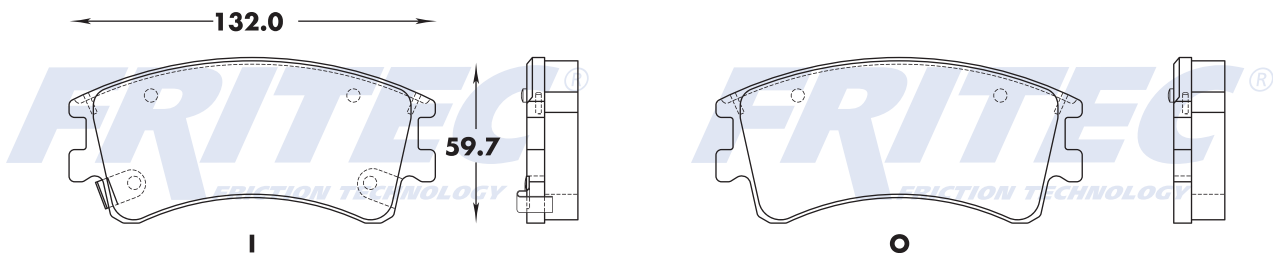

399

7861-Z D962

D/F	T/R	E/T
X		17.9

7861-Z D962

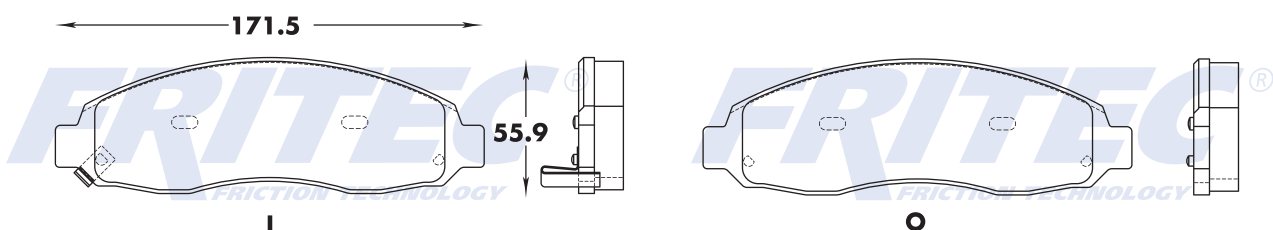

400

7863-Z D964

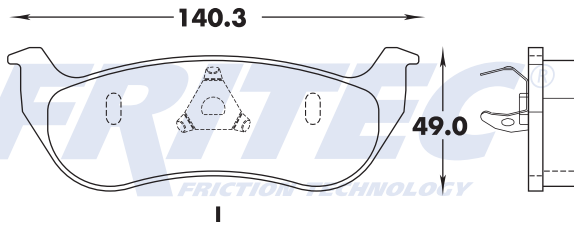

D/F	T/R	E/T
X		14.0

7863-Z D964

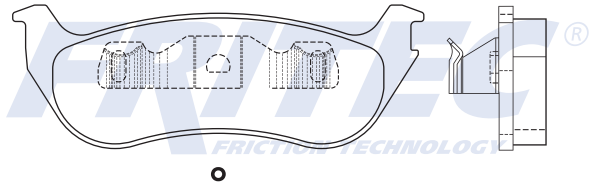

401

7863-Z1 D981

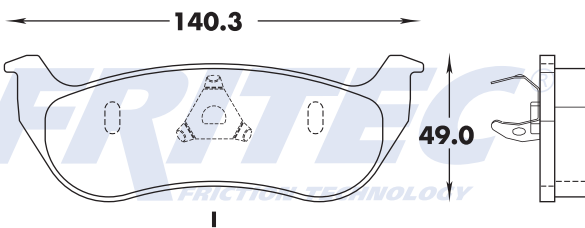

D/F	T/R	E/T
X		14.0

7863-Z1 D981

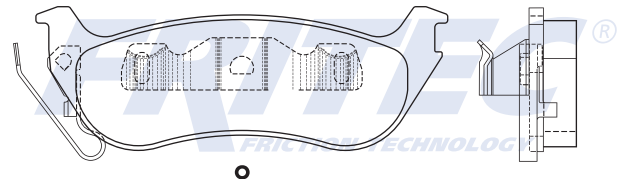

402

7864-Z D965

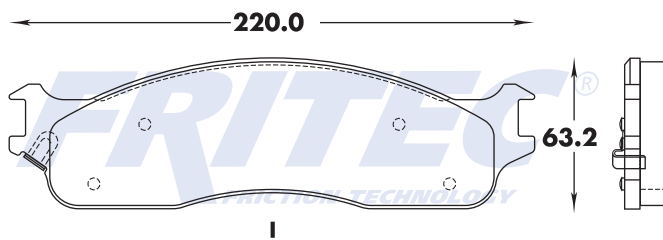

D/F	T/R	E/T
X		18.3

7864-Z D965

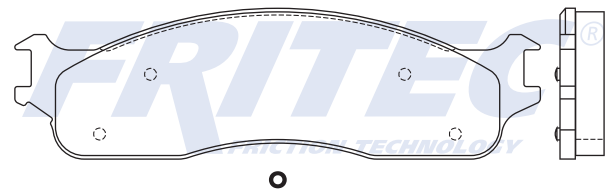

403

7865-Z D1077

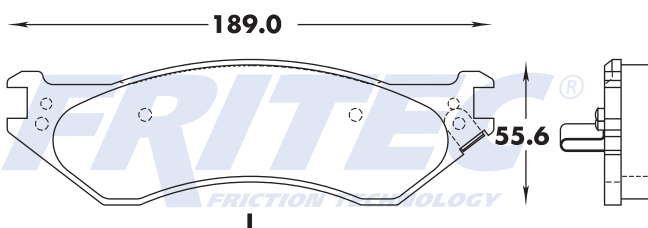

D/F	T/R	E/T
X		19.8

7865-Z D1077

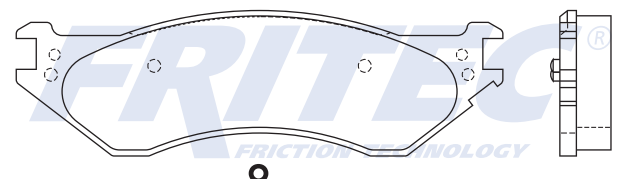

404

7866-Z D966

D/F	T/R	E/T
X		16.5

7866-Z D966

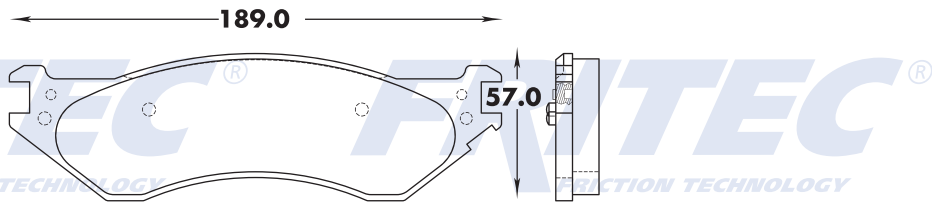

405

7869-Z D967

D/F	T/R	E/T
X		15.5

7869-Z D967

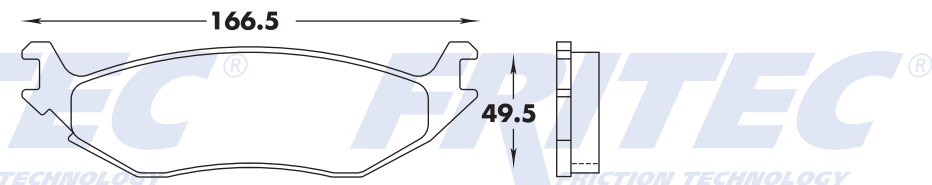

406

7870-Z D969

D/F	T/R	E/T
X		15.5

7870-Z D969

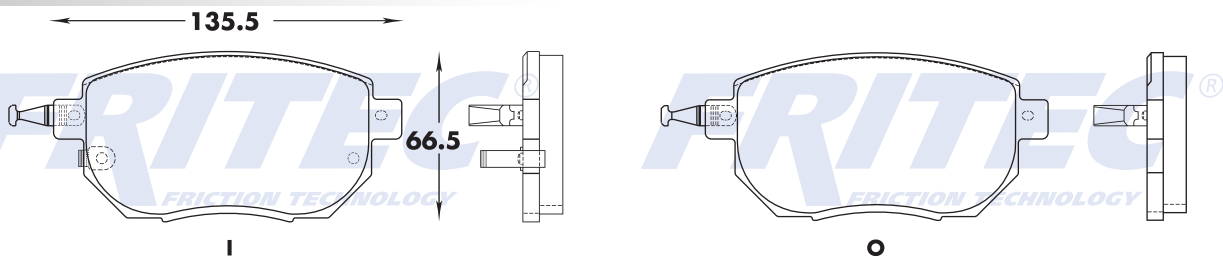

407

7871-Z D970

D/F	T/R	E/T
X		17.2, 16.8

7871-Z D970

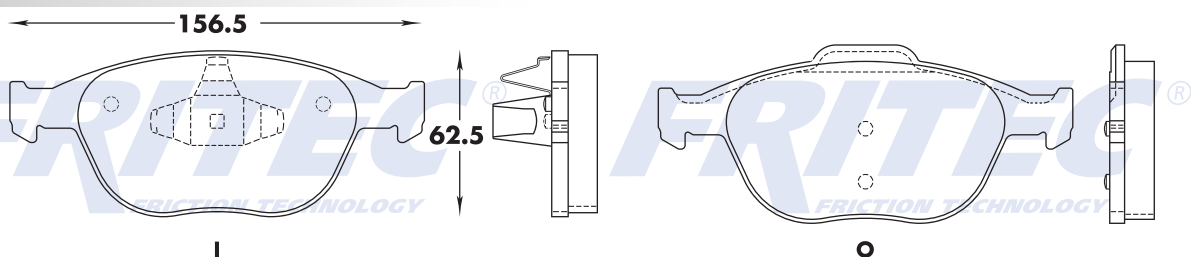

408

7873-Z D972

D/F	T/R	E/T
X		19.4

7873-Z D972

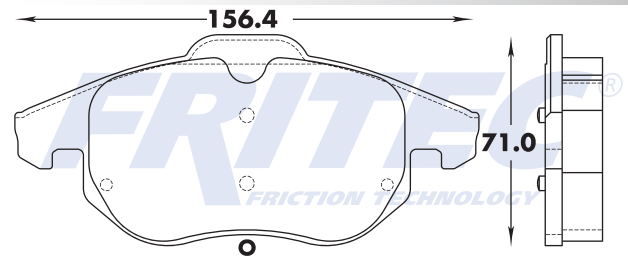
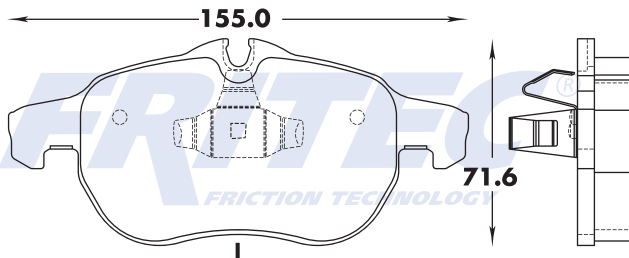

409

7874-Z D973

D/F	T/R	E/T
X		15.4

7874-Z D973

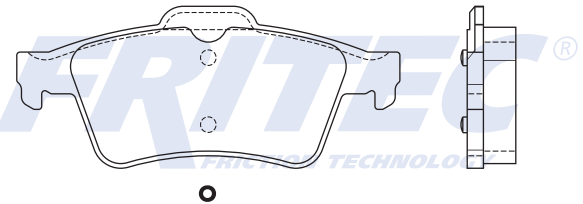
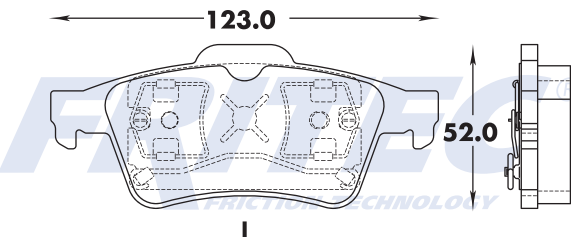

410

7875-Z D974

D/F	T/R	E/T
X		20.1

7875-Z D974

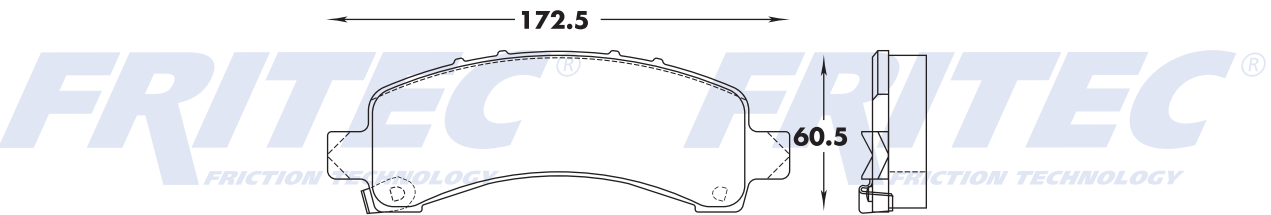

411

7876-Z D830

D/F	T/R	E/T
X		16.0

7876-Z D830

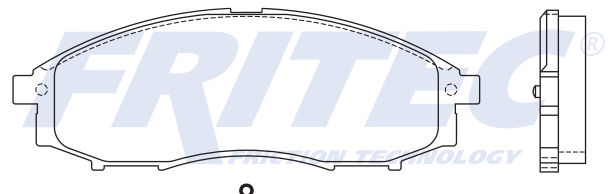
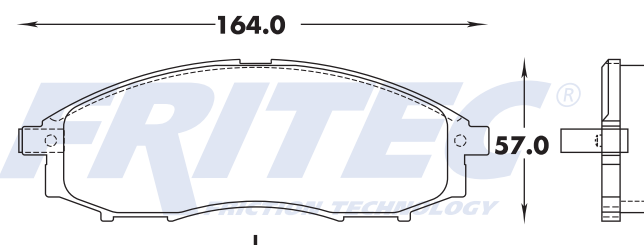

412

7877-Z D976

D/F	T/R	E/T
X		17.0

7877-Z D976

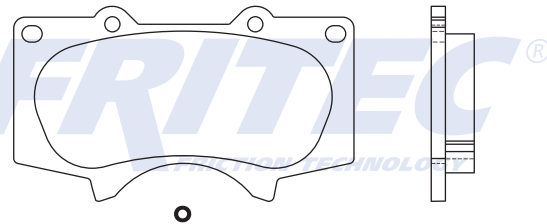
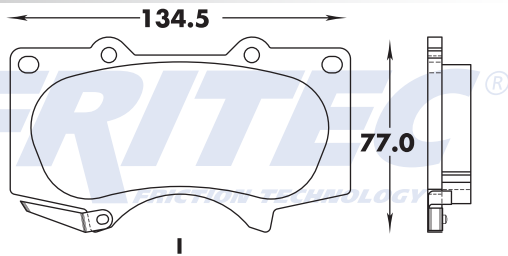

413

7878-Z D1014

D/F	T/R	E/T
X		15.8

7878-Z D1014

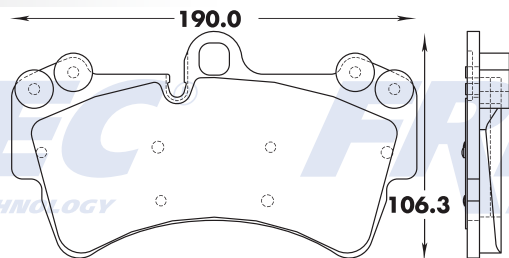

414

7880-Z D929

D/F	T/R	E/T
X		16.8

7880-Z D929

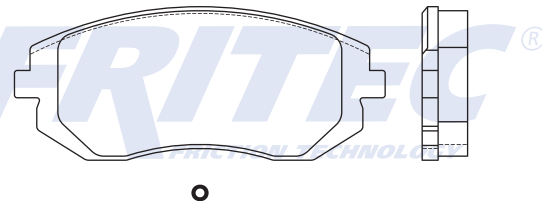
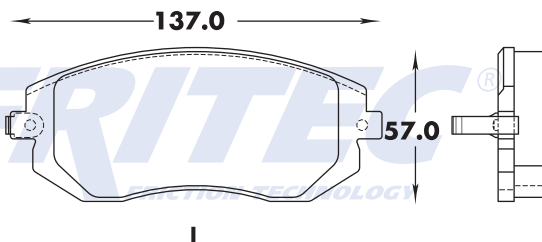

415

7881-Z D974

D/F	T/R	E/T
X		17.0

7881-Z D974

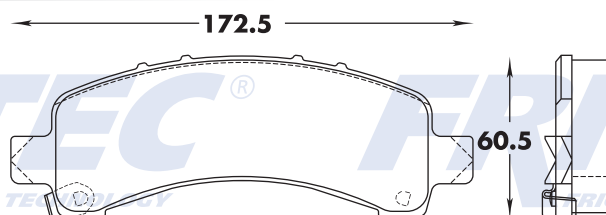

416

7888-Z D986

D/F	T/R	E/T
X		15.8

7888-Z D986

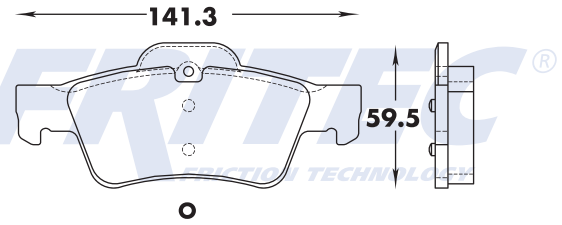
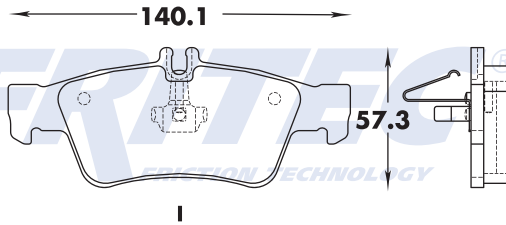

417

7891-Z D989

D/F	T/R	E/T
X		19.4

7891-Z D989

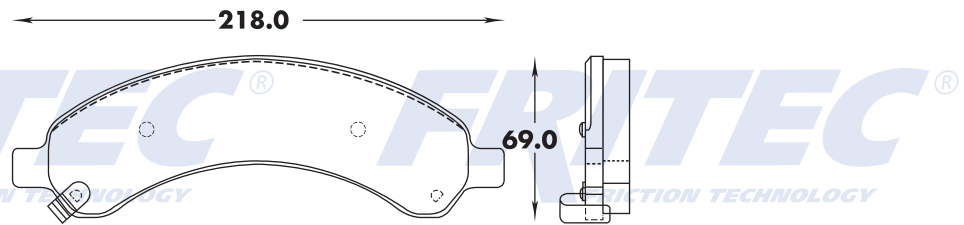

418

7895-Z D995

D/F	T/R	E/T
X		16.6

7895-Z D995

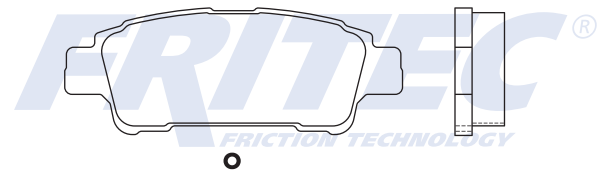
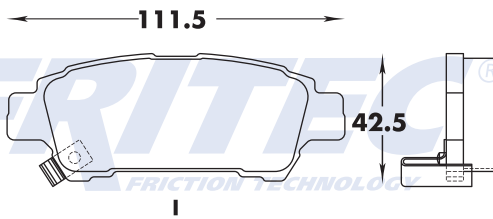

419

7896-Z D906

D/F	T/R	E/T
X		17.4

7896-Z D906

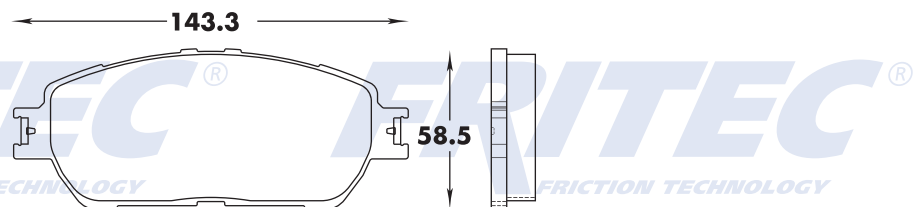

420

7898-Z D997

D/F	T/R	E/T
X		16.5

7898-Z D997

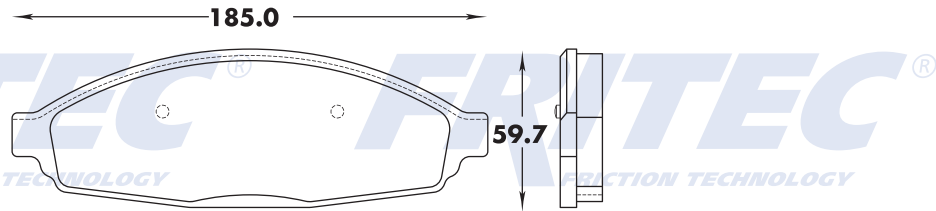

421

7899-Z D998

D/F	T/R	E/T
X		18.0

7899-Z D998

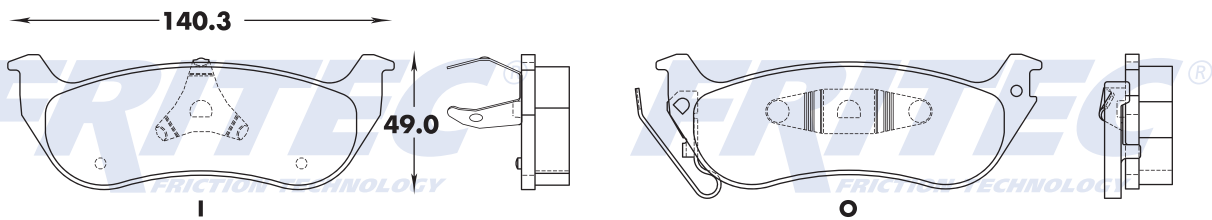

422

8246-Z D1136

D/F	T/R	E/T
X		19.1

8246-Z D1136

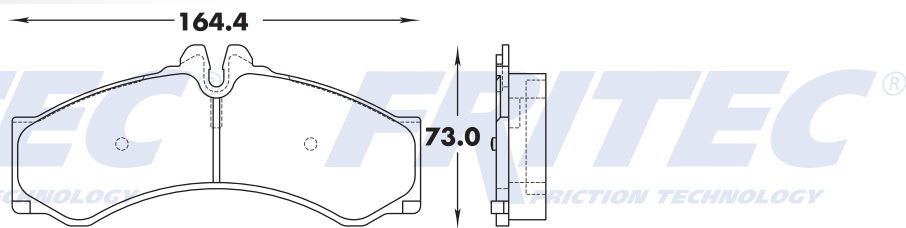

423

8934-Z D1710

D/F	T/R	E/T
X		16.0

8934-Z D1710

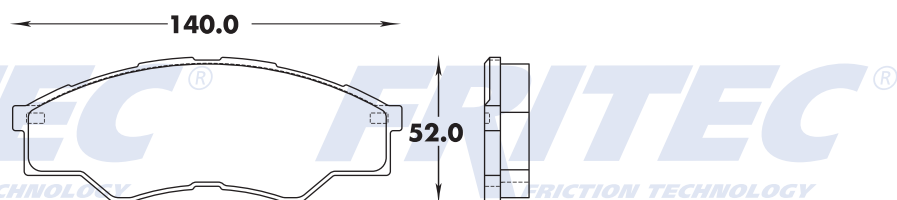

424

8924-Z D1700

D/F	T/R	E/T
X		20.8

8924-Z D1700

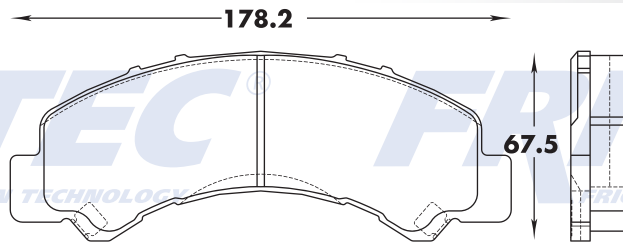

425

9195-Z D1970

D/F	T/R	E/T
X		18.3

9195-Z D1970

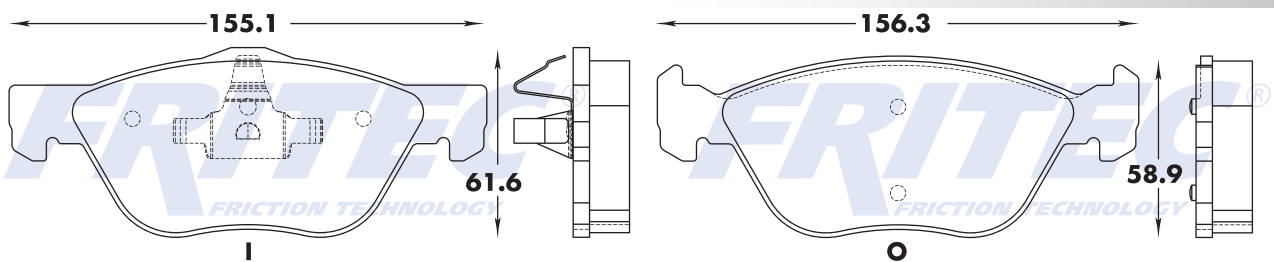

426

7902-Z D1001

D/F	T/R	E/T
X		14.8

7902-Z D1001

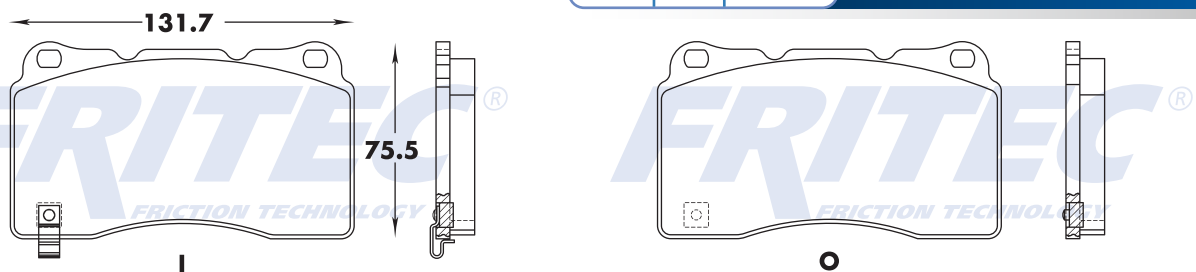

427

7904-Z D1003

D/F	T/R	E/T
X		19.2, 18.2

7904-Z D1003

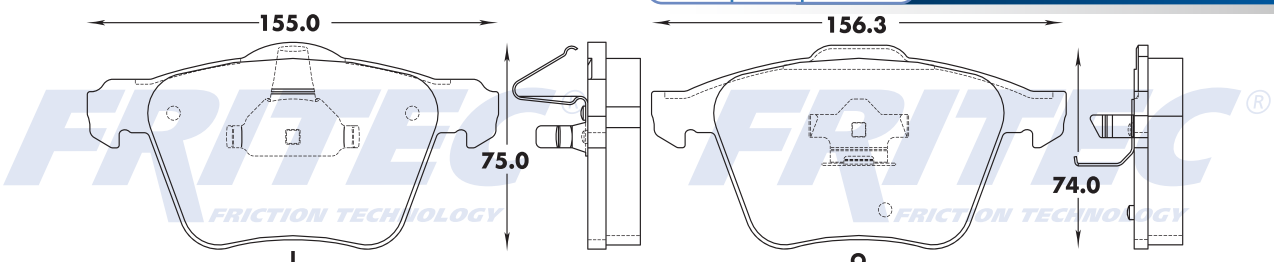

428

7907-Z D881

D/F	T/R	E/T
X		15.2

7907-Z D881

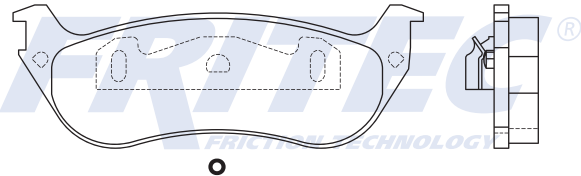
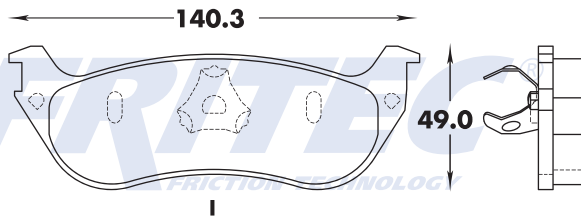

429

7908-AZ D978

D/F	T/R	E/T
X		15.4

7908-AZ D978

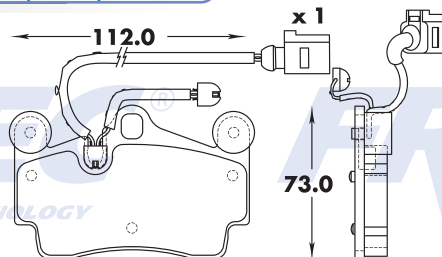

430

7909-Z D1006

D/F	T/R	E/T
X		17.9

7909-Z D1006

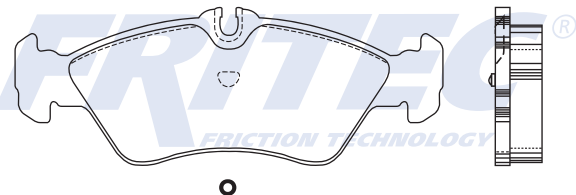
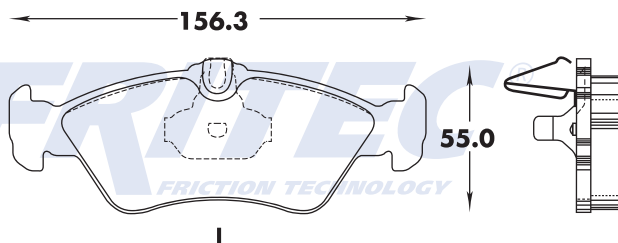

431

7909B-Z D1006B

D/F	T/R	E/T
X		17.9

7909B-Z D1006B

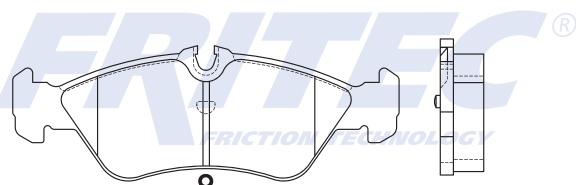
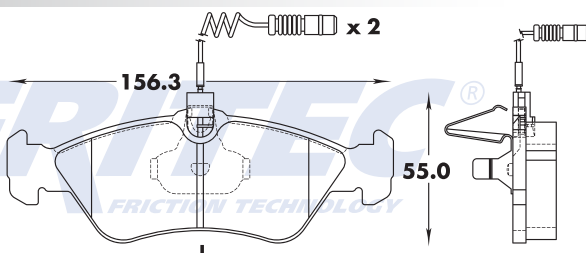

432

7910-Z D855

D/F	T/R	E/T
X		15.4

7910-Z D855

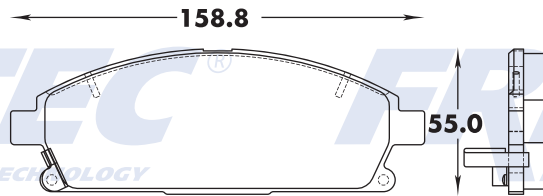

433

7911-Z D1007

D/F	T/R	E/T
X		15.4

7911-Z D1007

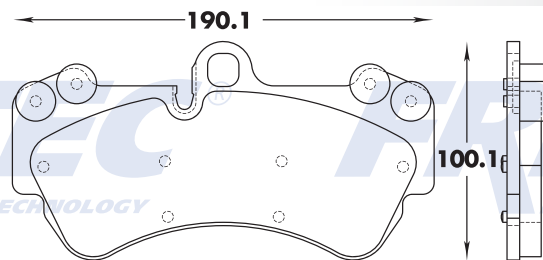

434

7915-Z1 D1083

D/F	T/R	E/T
X		20.0

7915-Z1 D1083

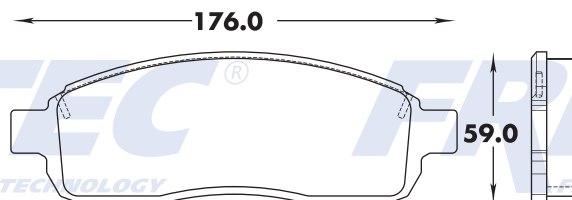

435

7915-Z2 D1392

D/F	T/R	E/T
X		20.0

7915-Z2 D1392

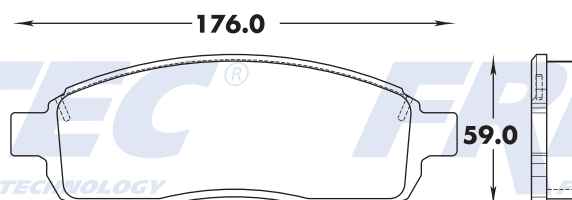

436

7916-Z D1012

D/F	T/R	E/T
X		17.9

7916-Z D1012

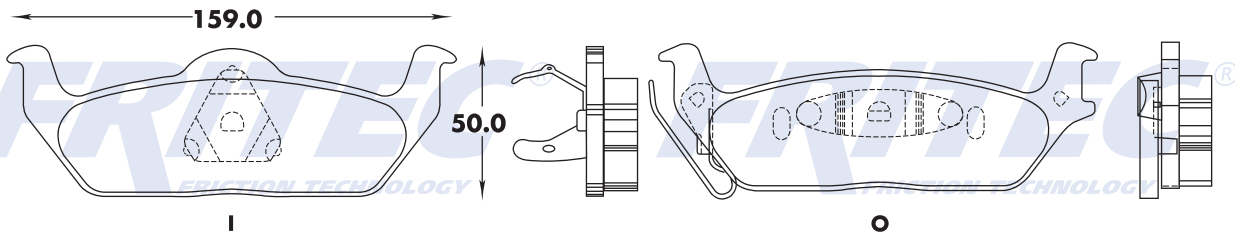

437

7918-Z D1015

D/F	T/R	E/T
X		18.0

7918-Z D1015

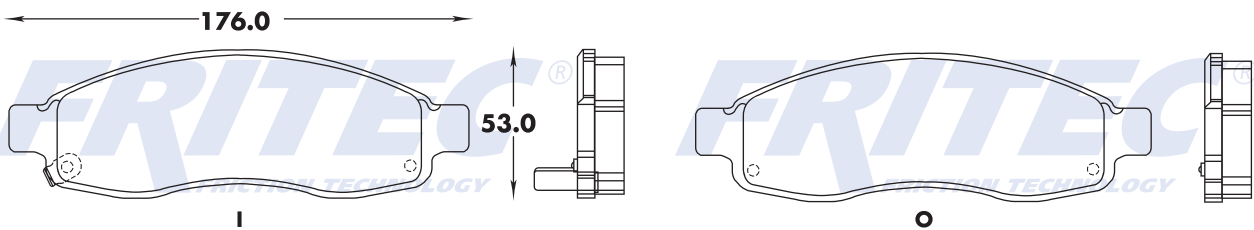

438

7921-Z D1018

D/F	T/R	E/T
X		16.5

7921-Z D1018

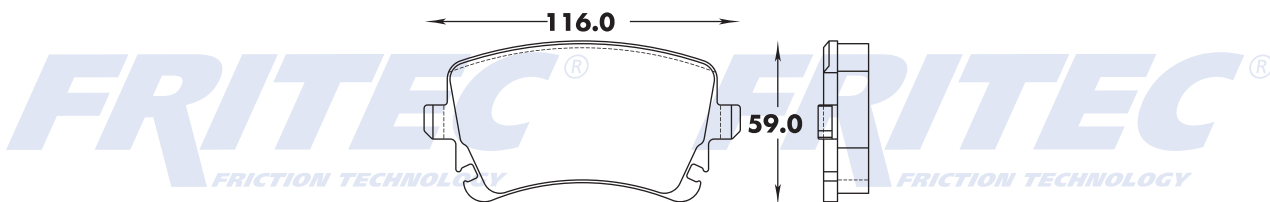

439

7921A-Z D1018

D/F	T/R	E/T
X		16.5

7921A-Z D1018

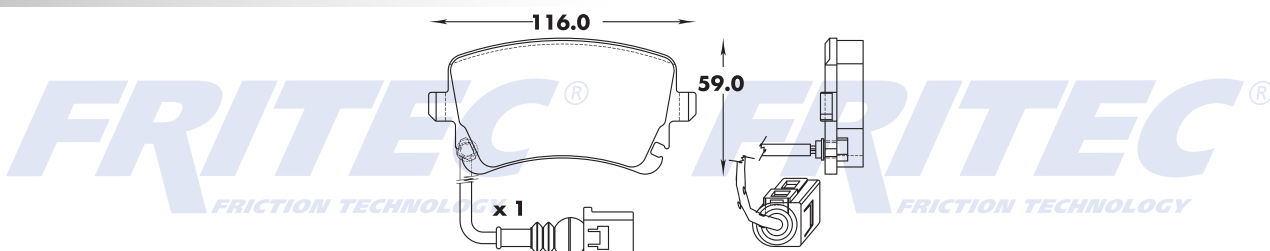

440

7926-Z D1021

D/F	T/R	E/T
X		16.8

7926-Z D1021

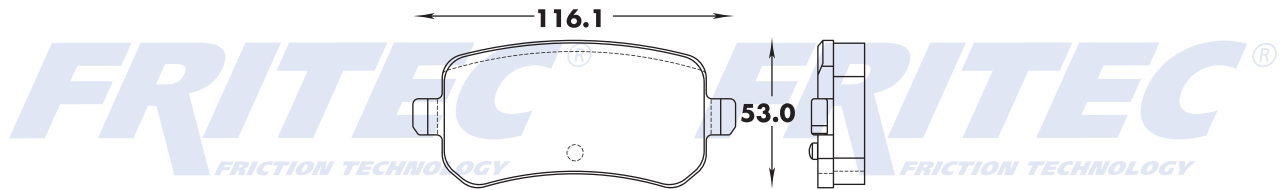

441

7927-Z D1022

D/F	T/R	E/T
X		18.0

7927-Z D1022

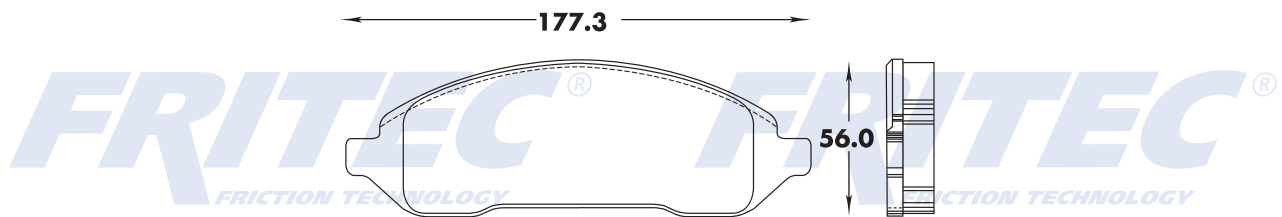

442

7932-Z D1028

D/F	T/R	E/T
X		18.8

7932-Z D1028

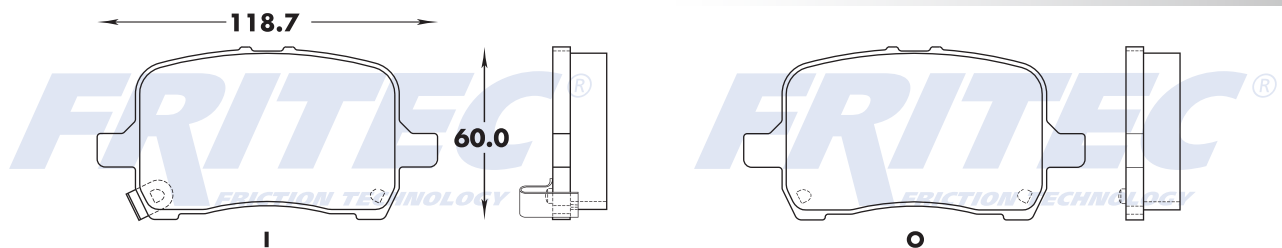

443

7937-Z D1033

D/F	T/R	E/T
X		13.7

7937-Z D1033

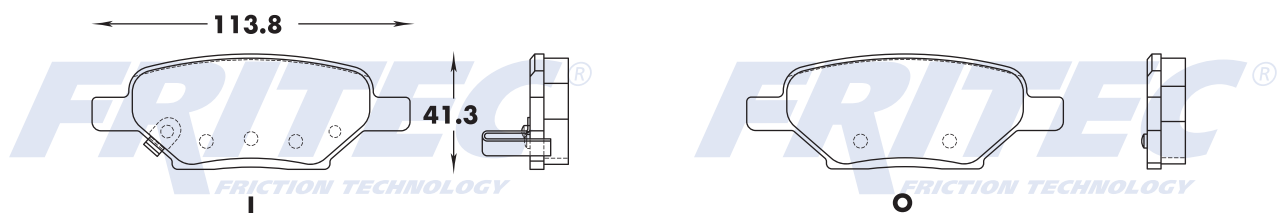

444

7939-Z D1036

D/F	T/R	E/T
X		14.0

7939-Z D1036

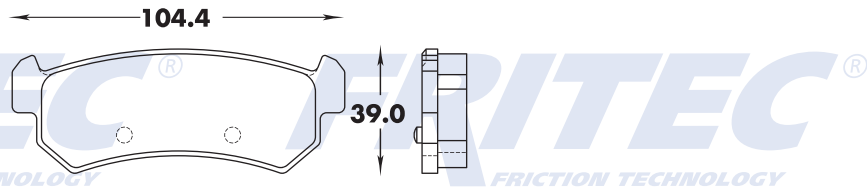

445

7939-Z1 D1315

D/F	T/R	E/T
X		14.0

7939-Z1 D1315

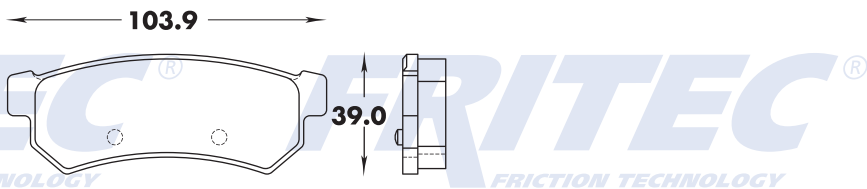

446

7940-Z D1037

D/F	T/R	E/T
X		15.4

7940-Z D1037

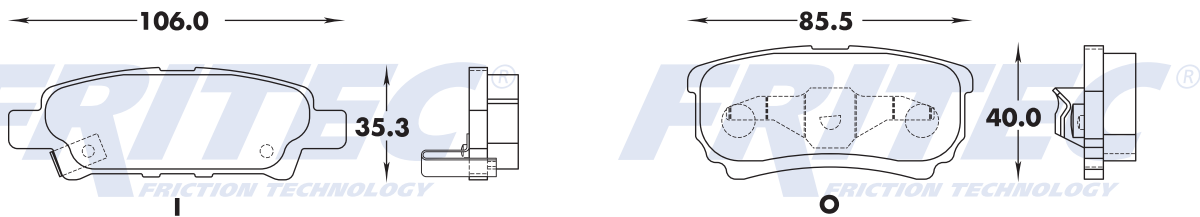

447

7943-Z D1039

D/F	T/R	E/T
X		16.4

7943-Z D1039

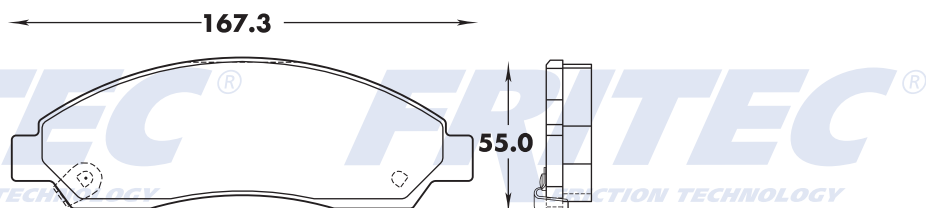

448

7945-Z D1041

D/F	T/R	E/T
X		17.3

7945-Z D1041

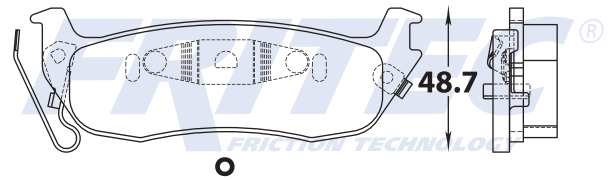
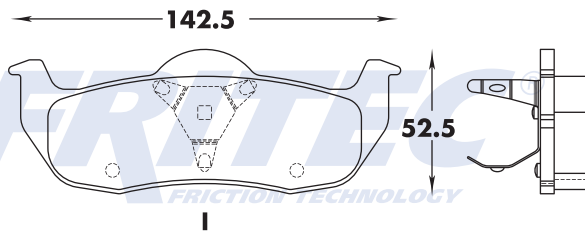

449

7947-Z D1044

D/F	T/R	E/T
X		17.3

7947-Z D1044

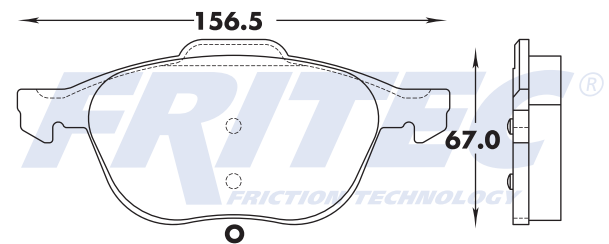
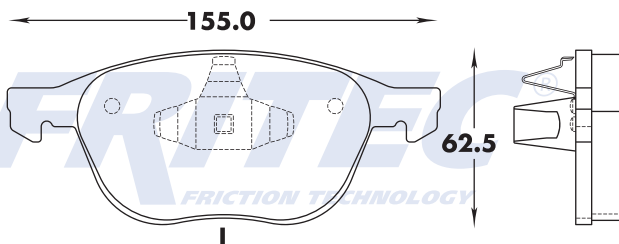

450

7948-Z D1045

D/F	T/R	E/T
X		18.0

7948-Z D1045

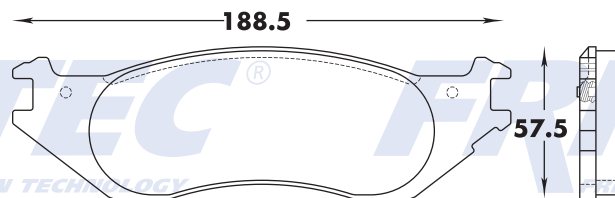

451

7949-Z D1046

D/F	T/R	E/T
X		15.9

7949-Z D1046

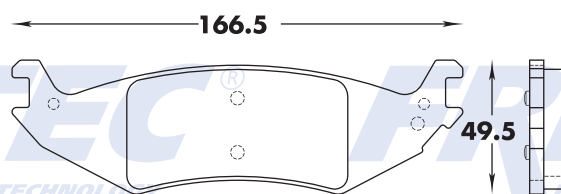

452

7950-Z D1047

D/F	T/R	E/T
X		15.0

7950-Z D1047

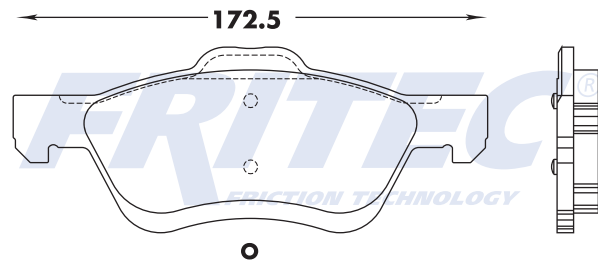
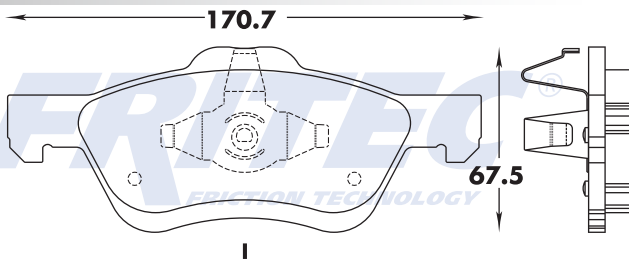

453

7955-Z D1051

D/F	T/R	E/T
X		13.8

7955-Z D1051

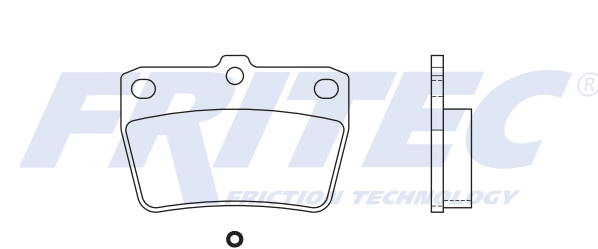
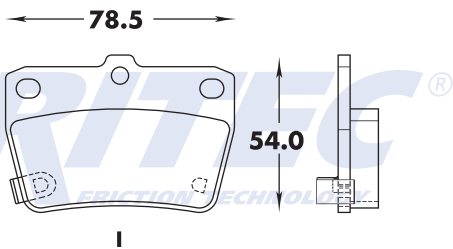

454

7957-Z1 D1095

D/F	T/R	E/T
X		15.6

7957-Z1 D1095

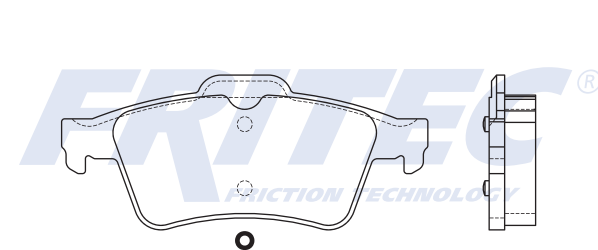
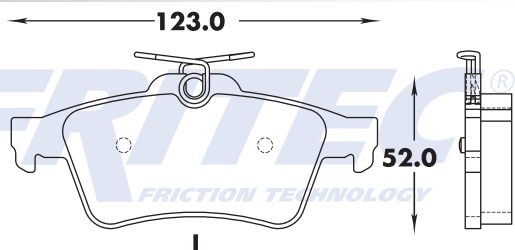

455

7958-Z D1053

D/F	T/R	E/T
X		14.6

7958-Z D1053

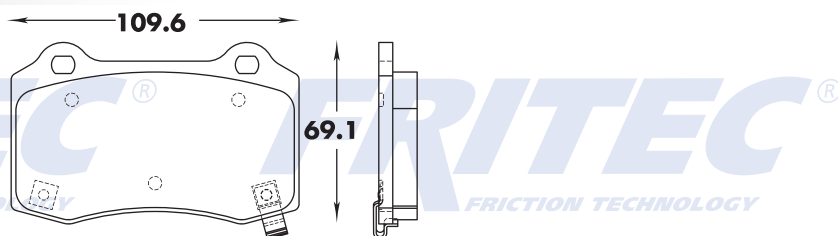

456

7961-Z D1055

D/F	T/R	E/T
X		17.0

7961-Z D1055

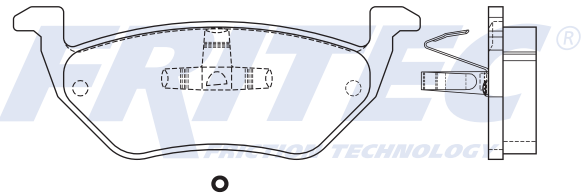
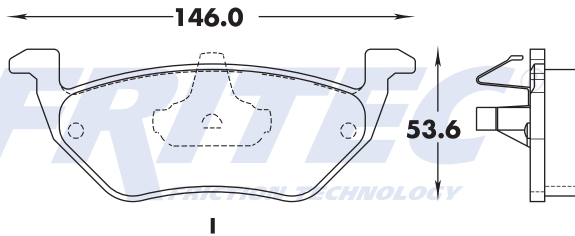

457

7962-Z D1056

D/F	T/R	E/T
X		18.0

7962-Z D1056

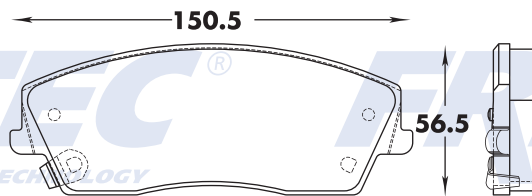

458

7963-Z D1057

D/F	T/R	E/T
X		17.2

7963-Z D1057

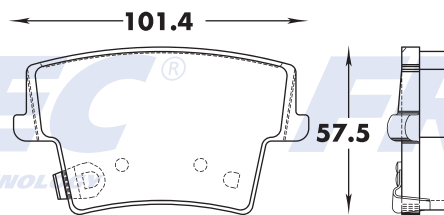

459

7965-Z D1058

D/F	T/R	E/T
X		17.3

7965-Z D1058

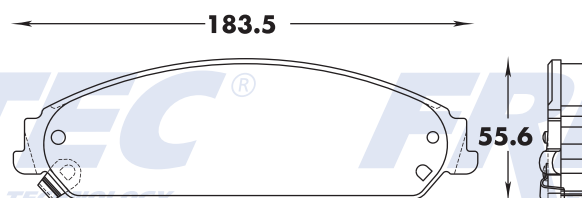

460

7967-Z D1061

D/F	T/R	E/T
X		19.0, 19.4

7967-Z D1061

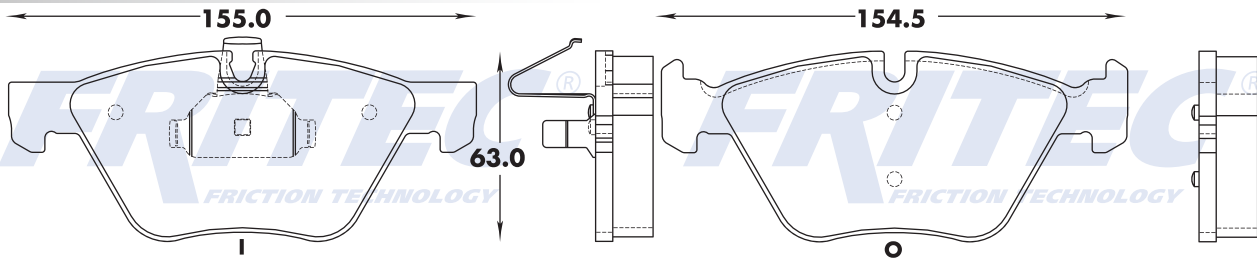

461

7973-Z D1067

D/F	T/R	E/T
X		18.0

7973-Z D1067

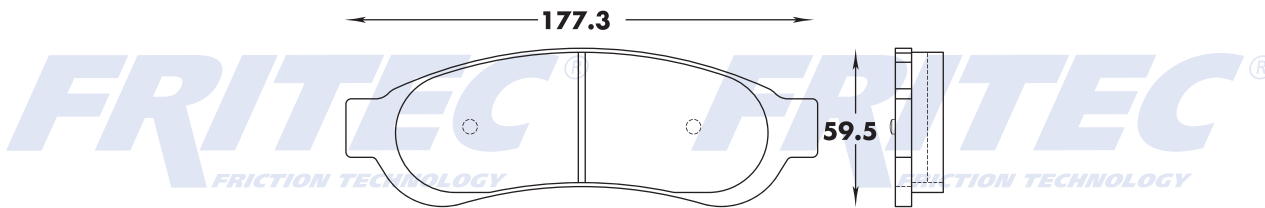

462

7973-Z1 D1068

D/F	T/R	E/T
X		18.0

7973-Z1 D1068

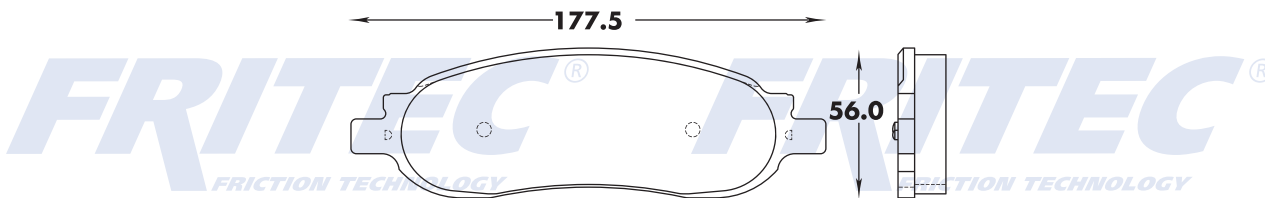

463

7973-Z2 D1334

D/F	T/R	E/T
X		18.0

7973-Z2 D1334

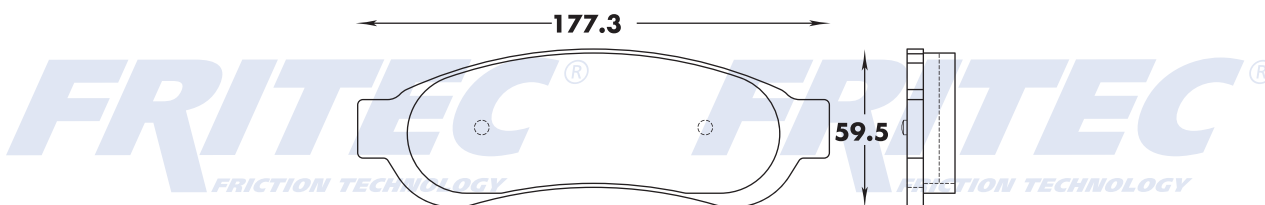

464

7974-Z D1069

D/F	T/R	E/T
X		20.6

7974-Z D1069

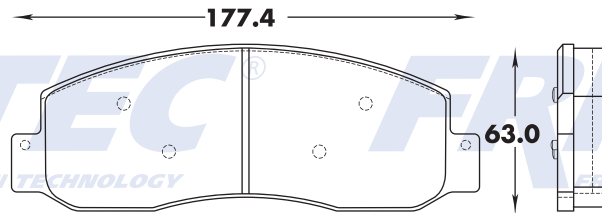

465

7974-Z1 D1333

D/F	T/R	E/T
X		20.5

7974-Z1 D1333

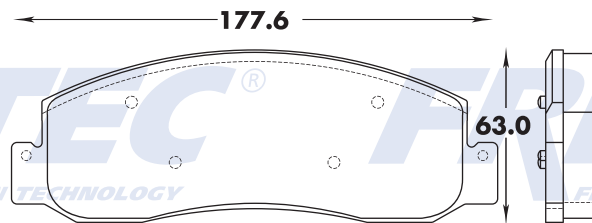

466

7975-Z D1070

D/F	T/R	E/T
X		16.9

7975-Z D1070

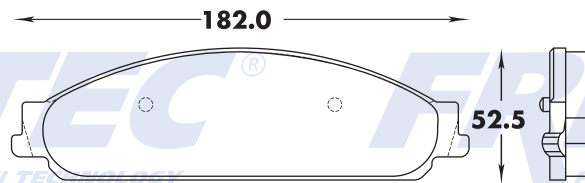

467

7976-Z D1071

D/F	T/R	E/T
X		16.2

7976-Z D1071

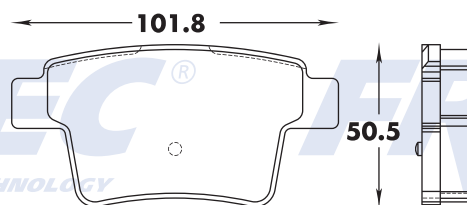

468

7980-Z D1075

D/F	T/R	E/T
X		16.9

7980-Z D1075

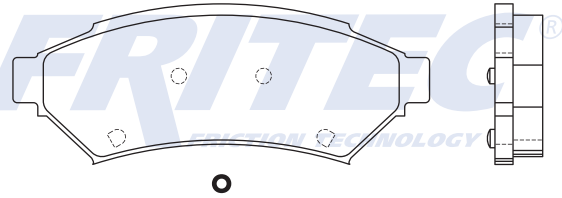
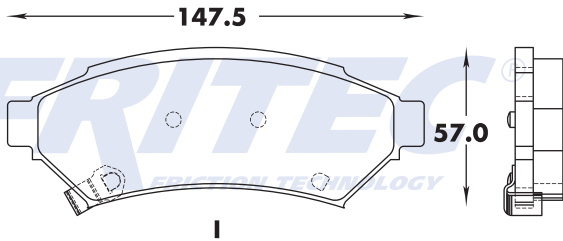

469

7983-Z D1078

D/F	T/R	E/T
X		17.1

7983-Z D1078

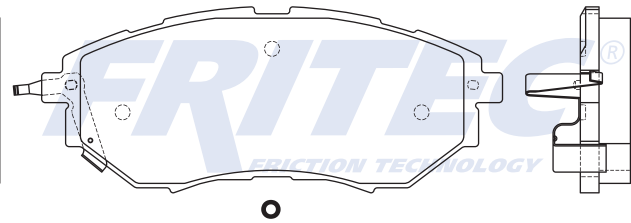
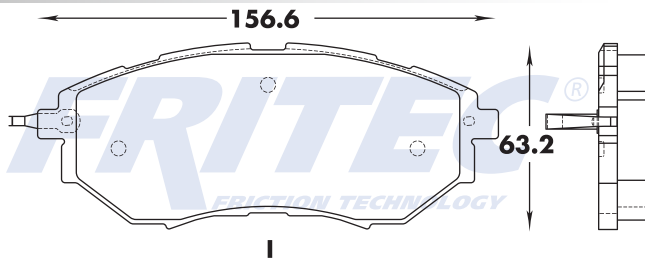

470

7984-Z D1079

D/F	T/R	E/T
X		17.5

7984-Z D1079

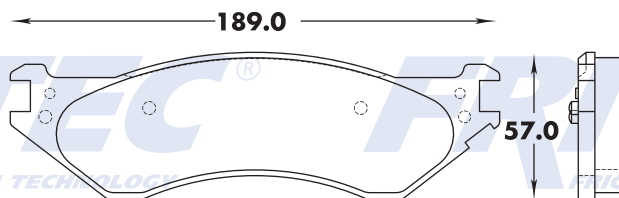

471

7985-Z D1080

D/F	T/R	E/T
X		18.0

7985-Z D1080

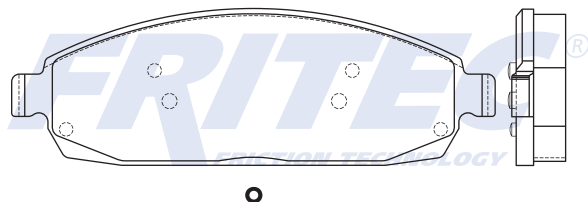
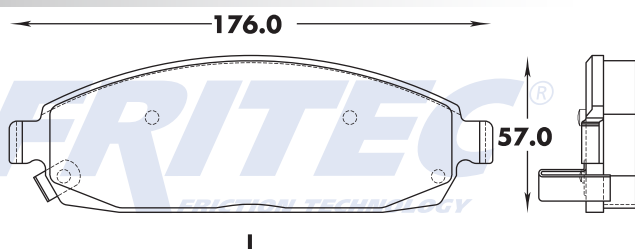

472

7986-Z D1081

D/F	T/R	E/T
X		17.0

7986-Z D1081

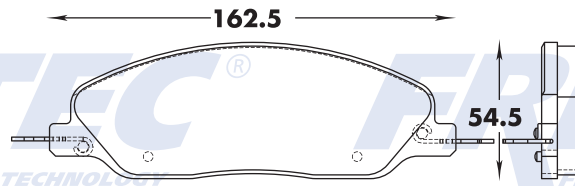

473

7987-Z D1082

D/F	T/R	E/T
X		16.6

7987-Z D1082

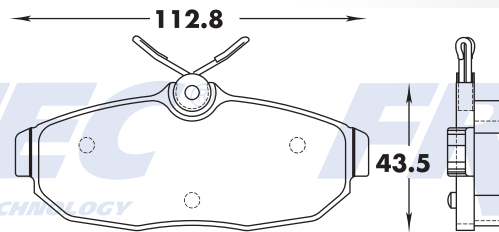

474

7991-Z D1084

D/F	T/R	E/T
X		17.7

7991-Z D1084

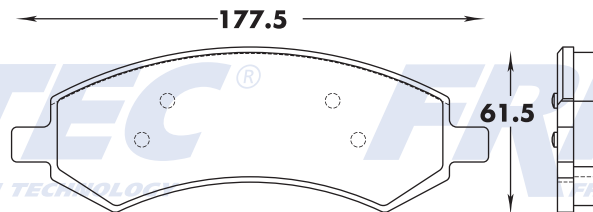

475

7992-Z D1085

D/F	T/R	E/T
X		15.9

7992-Z D1085

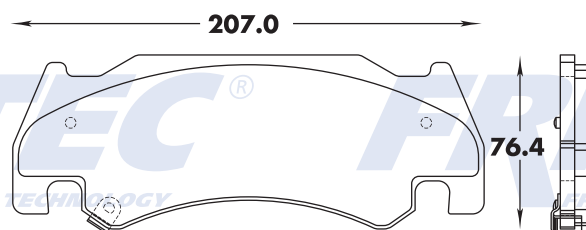

476

7993-Z D1088

D/F	T/R	E/T
X		15.4

7993-Z D1088

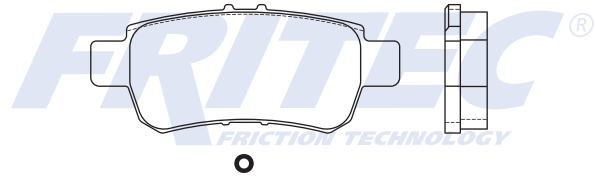
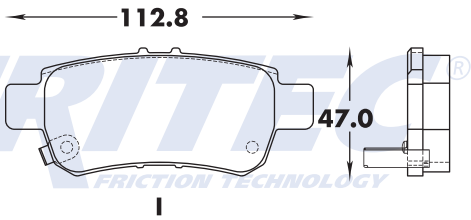

477

7994-Z1 D1521

D/F	T/R	E/T
X		17.9

7994-Z1 D1521

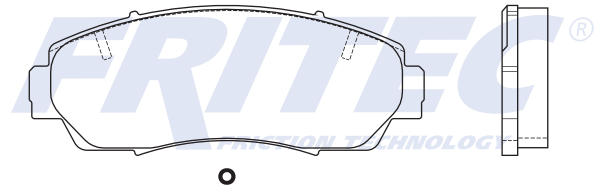
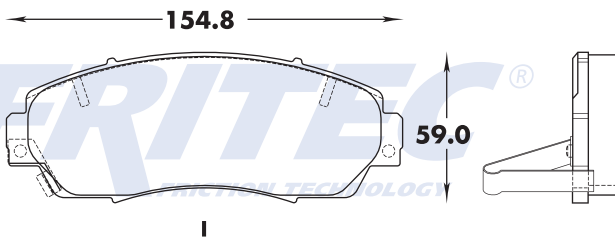

478

7997-Z D1092

D/F	T/R	E/T
X		18.0

7997-Z D1092

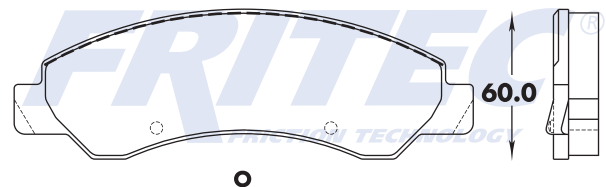
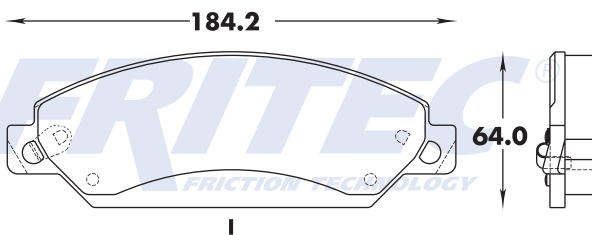

479

7999-Z D1093

D/F	T/R	E/T
X		14.0

7999-Z D1093

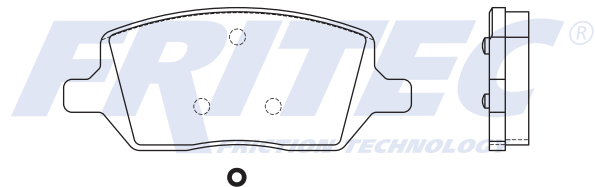
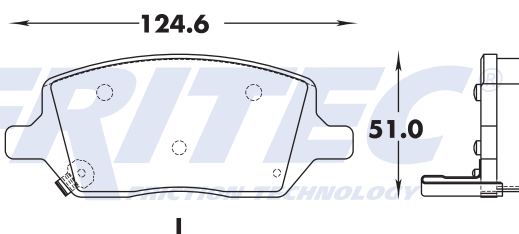

480

8383-Z D1268

D/F	T/R	E/T
X		20.0

8383-Z D1268

169.1

73.5

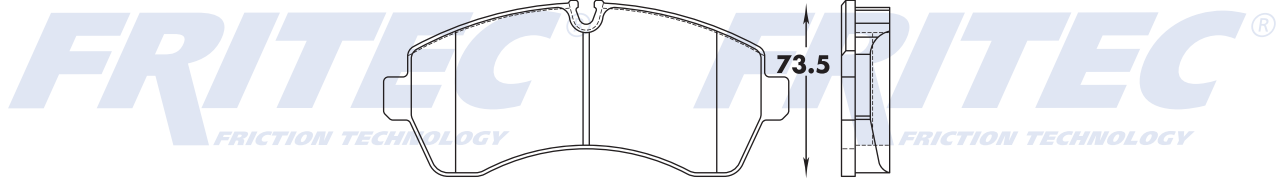

481

79W3A-Z F314

D/F	T/R	E/T
X		20.0

79W3A-Z F314

169.1

x 2

73.5

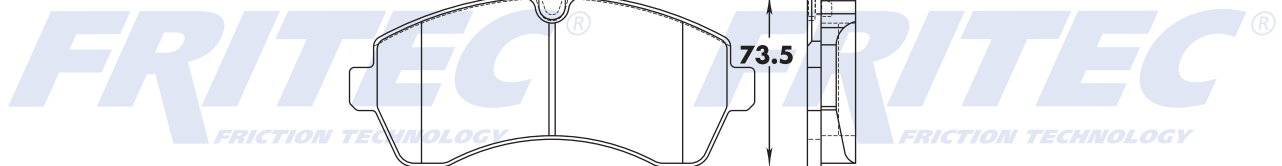

482

8432-Z D1318

D/F	T/R	E/T
X		20.0

8432-Z D1318

165.0

78.5

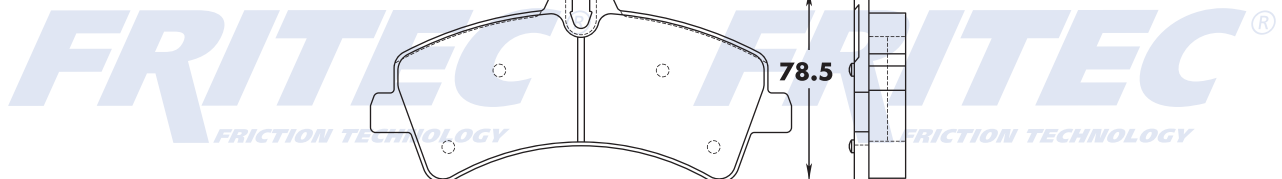

483

79W4A-Z F315

D/F	T/R	E/T
X		20.0

79W4A-Z F315

165.0

x 2

78.5

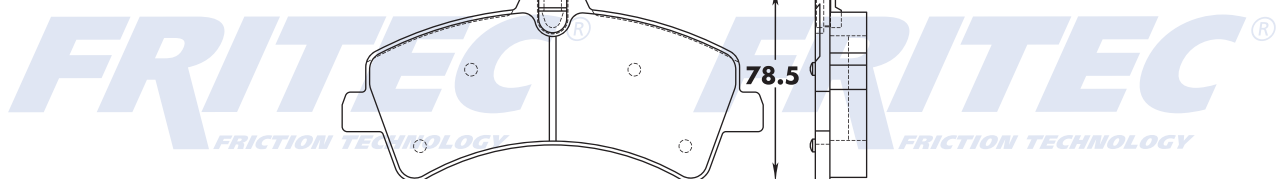

484

7W04-Z F498

D/F	T/R	E/T
X		17.5

7W04-Z F498

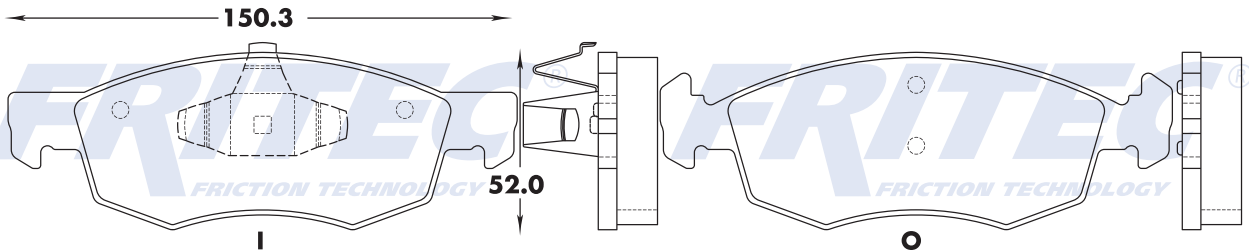

485

7X3-Z F012

D/F	T/R	E/T
X		16.3

7X3-Z F012

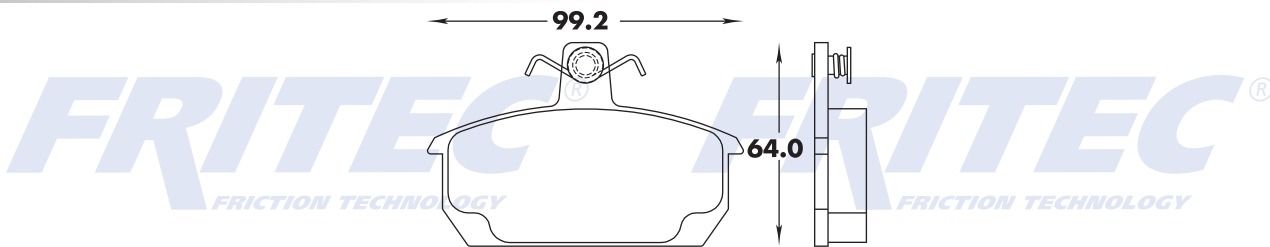

486

8258-Z D1148

D/F	T/R	E/T
X		15.9

8258-Z D1148

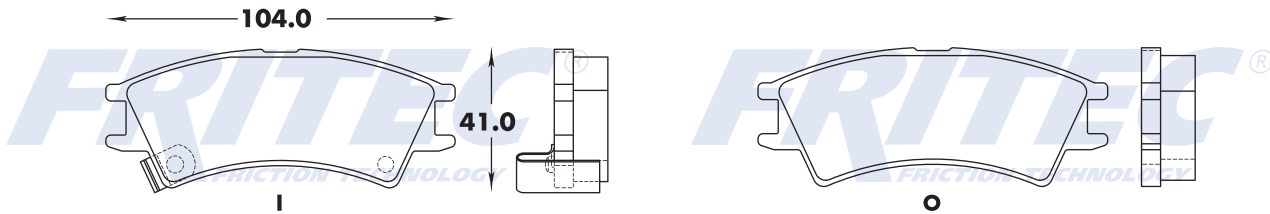

487

8831-Z D1619

D/F	T/R	E/T
X		17.0

8831-Z D1619

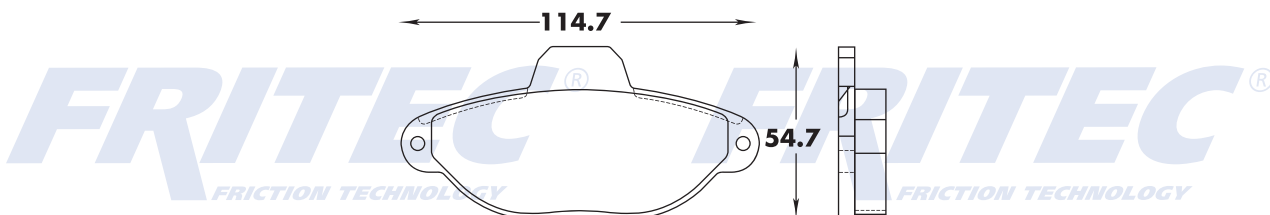

488

7X48-Z F126

D/F	T/R	E/T
X		16.8

7X48-Z F126

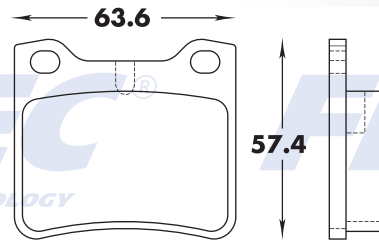

489

735-Z D30

D/F	T/R	E/T
X		15.0

735-Z D30

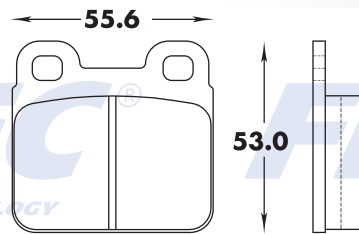

490

8247-Z D1137

D/F	T/R	E/T
X		17.9

8247-Z D1137

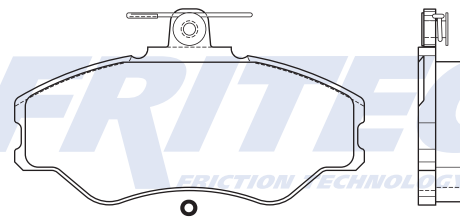
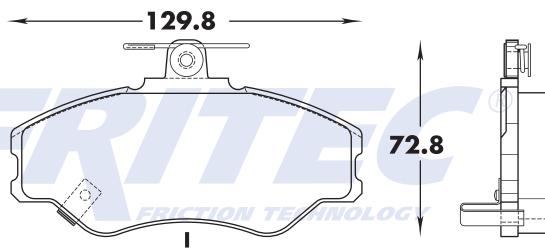

491

7X54-Z D298

D/F	T/R	E/T
X		17.8

7X54-Z D298

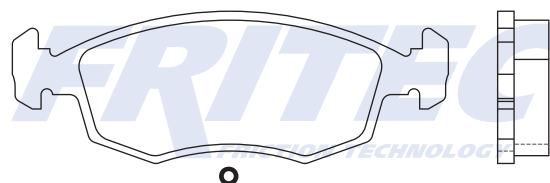
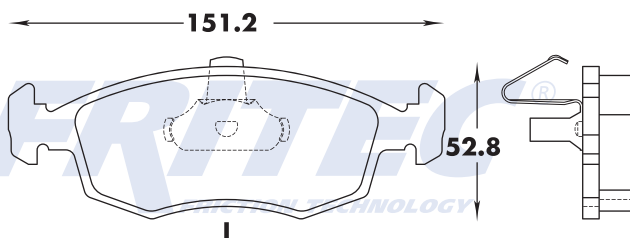

492

7X54-Z D298

D/F	T/R	E/T
X		17.8

7X54-Z D298

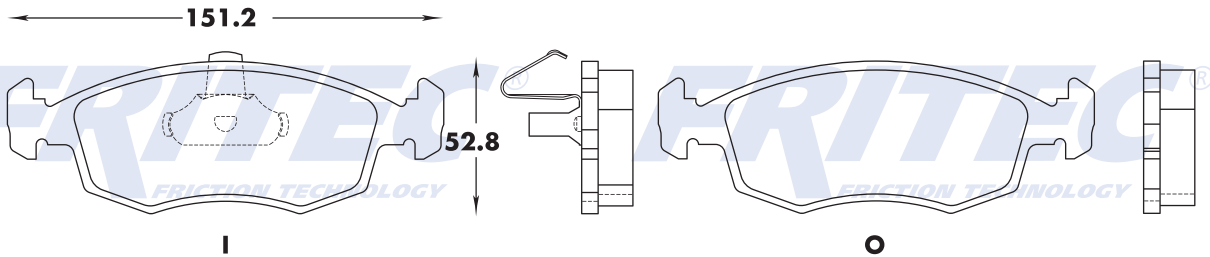

493

7X54A-Z D298

D/F	T/R	E/T
X		17.8

7X54A-Z D298

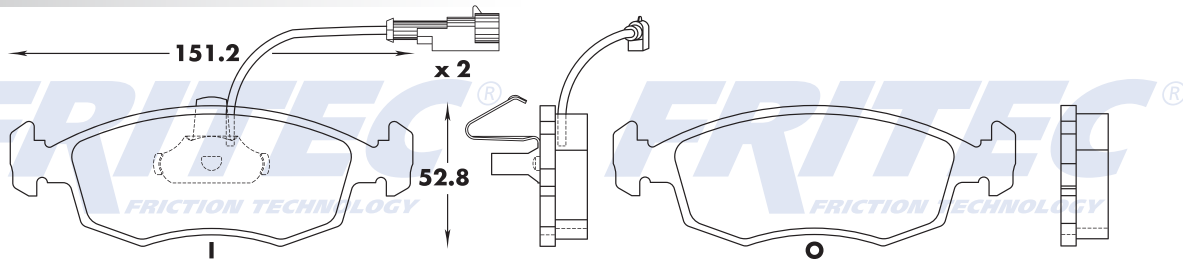

494

7X56-Z F103

D/F	T/R	E/T
X		17.3

7X56-Z F103

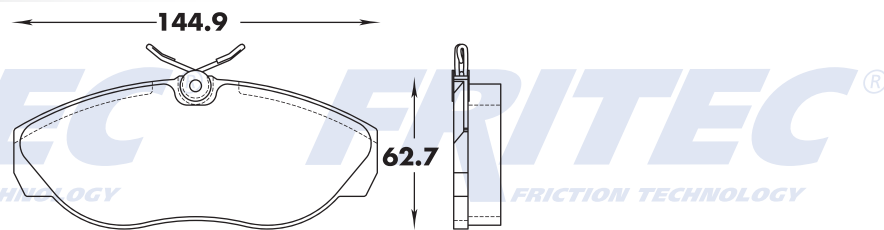

495

7X59-Z F015

D/F	T/R	E/T
X		17.3

7X59-Z F015

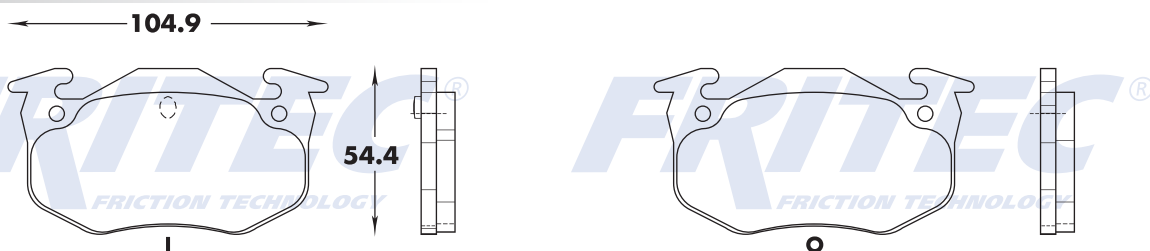

496

7612-Z D742

D/F	T/R	E/T
X		18.2

7612-Z D742

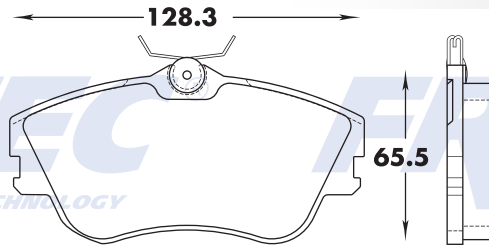

497

7729-Z D852

D/F	T/R	E/T
X		18.2

7729-Z D852

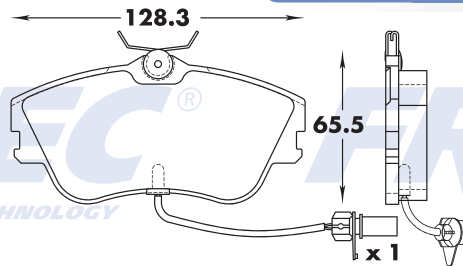

498

7177-Z D227

D/F	T/R	E/T
X		15.2

7177-Z D227

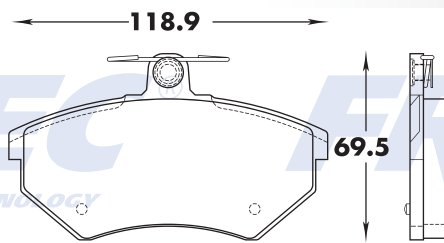

499

7X83-Z D569

D/F	T/R	E/T
X		19.4, 19.8

7X83-Z D569

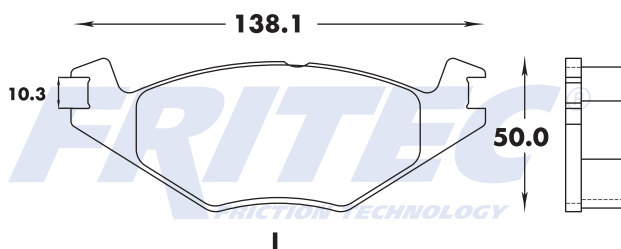

I



O

500

8255-Z D1145

D/F	T/R	E/T
X		17.0

8255-Z D1145

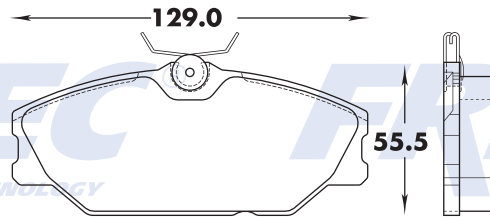

501

8253-Z D1142

D/F	T/R	E/T
X		15.9

8253-Z D1142

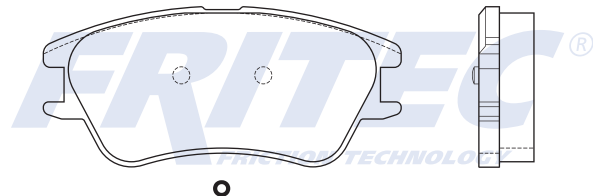
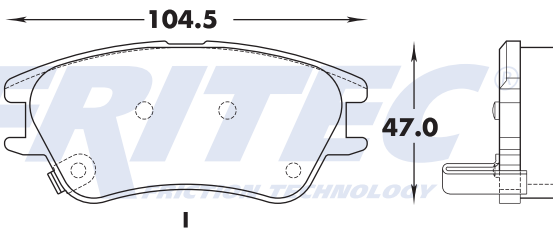

502

8290-Z D1176

D/F	T/R	E/T
X		16.3

8290-Z D1176

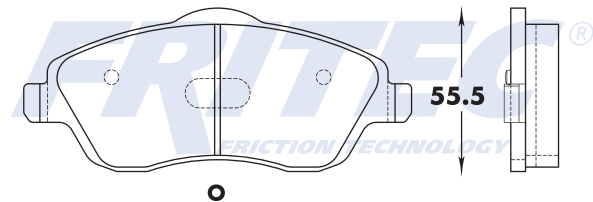
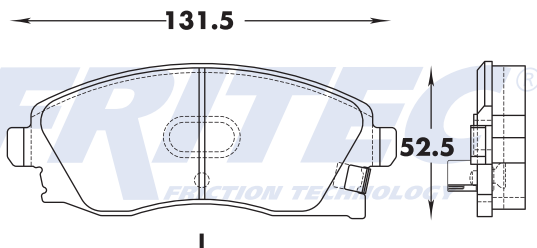

503

7Y06-Z F219

D/F	T/R	E/T
X		19.3

7Y06-Z F219

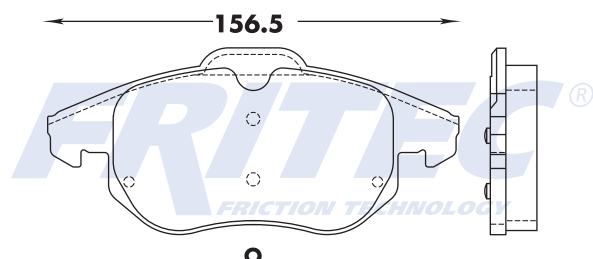
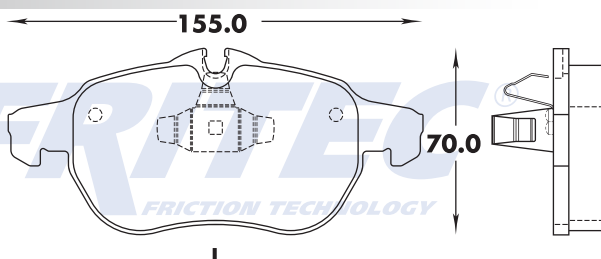

504

7Y08-Z F221

D/F	T/R	E/T
X		18.3

7Y08-Z F221

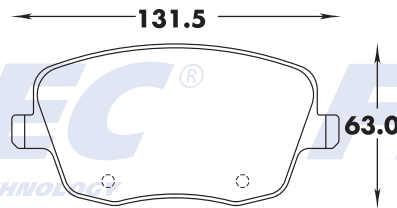

505

8289-Z D1175

D/F	T/R	E/T
X		17.7

8289-Z D1175

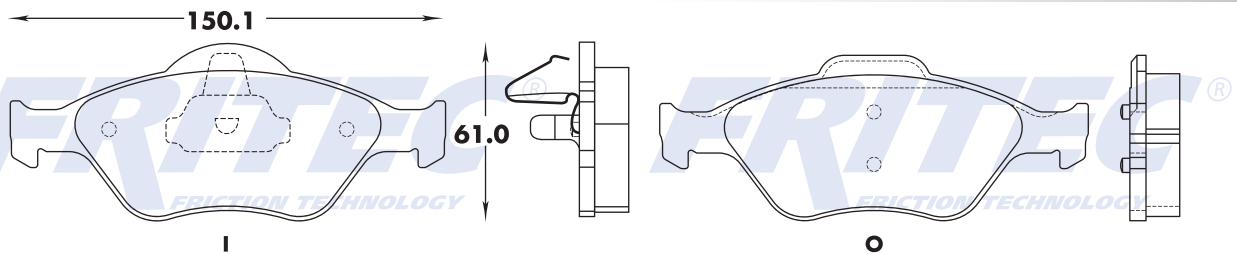

506

7Y10-Z F232

D/F	T/R	E/T
X		19.9

7Y10-Z F232

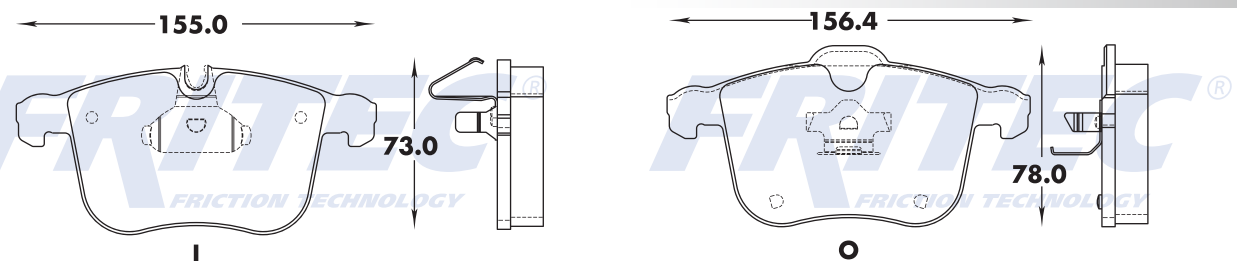

507

7Y10A-Z F232

D/F	T/R	E/T
X		19.9

7Y10A-Z F232

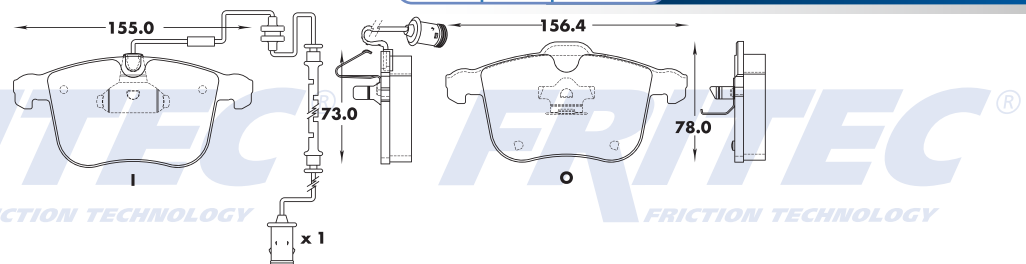

508

7Y13-Z F244

D/F	T/R	E/T
X		17.3

7Y13-Z F244

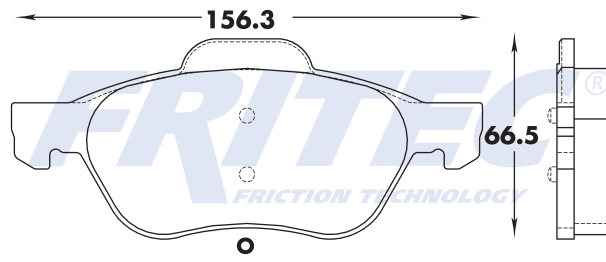
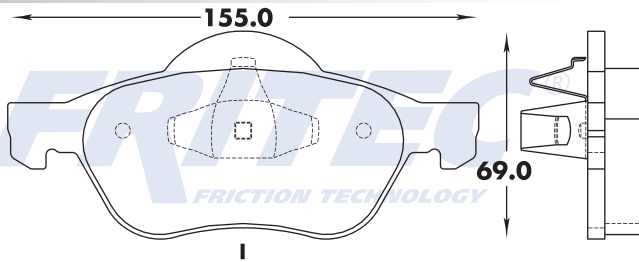

509

7Y14-Z F245

D/F	T/R	E/T
X		18.2

7Y14-Z F245

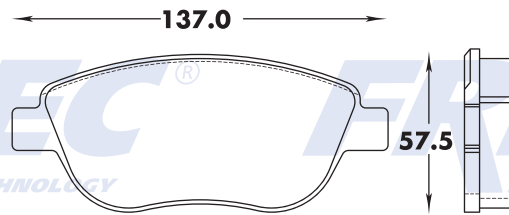

510

8311-Z D1193

D/F	T/R	E/T
X		15.4

8311-Z D1193

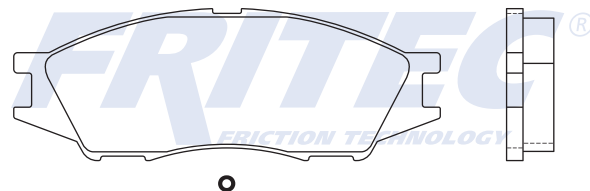
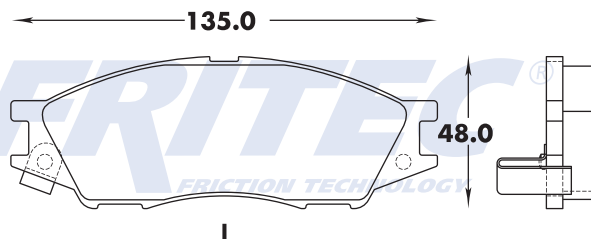

511

7Y21-Z F253

D/F	T/R	E/T
X		18.0

7Y21-Z F253

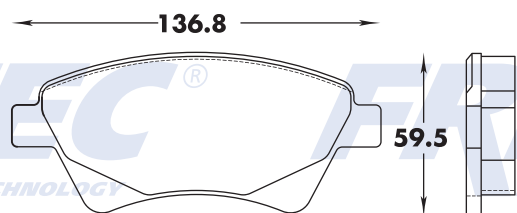

512

8553-Z D1435

D/F	T/R	E/T
X		16.8

8553-Z D1435

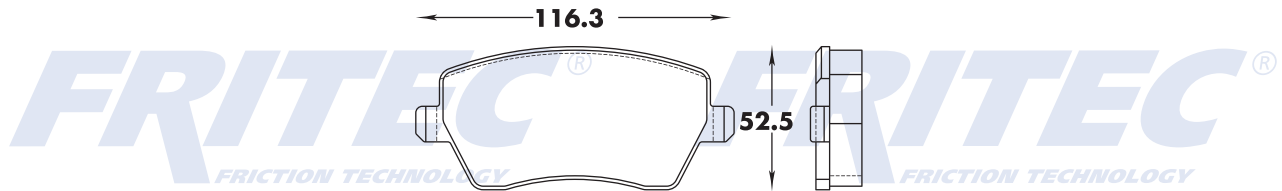

513

8455-Z D1344

D/F	T/R	E/T
X		15.5

8455-Z D1344

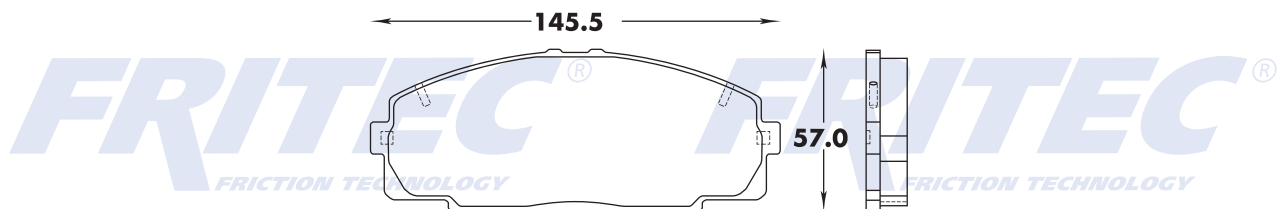

514

7Y31-Z F235

D/F	T/R	E/T
X		15.0

7Y31-Z F235

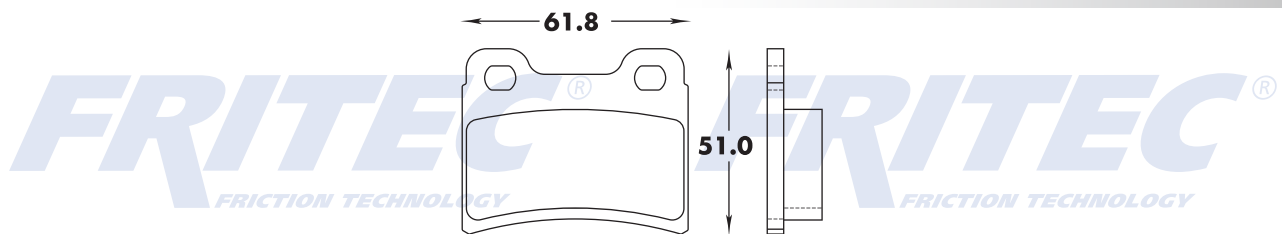

515

8336-Z D1216

D/F	T/R	E/T
X		16.0

8336-Z D1216

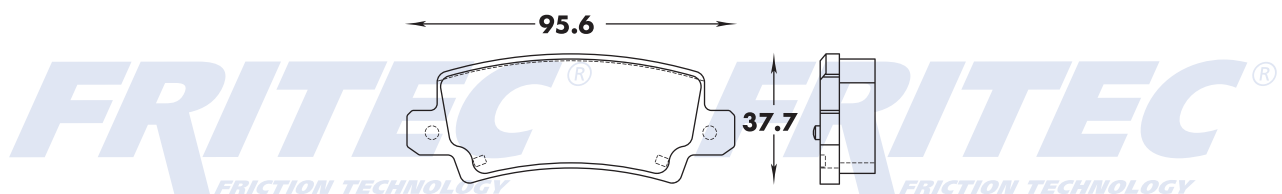

516

7Y35-Z F278

D/F	T/R	E/T
X		15.7

7Y35-Z F278

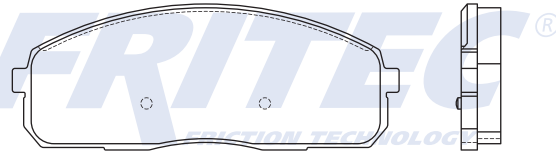
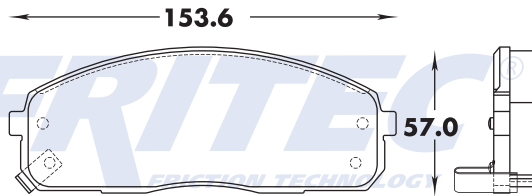

517

7Y43-Z F317

D/F	T/R	E/T
X		18.0

7Y43-Z F317

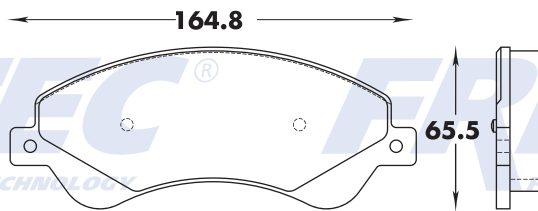

518

8736-Z D1528

D/F	T/R	E/T
X		18.0

8736-Z D1528

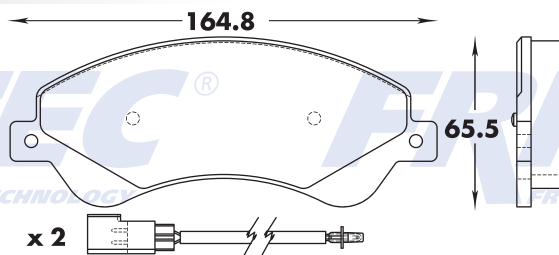

519

8671-Z D1471

D/F	T/R	E/T
X		14.0

8671-Z D1471

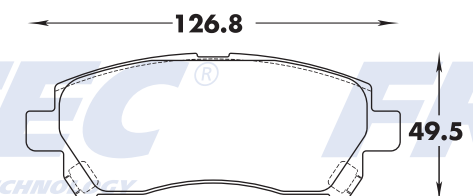

520

8815-Z D1601

D/F	T/R	E/T
X		15.9

8815-Z D1601

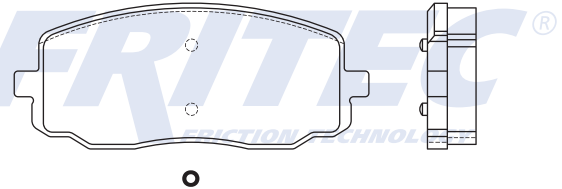
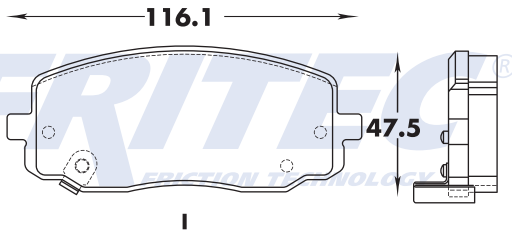

521

7Y46-Z F338

D/F	T/R	E/T
X		17.3

7Y46-Z F338

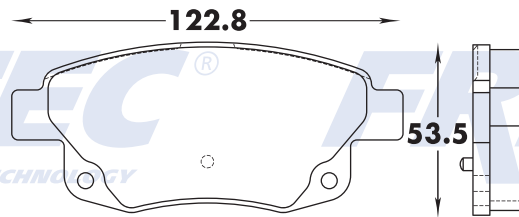

522

8701-Z D1502

D/F	T/R	E/T
X		17.3

8701-Z D1502

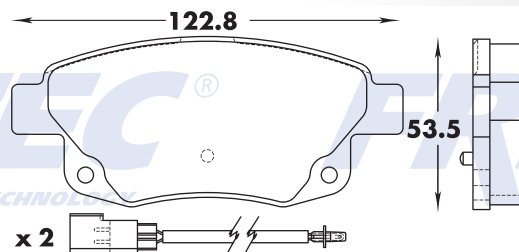

523

7Y49-Z F324

D/F	T/R	E/T
X		14.0

7Y49-Z F324

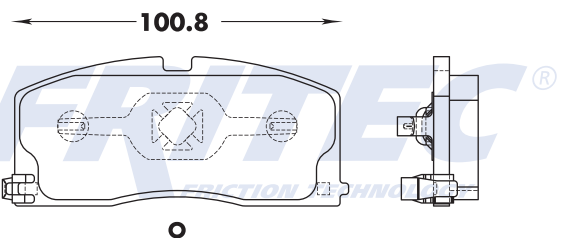
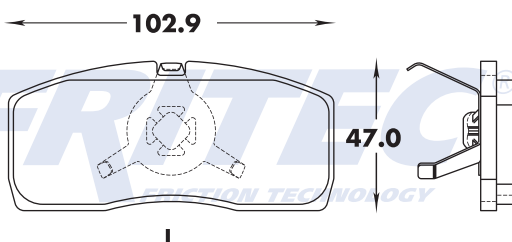

524

8728-Z D1519

D/F	T/R	E/T
X		16.0

8728-Z D1519

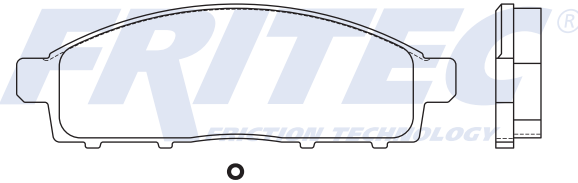
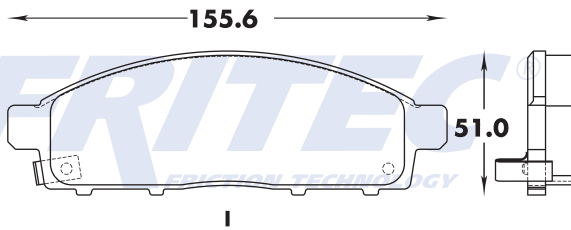

525

8775-Z D1566

D/F	T/R	E/T
X		17.5

8775-Z D1566

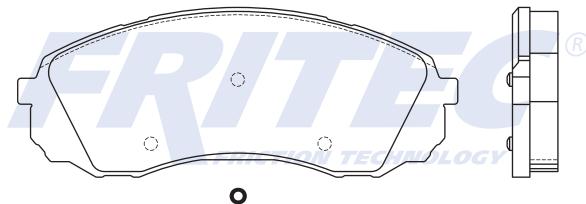
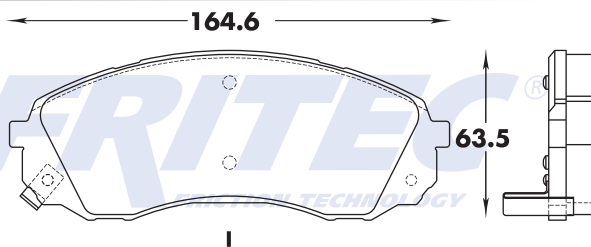

526

8780-Z D1571

D/F	T/R	E/T
X		18.2

8780-Z D1571

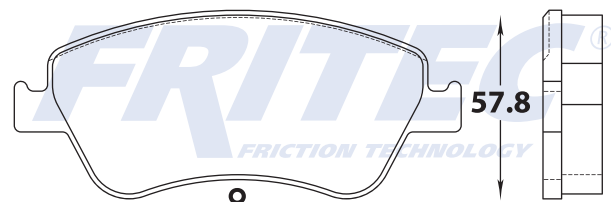
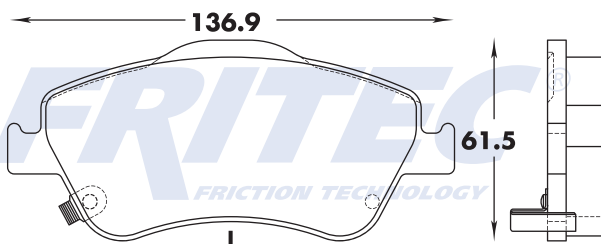

527

8781-Z D1572

D/F	T/R	E/T
X		15.0

8781-Z D1572

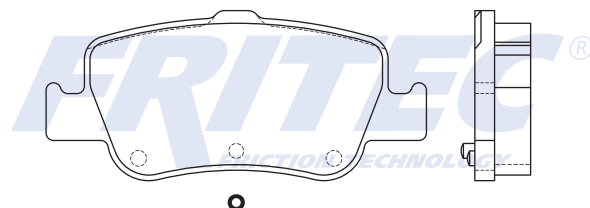
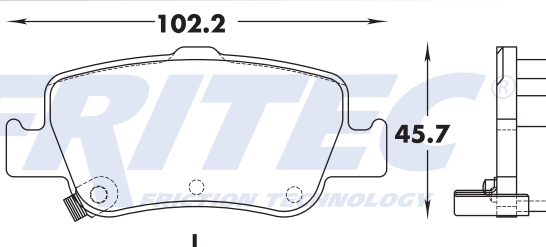

528

7Y55-Z F533

D/F	T/R	E/T
X		16.7

7Y55-Z F533

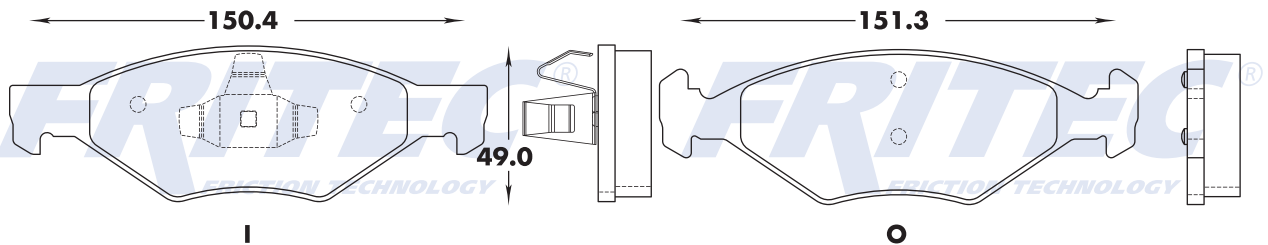

529

8827-Z D1614

D/F	T/R	E/T
X		15.0

8827-Z D1614

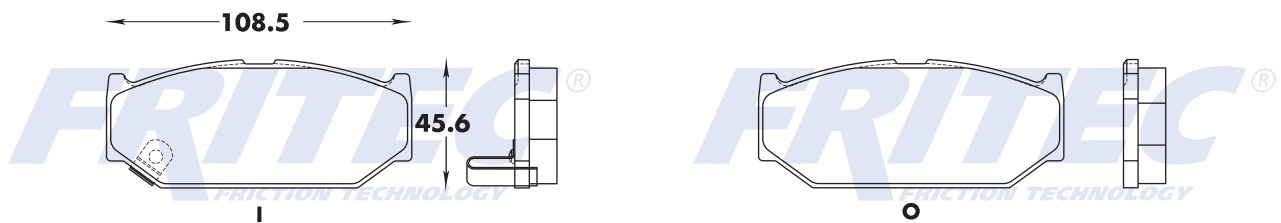

530

8926-Z D1702

D/F	T/R	E/T
X		16.9

8926-Z D1702

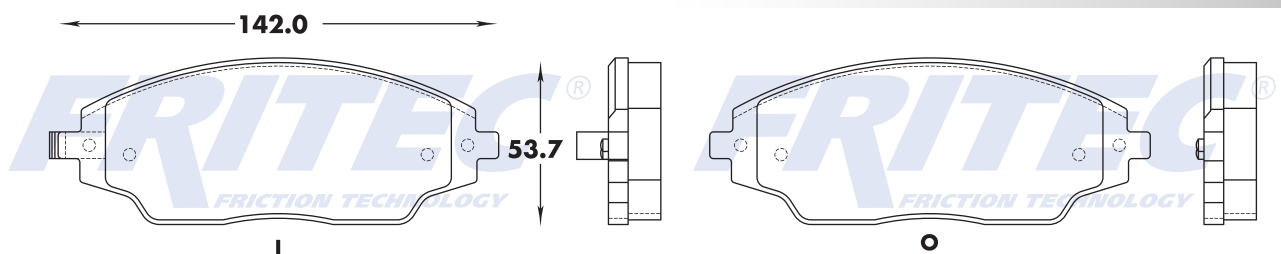

531

7Y81-Z F327

D/F	T/R	E/T
X		16.0

7Y81-Z F327

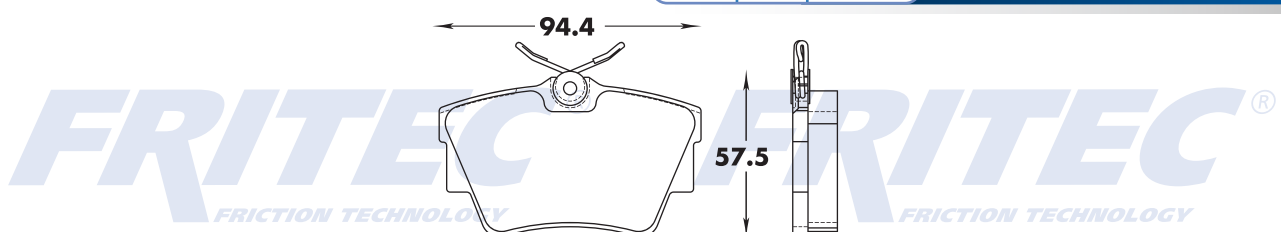

532

7Y84-Z F262

D/F	T/R	E/T
X		18.5

7Y84-Z F262

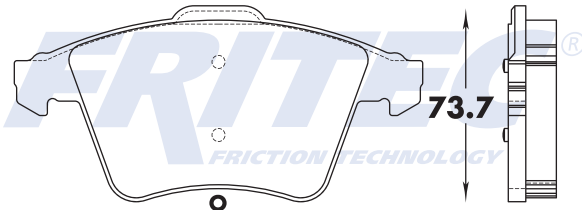
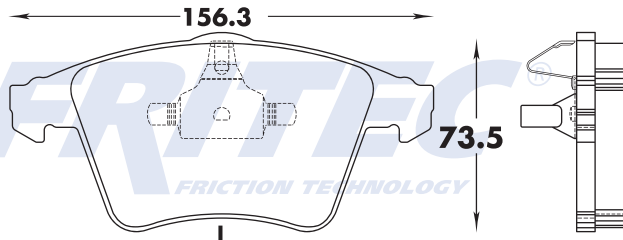

533

7Y84A-Z F262

D/F	T/R	E/T
X		18.5

7Y84A-Z F262

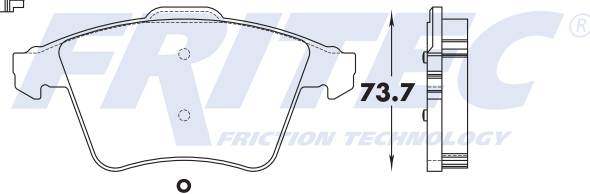
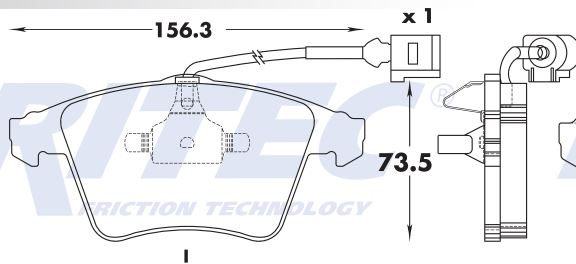

534

8748-Z D1540

D/F	T/R	E/T
X		19.0

8748-Z D1540

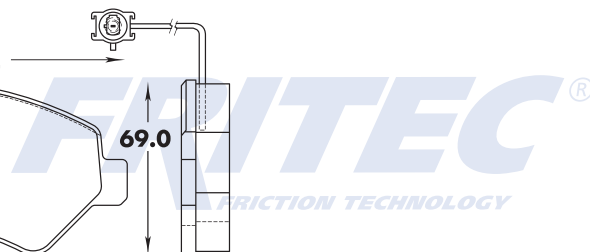
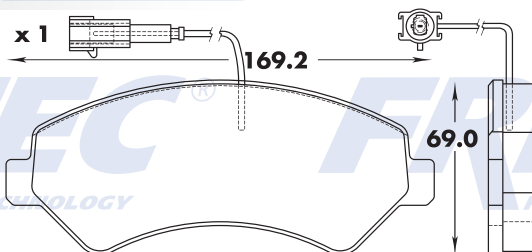

535

7Y87-Z F222

D/F	T/R	E/T
X		18.8

7Y87-Z F222

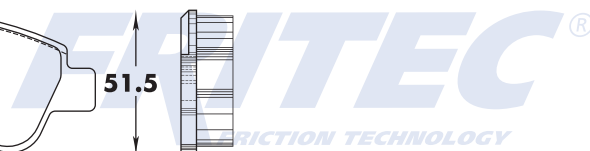
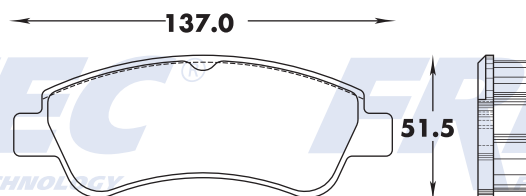

536

8674-Z D1475

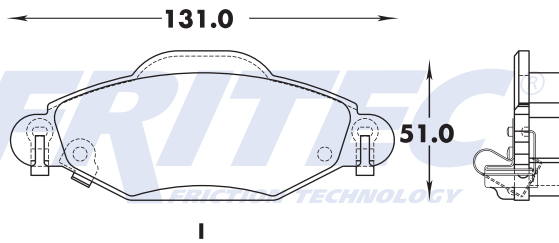

D/F	T/R	E/T
X		16.2

8674-Z D1475

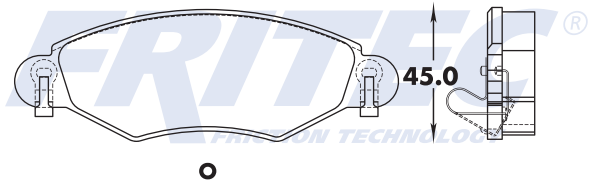

537

8456-Z D1345

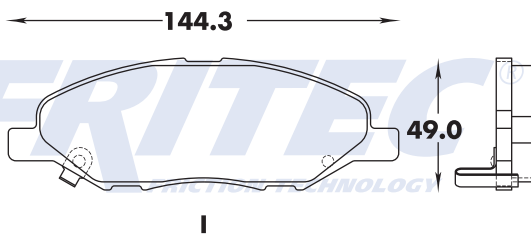

D/F	T/R	E/T
X		14.4

8456-Z D1345

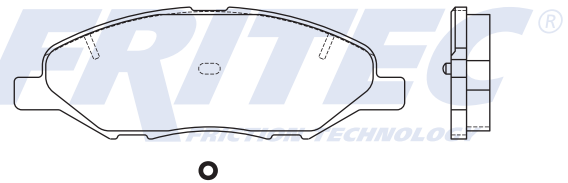

538

8200-Z D1094

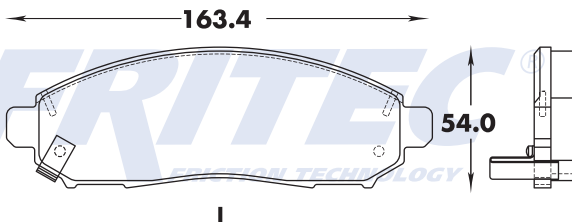

D/F	T/R	E/T
X		15.9

8200-Z D1094

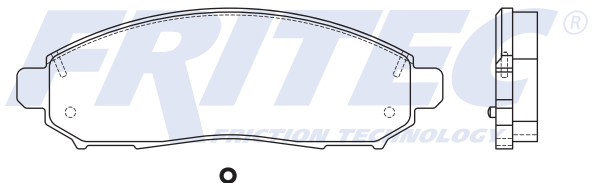

539

8204-Z D1101

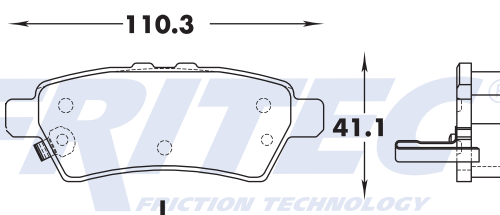

D/F	T/R	E/T
X		15.9

8204-Z D1101

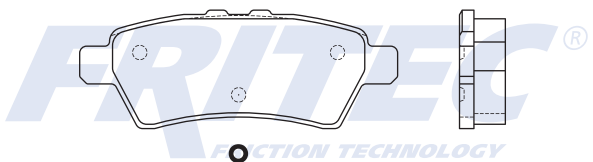

540

8206-Z D1100

D/F	T/R	E/T
X		15.9

8206-Z D1100

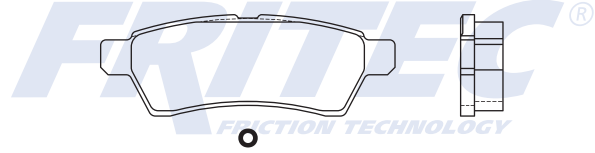
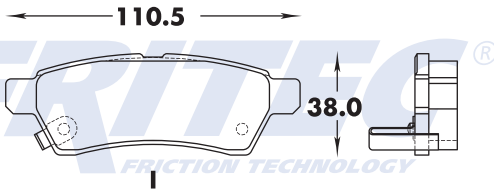

541

8207-Z D922

D/F	T/R	E/T
X		13.1

8207-Z D922

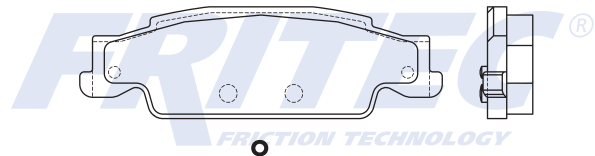
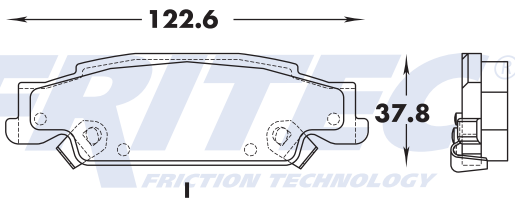

542

8208-Z D1102

D/F	T/R	E/T
X		18.0

8208-Z D1102

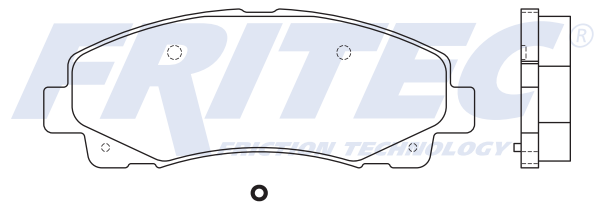
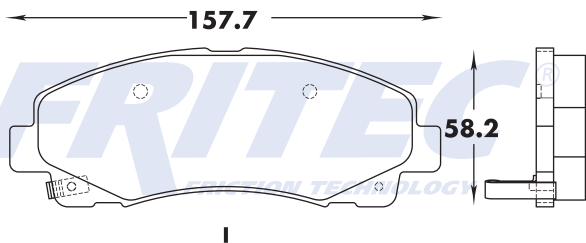

543

8209-Z D1103

D/F	T/R	E/T
X		15.3

8209-Z D1103

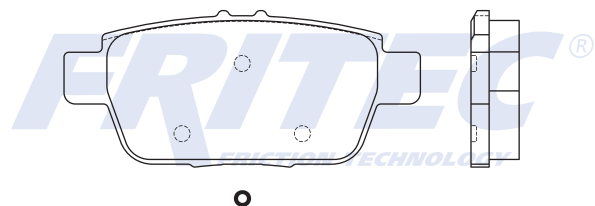
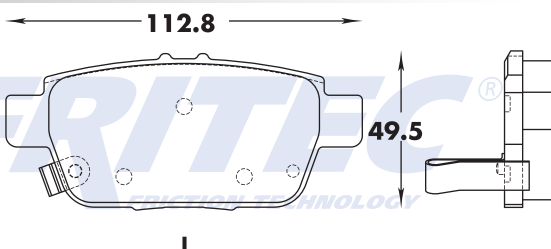

544

8212-Z D1107

D/F	T/R	E/T
X		19.3

8212-Z D1107

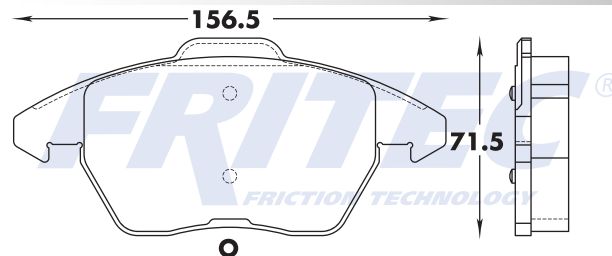
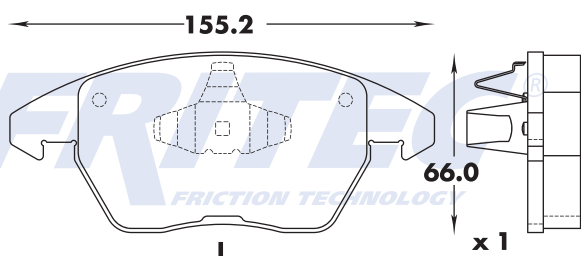

545

8213-Z D1108

D/F	T/R	E/T
X		16.0

8213-Z D1108

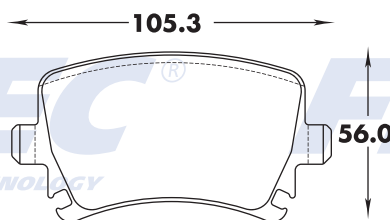

546

8214-Z D1109

D/F	T/R	E/T
X		15.0

8214-Z D1109

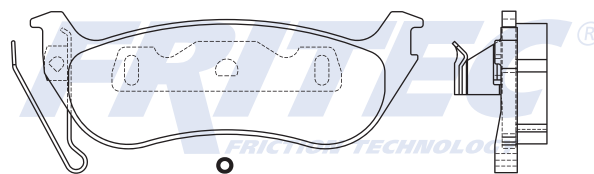
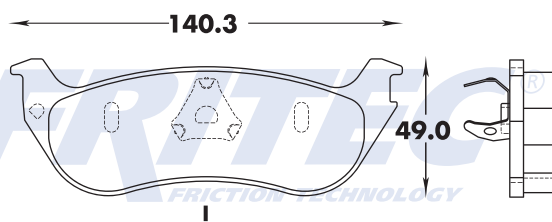

547

8218-Z D1114

D/F	T/R	E/T
X		13.8

8218-Z D1114

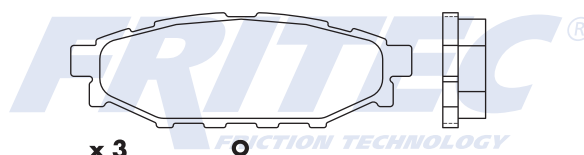
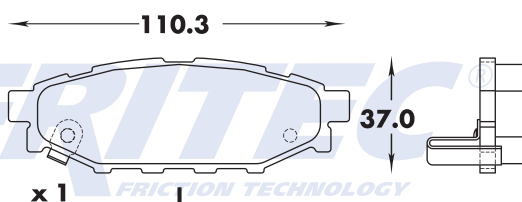

548

8220-Z D915

D/F	T/R	E/T
X		17.8

8220-Z D915

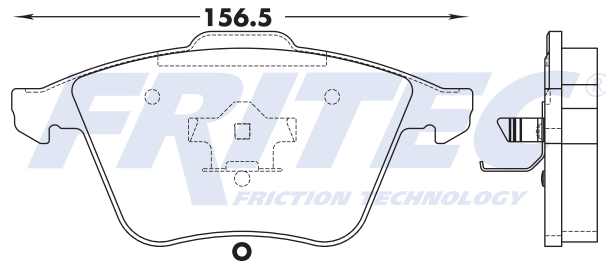
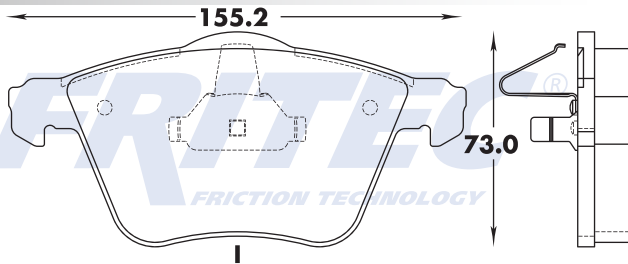

549

8221-Z D888

D/F	T/R	E/T
X		17.0

8221-Z D888

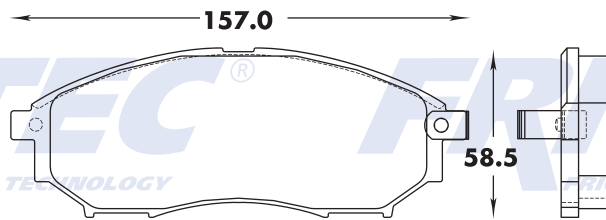

550

8225-Z D1119

D/F	T/R	E/T
X		16.8

8225-Z D1119

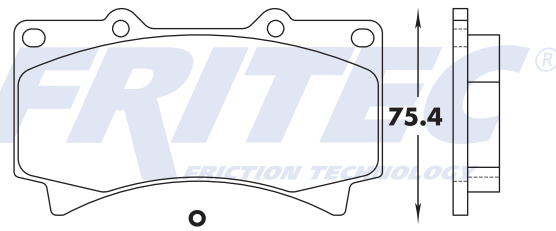
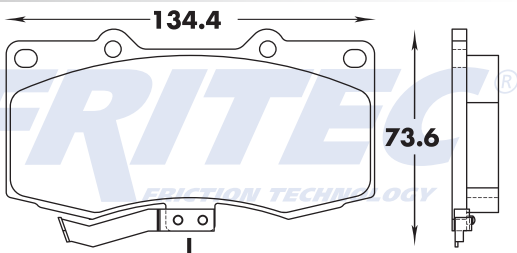

551

8226-Z D1120

D/F	T/R	E/T
X		15.4

8226-Z D1120

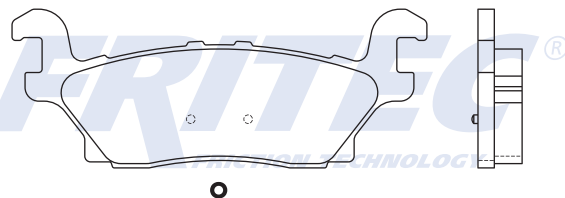
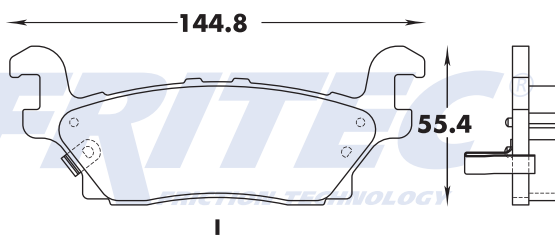

552

8231-Z D1124

D/F	T/R	E/T
X		16.0

8231-Z D1124

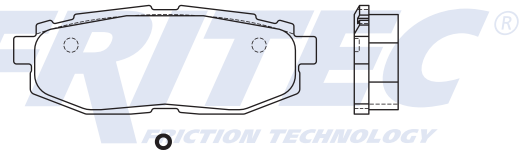
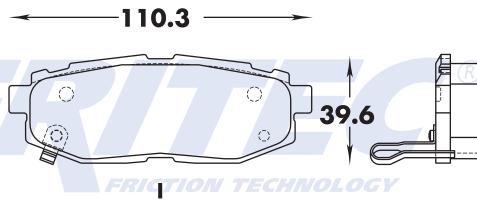

553

8238-Z D1129

D/F	T/R	E/T
X		15.8

8238-Z D1129

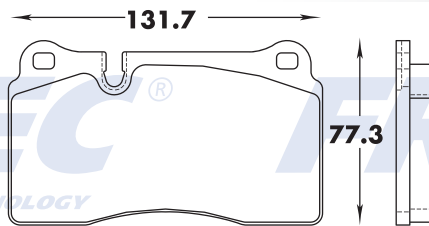

554

8259-Z D1149

D/F	T/R	E/T
X		16.6

8259-Z D1149

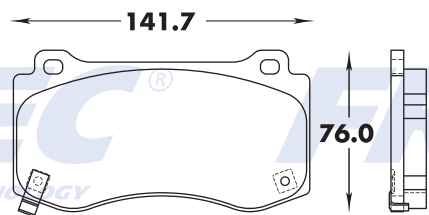

555

8266-Z D1156

D/F	T/R	E/T
X		16.9

8266-Z D1156

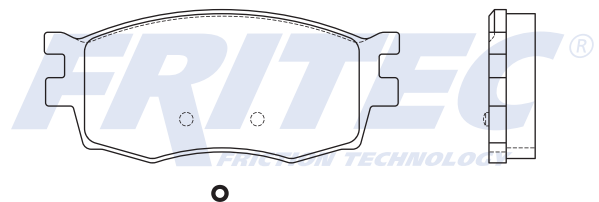
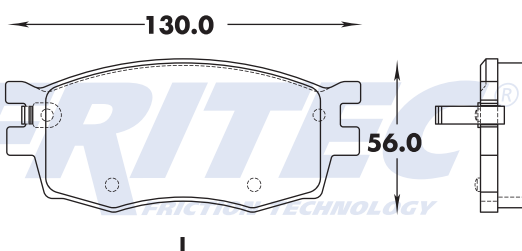

556

8267-Z D1157

D/F	T/R	E/T
X		15.0

8267-Z D1157

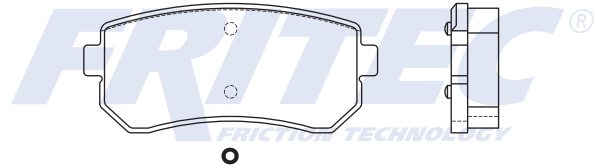
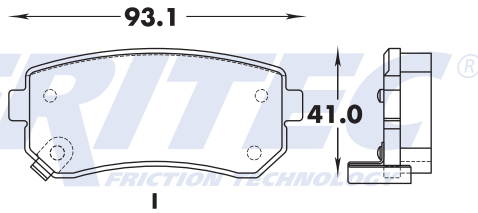

557

8268-Z D1158

T/R	E/T
X	11.6

8268-Z D1158

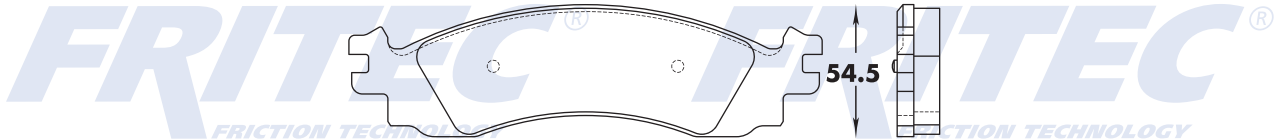
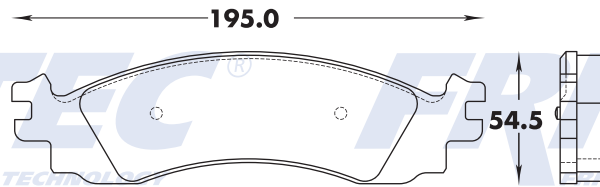

558

8269-Z D1159

D/F	T/R	E/T
X		16.3

8269-Z D1159

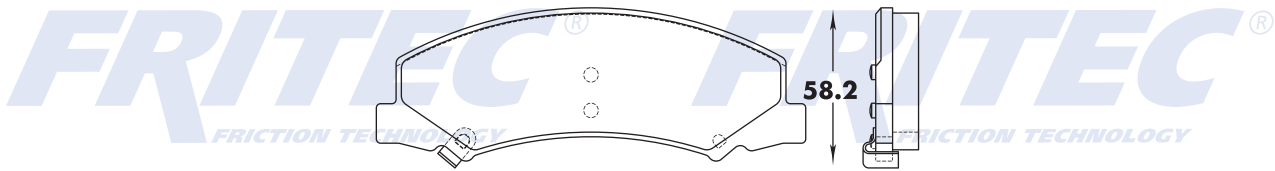
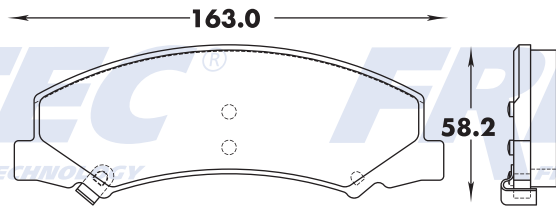

559

8270-Z D1160

D/F	T/R	E/T
X		17.2

8270-Z D1160

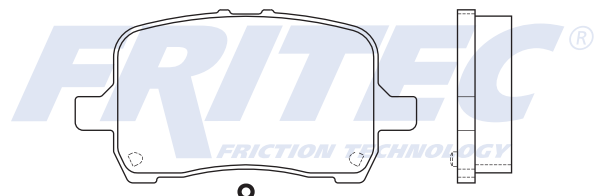
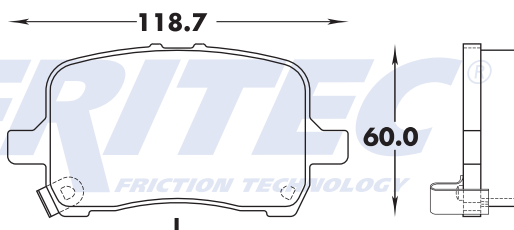

560

8272-Z D1161

D/F	T/R	E/T
X		14.4

8231-Z D1124

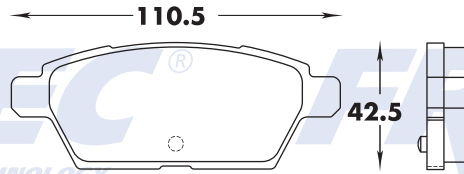

561

8277-Z D1164

D/F	T/R	E/T
X		17.6

8277-Z D1164

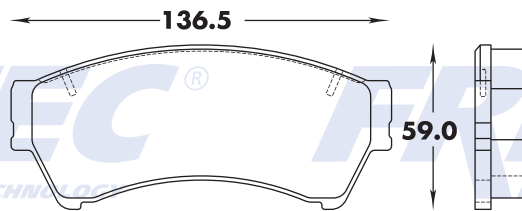

562

8282-Z D1169

D/F	T/R	E/T
X		17.8

8282-Z D1169

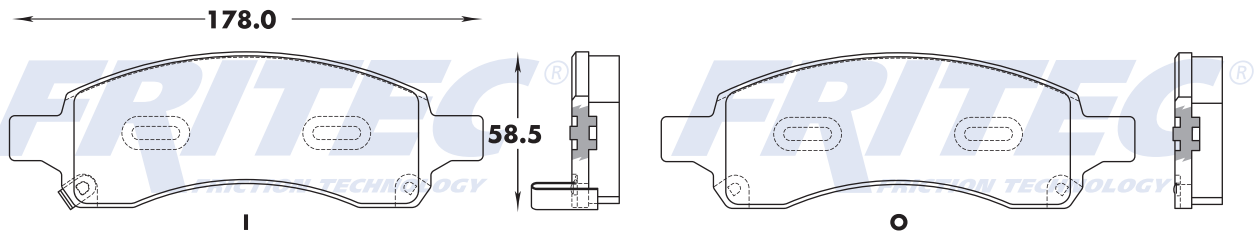

563

8292-Z D1057

D/F	T/R	E/T
X		14.9

8292-Z D1057

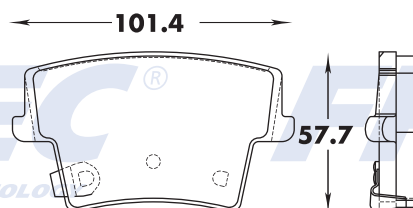

564

8295-Z D1179

D/F	T/R	E/T
X		14.4

8295-Z D1179

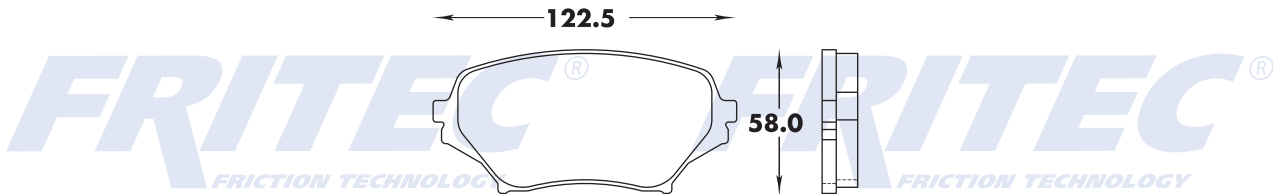

565

8297-Z D1181

D/F	T/R	E/T
X		18.0

8297-Z D1181

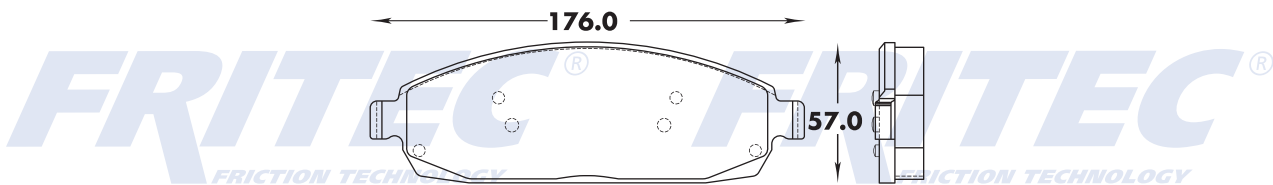

566

8300-Z D1183

D/F	T/R	E/T
X		17.7

8300-Z D1183

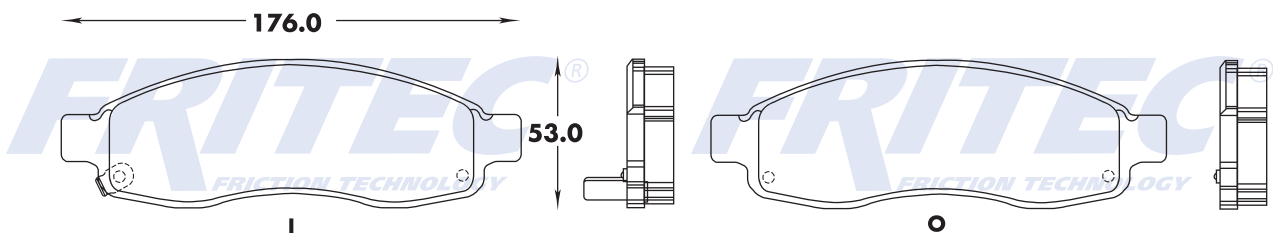

567

8301-Z D1184

D/F	T/R	E/T
X		17.5

8301-Z D1184

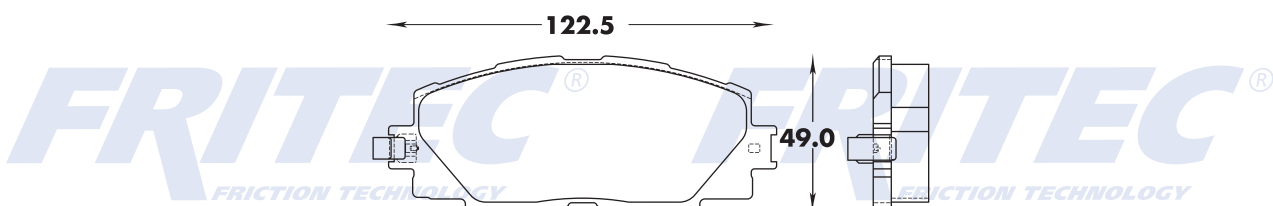

568

8307-Z D1188

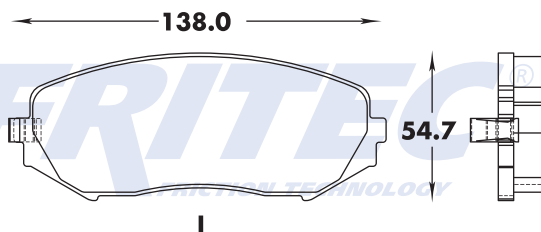

D/F	T/R	E/T
X		16.4

8307-Z D1188

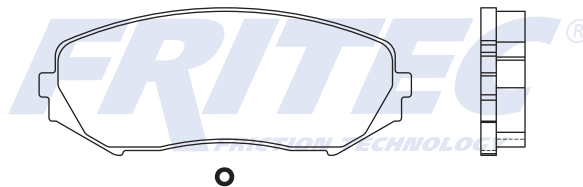

569

8312-Z D1194

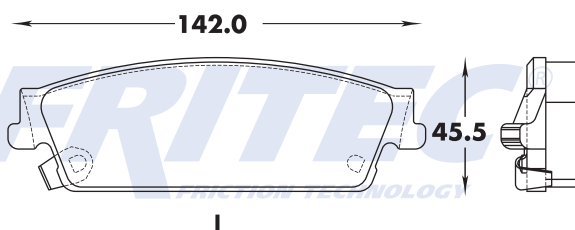

D/F	T/R	E/T
X		16.6

8312-Z D1194

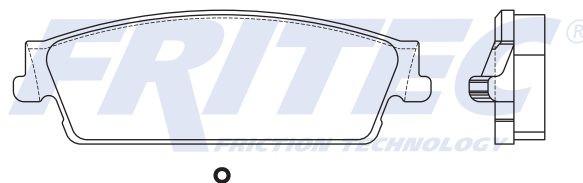

570

8314-Z D462

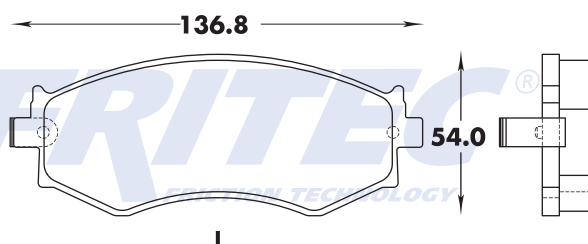

D/F	T/R	E/T
X		16.4

8314-Z D462

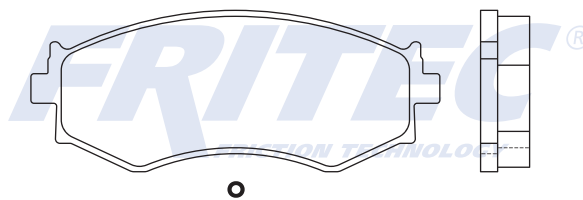

571

8315-Z D1195

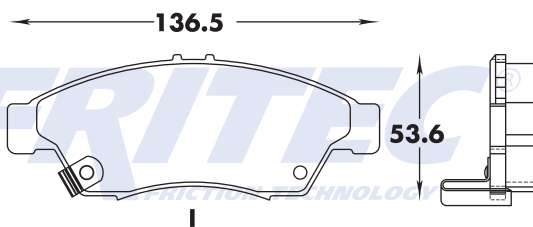

D/F	T/R	E/T
X		16.4

8315-Z D1195

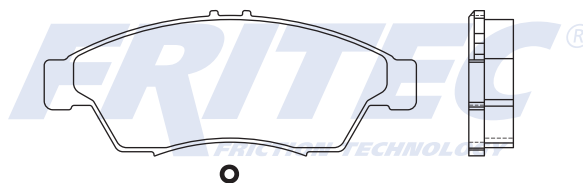

572

8320-Z D1200

D/F	T/R	E/T
X		14.4

8320-Z D1200

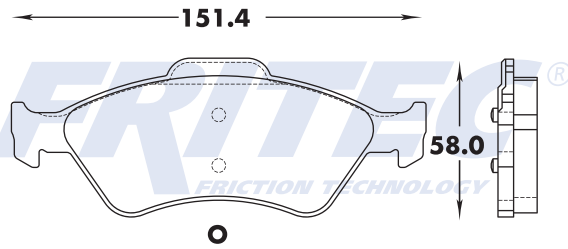
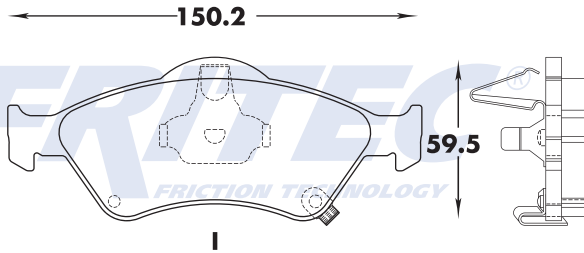

573

8324-Z D1204

D/F	T/R	E/T
X		17.1

8324-Z D1204

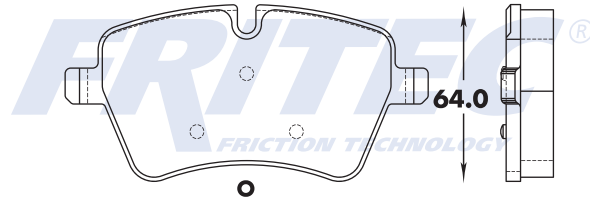
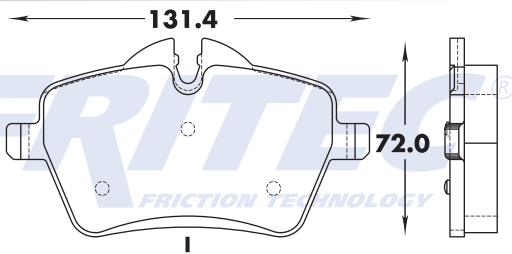

574

8330-Z D1210

D/F	T/R	E/T
X		17.5

8330-Z D1210

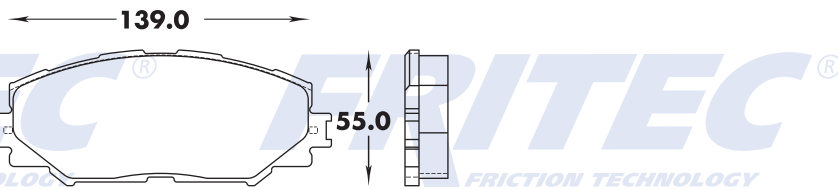

575

8331-Z D1211

D/F	T/R	E/T
X		17.6

8331-Z D1211

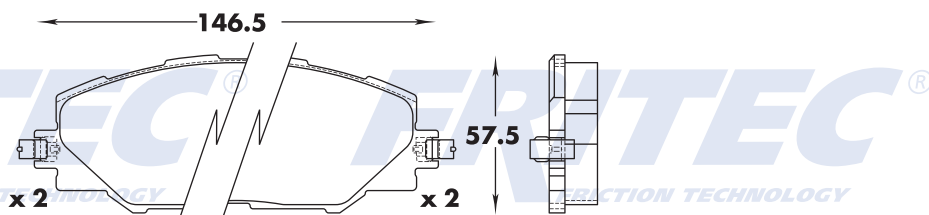

576

8331-Z2 D1293

D/F	T/R	E/T
X		17.5

8331-Z2 D1293

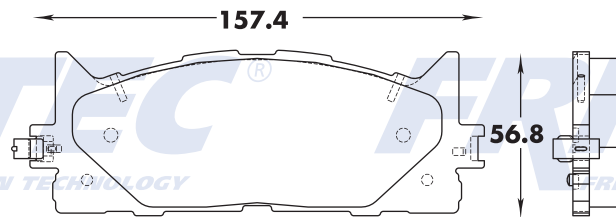

577

8332-Z D1212

D/F	T/R	E/T
X		15.4

8332-Z D1212

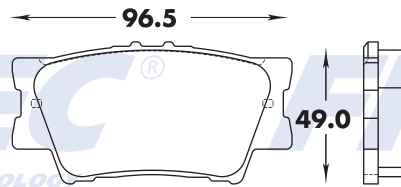

578

8333-Z D1213

D/F	T/R	E/T
X		18.1

8333-Z D1213

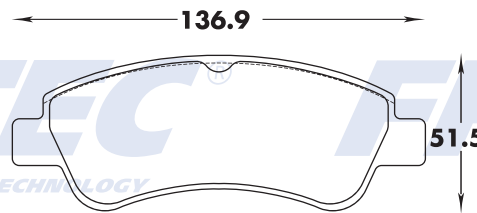

579

8338-Z D866

D/F	T/R	E/T
X		17.4

8338-Z D866

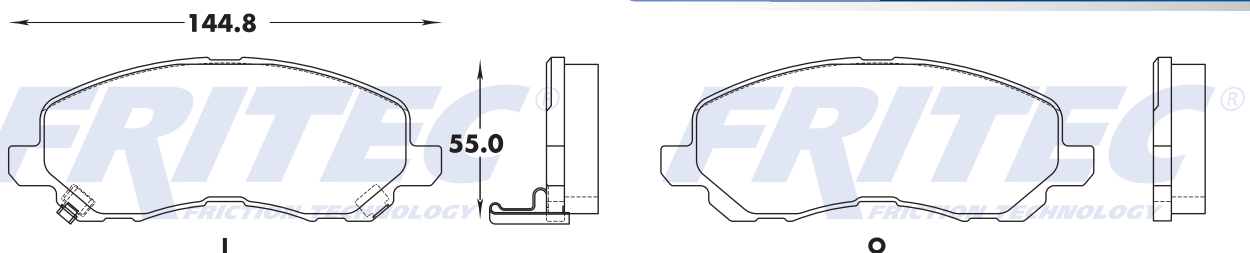

580

8357-Z D1305

D/F	T/R	E/T
X		19.2, 17.7

8357-Z D1305

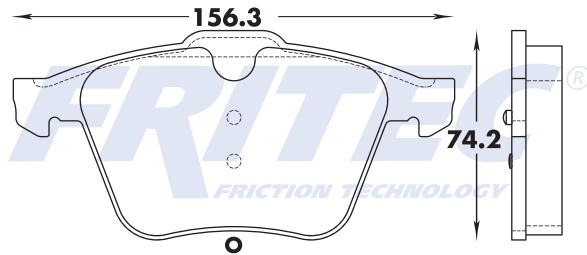
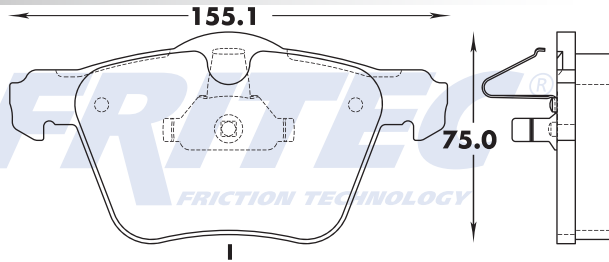

581

8362A-Z D1245

D/F	T/R	E/T
X		17.4

8362A-Z D1245

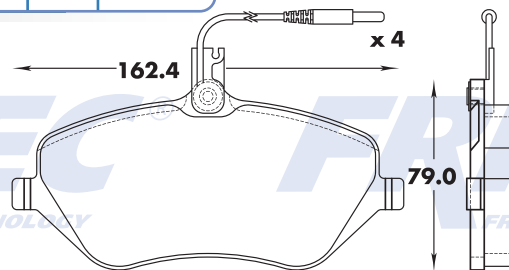

582

8366-Z D1014

D/F	T/R	E/T
X		15.3

8366-Z D1014

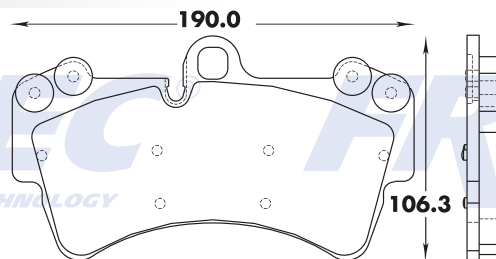

583

8377-Z D1258

D/F	T/R	E/T
X		17.4

8377-Z D1258

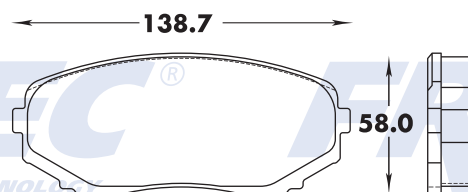

584

8378-Z D1259

D/F	T/R	E/T
X		16.9

8378-Z D1259

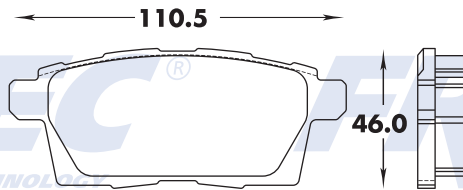

585

8380-Z D1263

D/F	T/R	E/T
X		16.5

8380-Z D1263

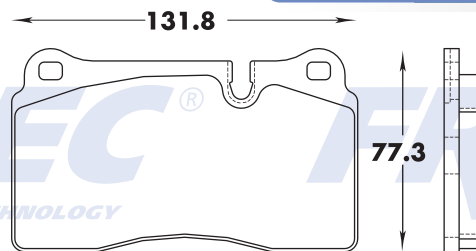

586

8381-Z D1264

D/F	T/R	E/T
X		16.5

8381-Z D1264

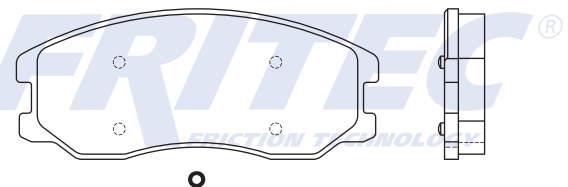
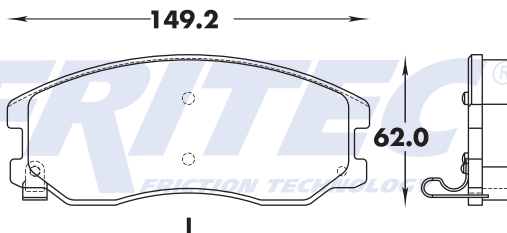

587

8385-Z D1269

D/F	T/R	E/T
X		16.4

8385-Z D1269

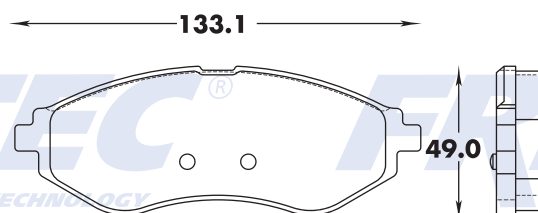

588

8389-Z D1273

D/F	T/R	E/T
X		16.6

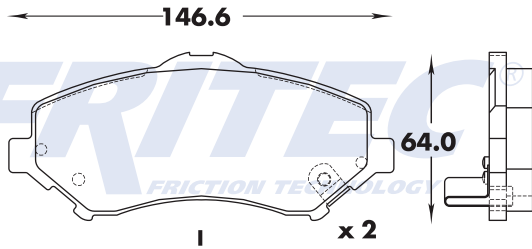

8389-Z D1273

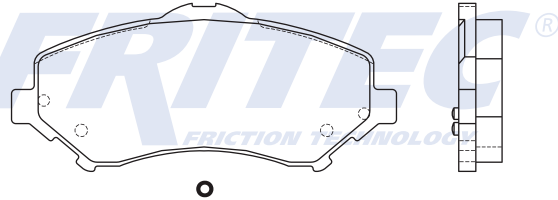

589

8390-Z D1274

D/F	T/R	E/T
X		16.0

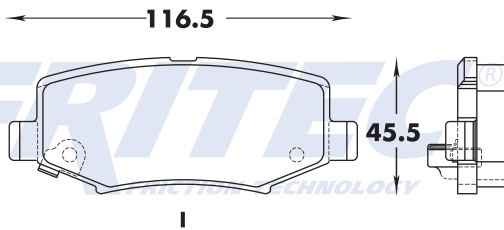

8390-Z D1274

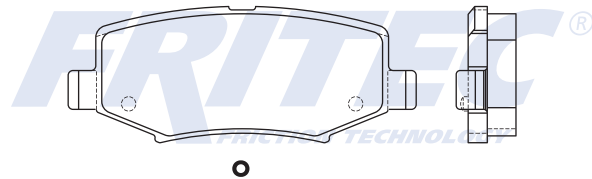

590

8391-Z D1275

D/F	T/R	E/T
X		15.0

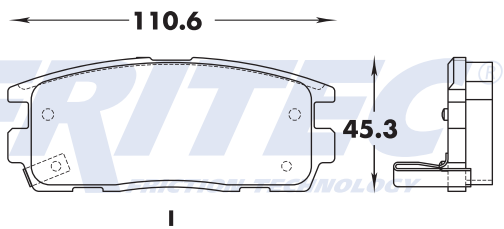

8391-Z D1275

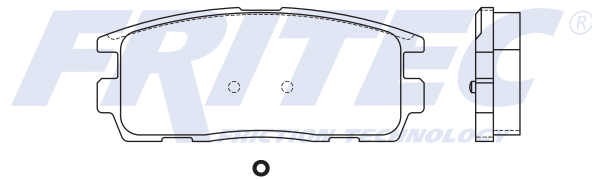

591

8392-Z D1276

D/F	T/R	E/T
X		16.3

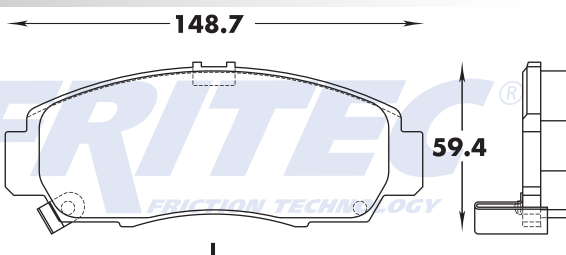

8392-Z D1276

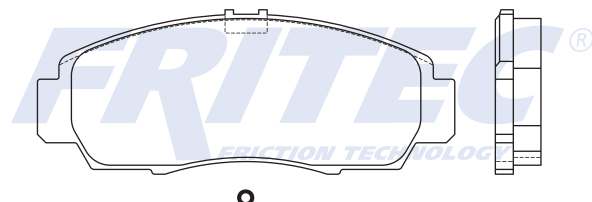

592

8393-Z D1277

D/F	T/R	E/T
X		15.8

8393-Z D1277

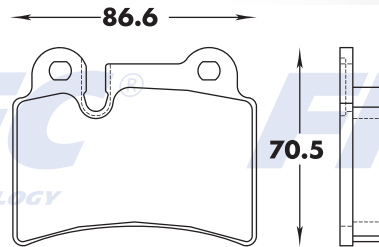

593

8394-Z D1278

D/F	T/R	E/T
X		19, 18.7

8394-Z D1278

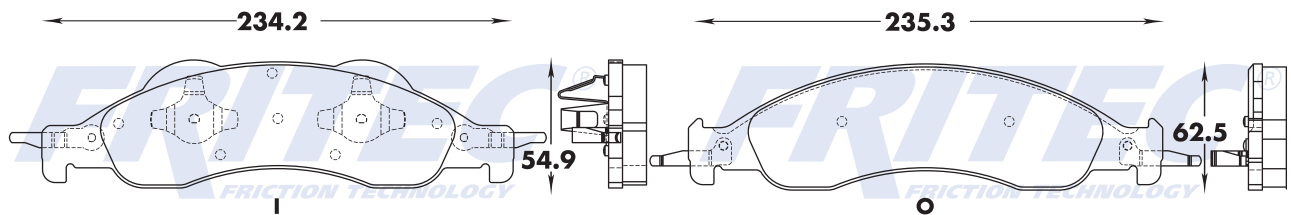

594

8395-Z D1279

D/F	T/R	E/T
X		21.0, 19.9

8395-Z D1279

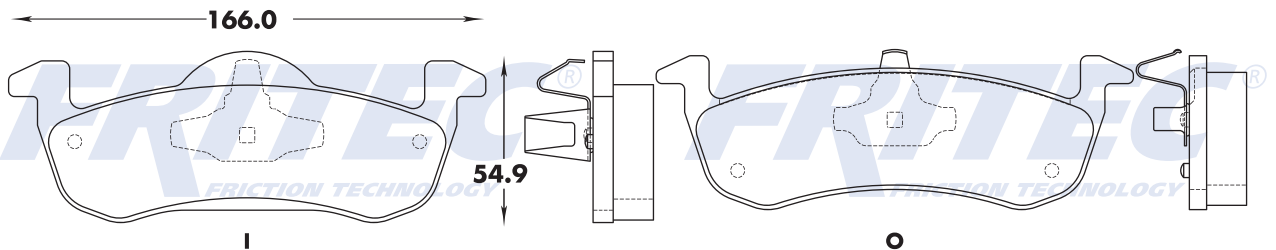

595

8396-Z D1280

D/F	T/R	E/T
X		16.9

8396-Z D1280

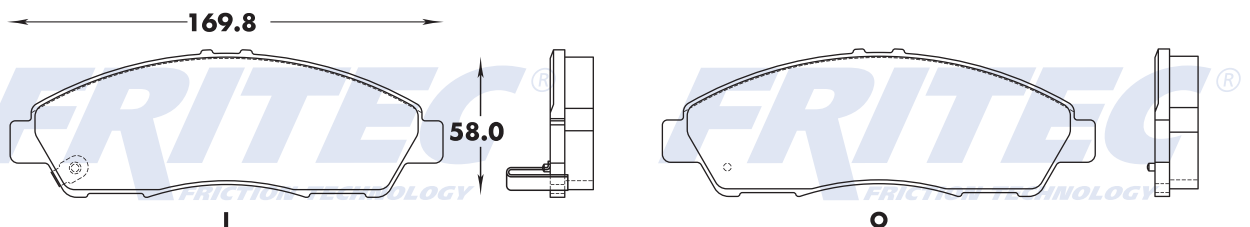

596

8397-Z D1281

D/F	T/R	E/T
X		15.4

8397-Z D1281

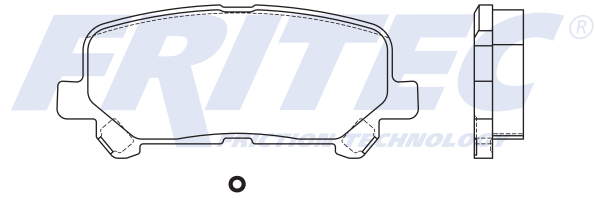
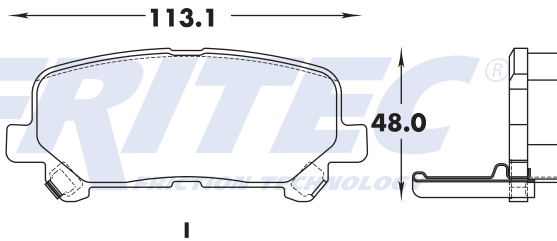

597

8403-Z D1286

D/F	T/R	E/T
X		18.0

8403-Z D1286

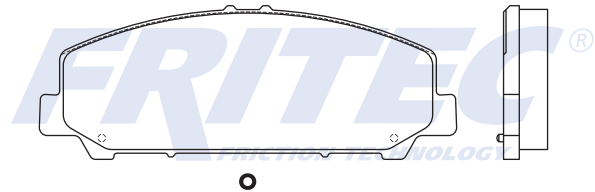
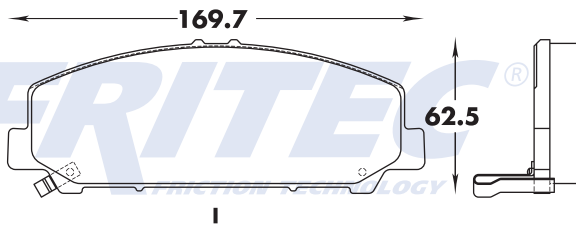

598

8403-Z1 D1509

D/F	T/R	E/T
X		18.0

8403-Z1 D1509

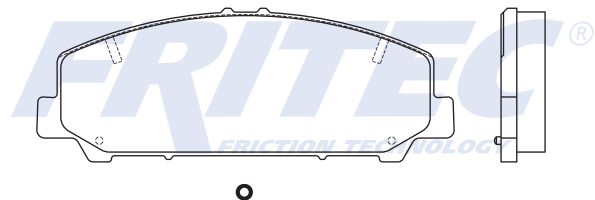
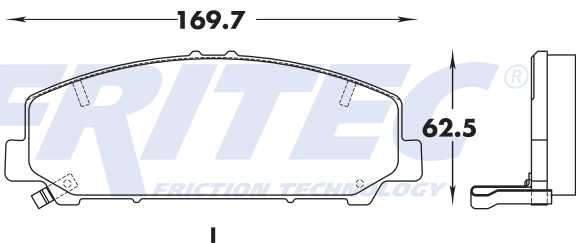

599

8405-Z D1288

D/F	T/R	E/T
X		13.8

8405-Z D1288

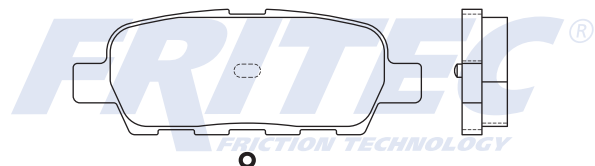
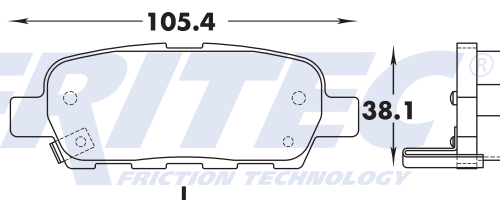

600

8410-Z D1169

D/F	T/R	E/T
X		16.0

8410-Z D1169

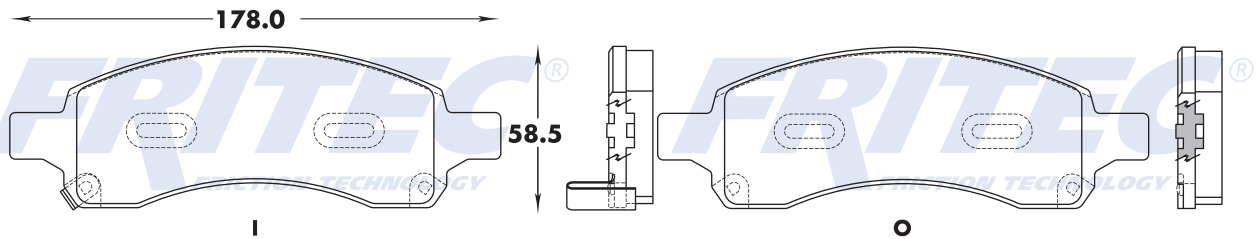

601

8411-Z D1294

D/F	T/R	E/T
X		19.0

8411-Z D1294

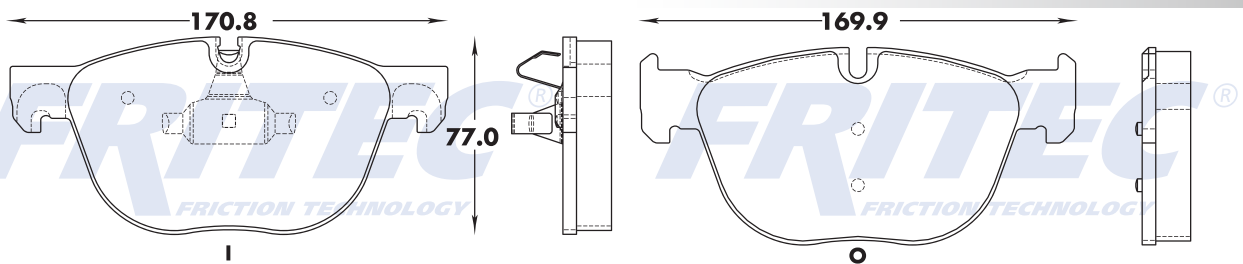

602

8419-Z D1303

D/F	T/R	E/T
X		17.9

8419-Z D1303

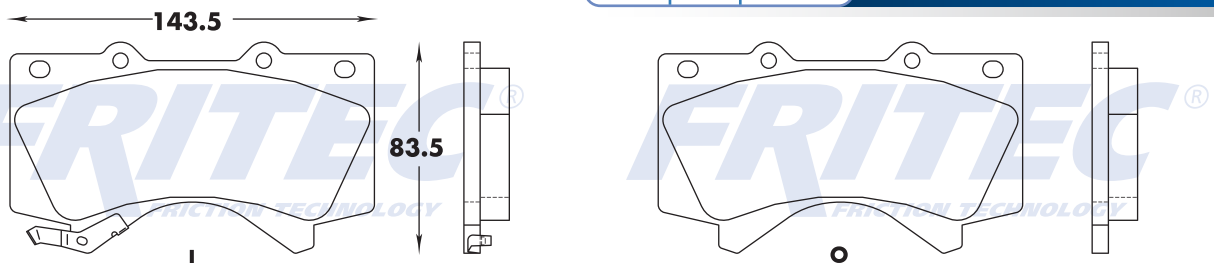

603

8420-Z D1304

D/F	T/R	E/T
X		17.3

8420-Z D1304

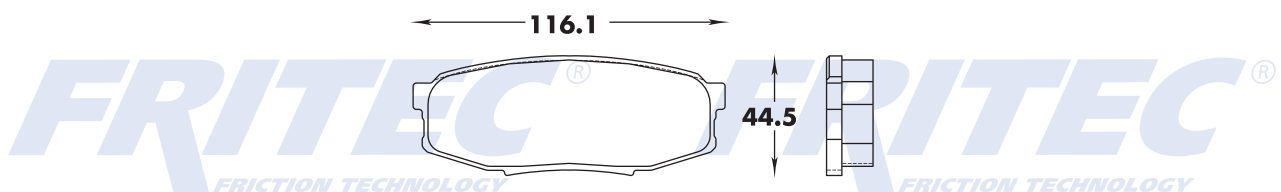

604

8421-Z D1306

D/F	T/R	E/T
X		19.0, 18.0

8421-Z D1306

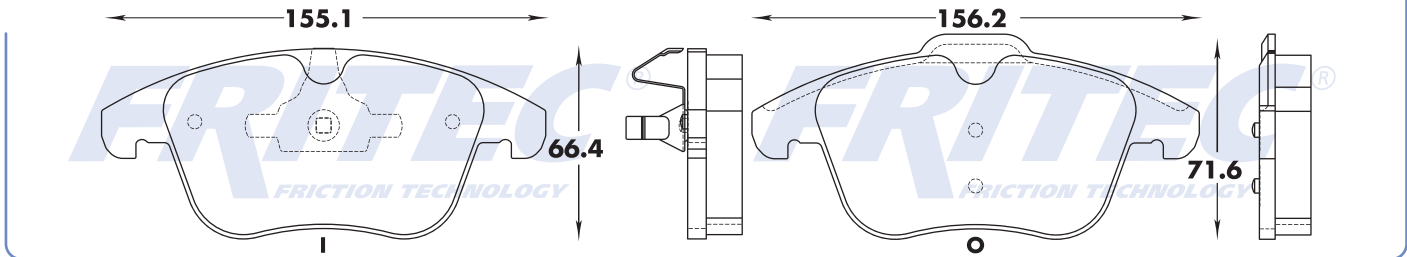

605

8422-Z D1307

D/F	T/R	E/T
X		16.0

8422-Z D1307

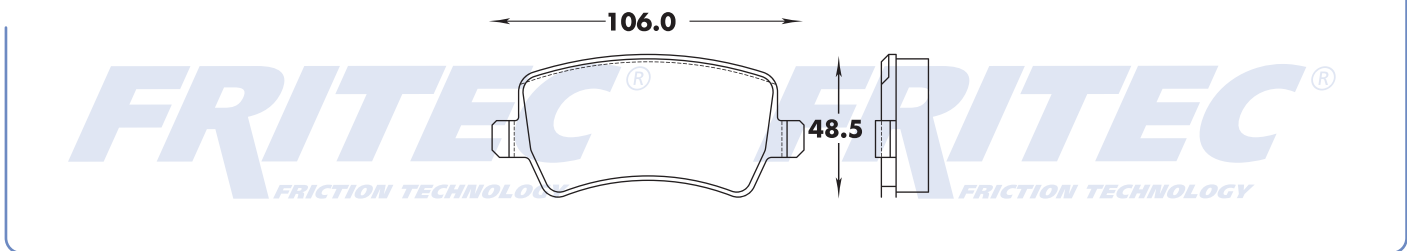

606

8423-Z D1308

D/F	T/R	E/T
X		16.9

8423-Z D1308

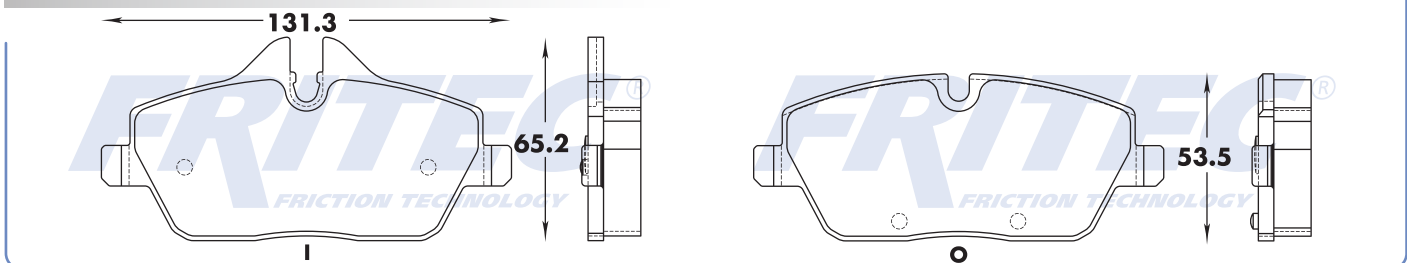

607

8424-Z D1309

D/F	T/R	E/T
X		16.2

8424-Z D1309

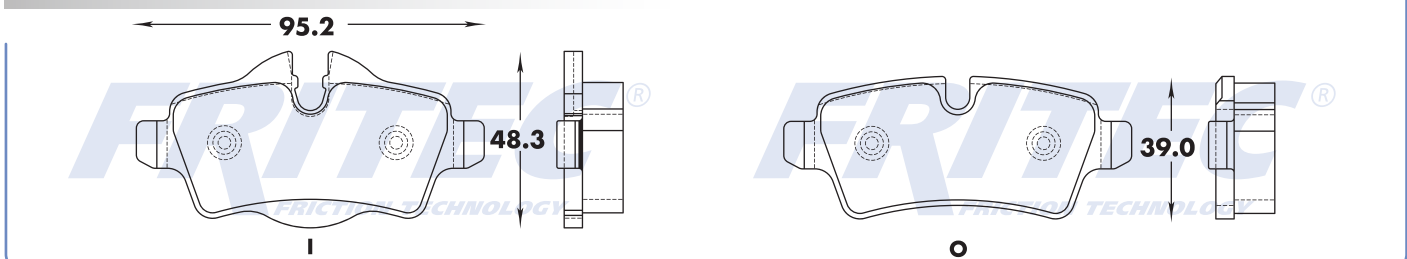

608

8428-Z D1812

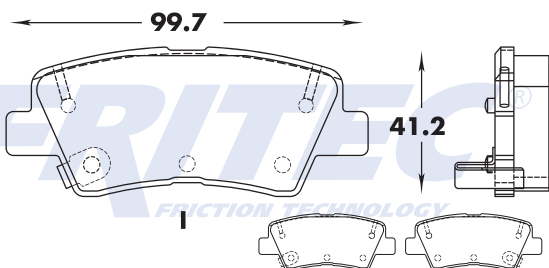

D/F	T/R	E/T
X		14.9

8428-Z D1812

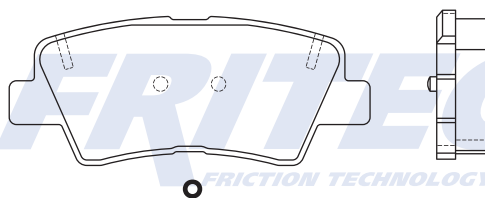

609

8428-Z D1813

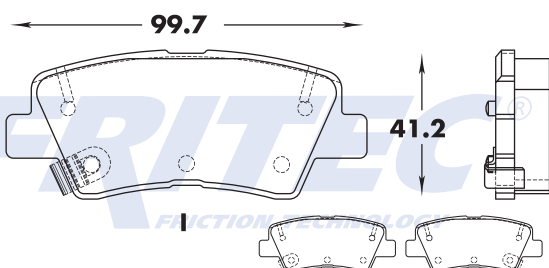

D/F	T/R	E/T
X		14.8

8428-Z D1813

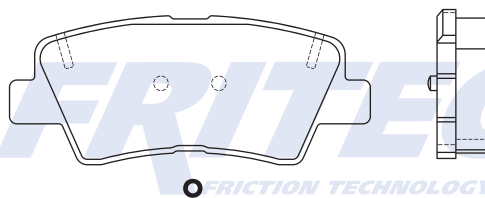

610

8430A-Z D1316

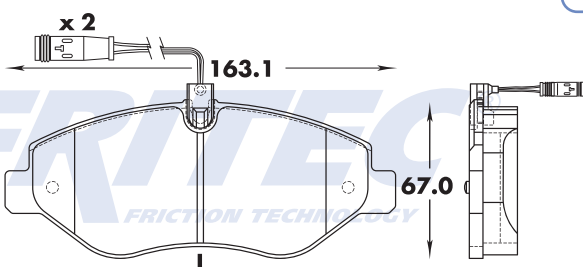

D/F	T/R	E/T
X		20.0

8430A-Z D1316

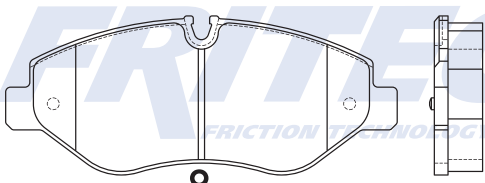

611

8431A-Z D1317

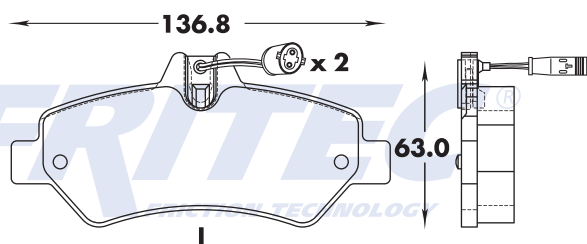

D/F	T/R	E/T
X		19.1

8431A-Z D1317

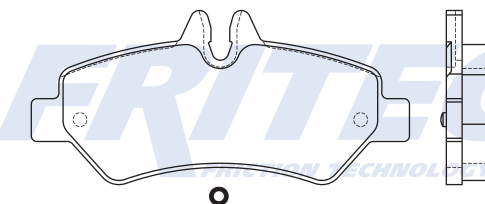

612

8434A-Z D1322

D/F	T/R	E/T
X		17.7

8434A-Z D1322

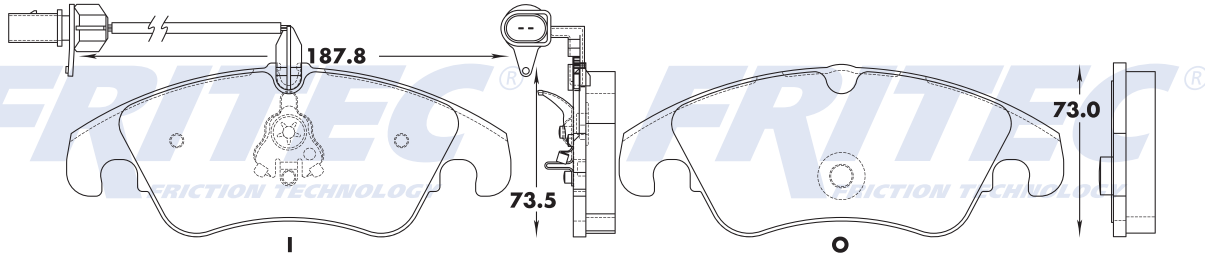

613

8436-Z D1324

D/F	T/R	E/T
X		17.5

8436-Z D1324

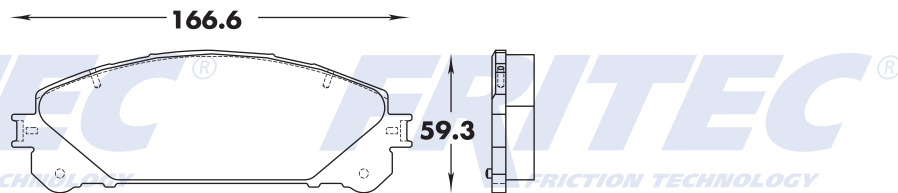

614

8437-Z D1325

D/F	T/R	E/T
X		15.4

8437-Z D1325

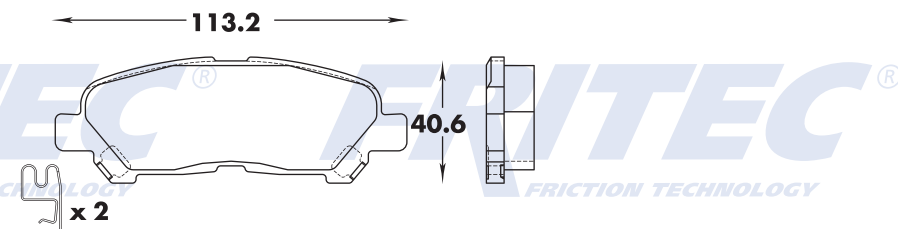

615

8438-Z D1326

D/F	T/R	E/T
X		16.8

8438-Z D1326

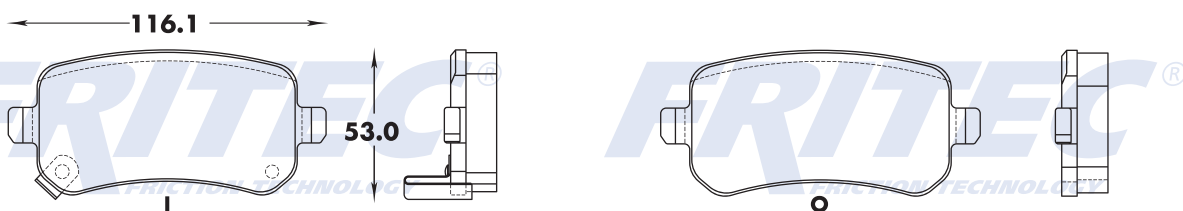

616

8440-Z D1328

D/F	T/R	E/T
X		18.7

8440-Z D1328

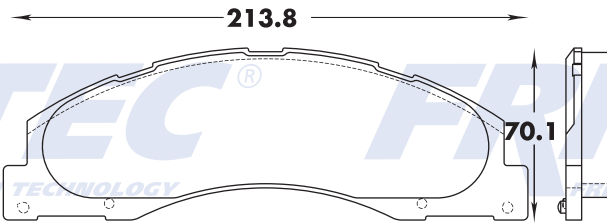

617

8441-Z D1329

D/F	T/R	E/T
X		17.0, 15.3

8441-Z D1329

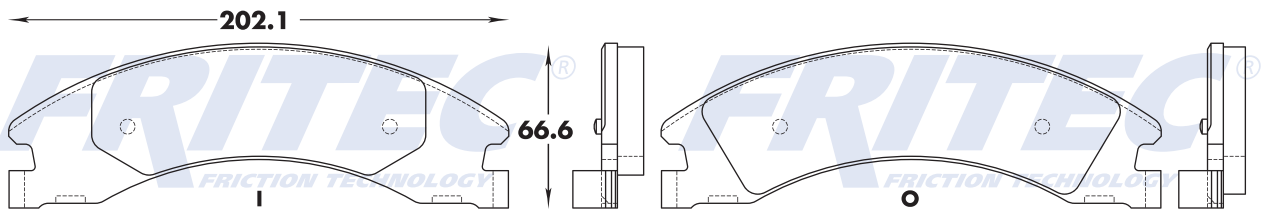

618

8442-Z D1330

D/F	T/R	E/T
X		19.5

8442-Z D1330

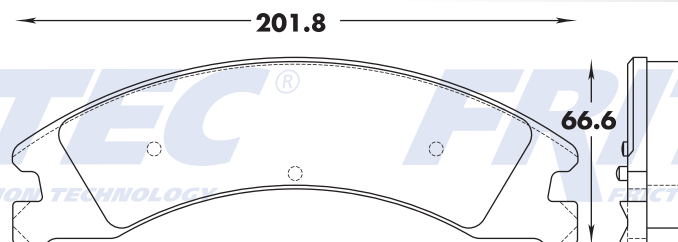

619

8445-Z D1047

D/F	T/R	E/T
X		17.0

8445-Z D1047

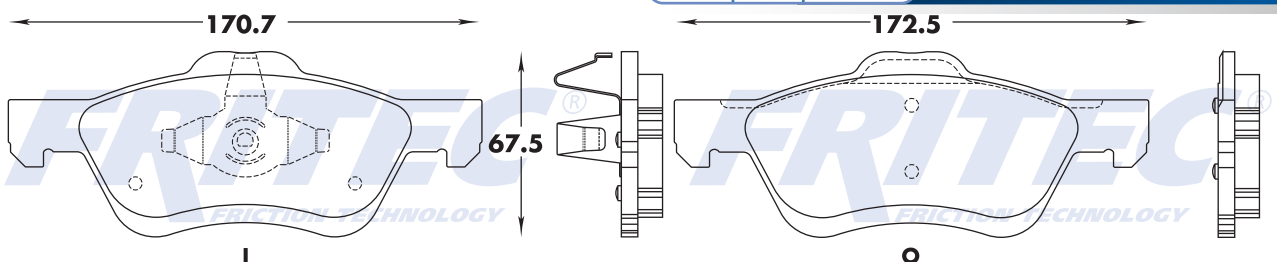

620

8446-Z D1335

D/F	T/R	E/T
X		20.0

8446-Z D1335

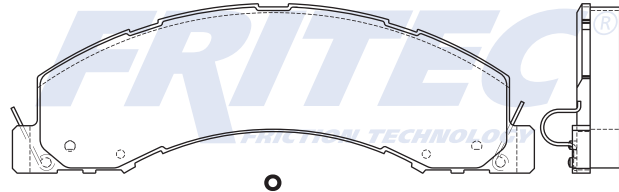
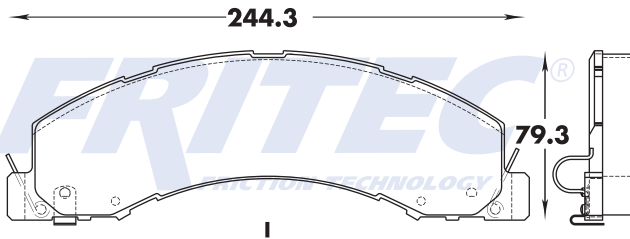

621

8447-Z D1336

D/F	T/R	E/T
X		14.7

8447-Z D1336

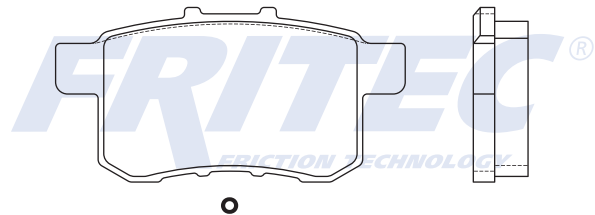
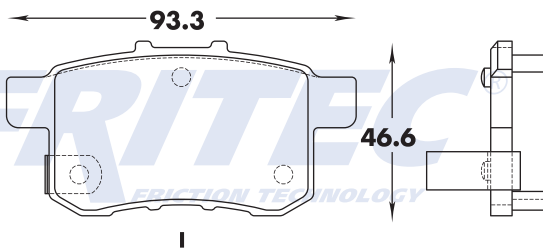

622

8449-Z1 D1374

D/F	T/R	E/T
X		16.8

8449-Z1 D1374

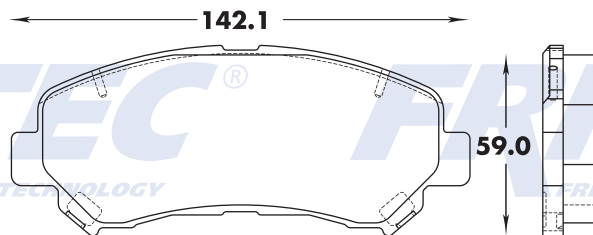

623

8449-Z D1737

D/F	T/R	E/T
X		16.8

8449-Z D1737

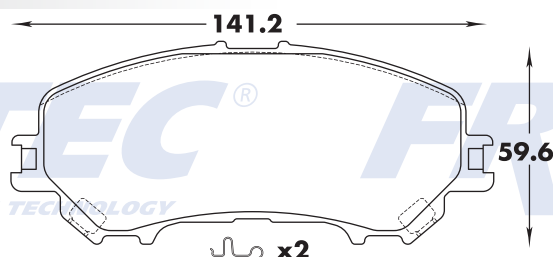

624

8450-Z D1339

D/F	T/R	E/T
X		16.8

8450-Z D1339

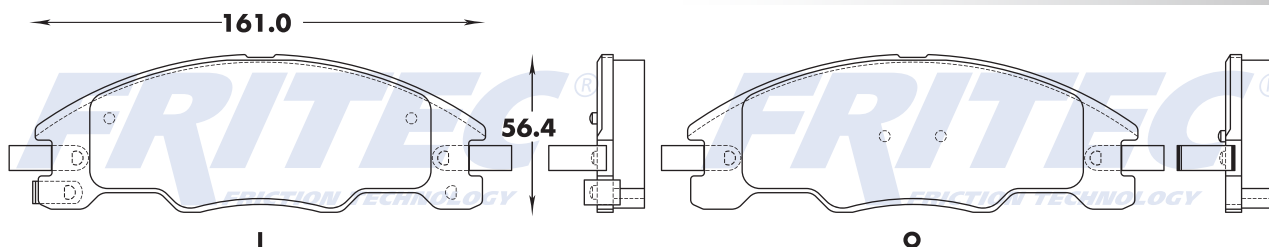

625

8451-Z D1340

D/F	T/R	E/T
X		19.5

8451-Z D1340

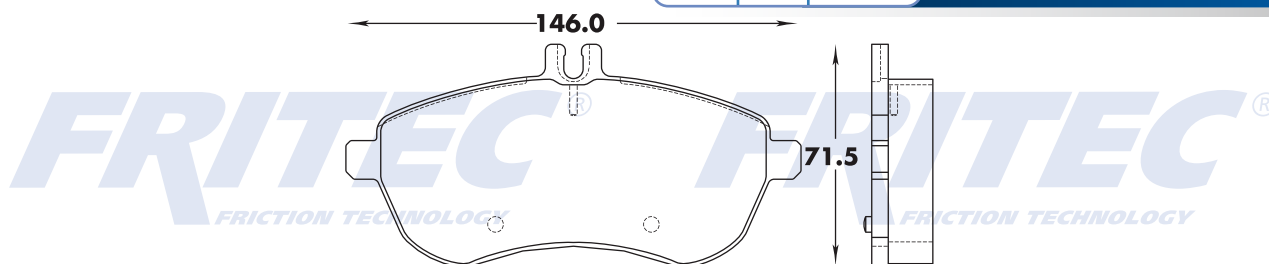

626

8452-Z D1341

D/F	T/R	E/T
X		16.9

8452-Z D1341

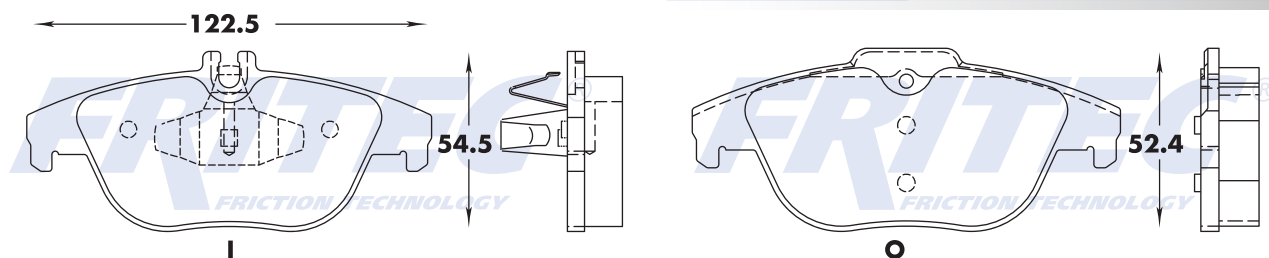

627

8453-Z D1342

D/F	T/R	E/T
X		18.4

8453-Z D1342

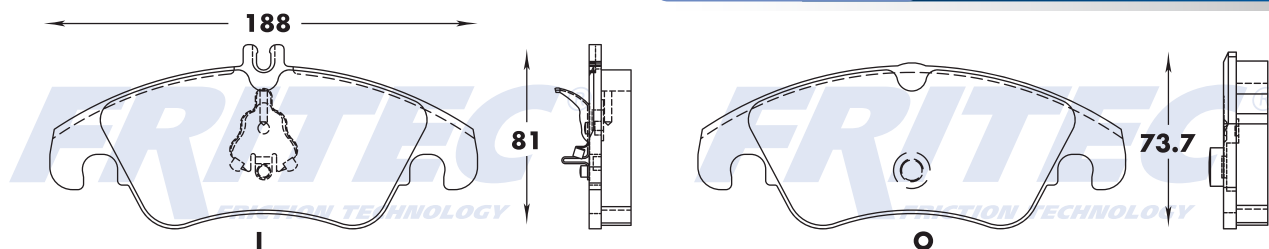

628

8454-Z D784

D/F	T/R	E/T
X		19.0

8454-Z D784

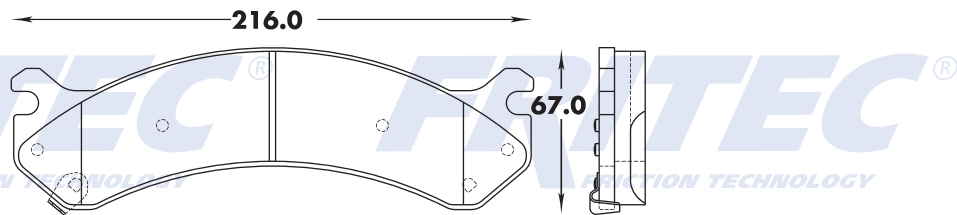

629

8463-Z1 D1423

D/F	T/R	E/T
X		14.4

8463-Z1 D1423

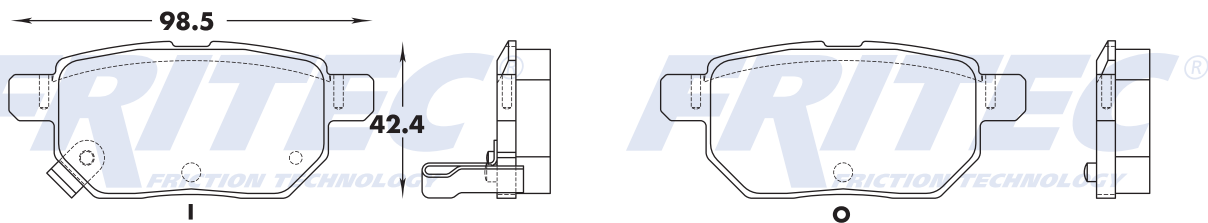

630

8466-Z D1357

D/F	T/R	E/T
X		18.8

8466-Z D1357

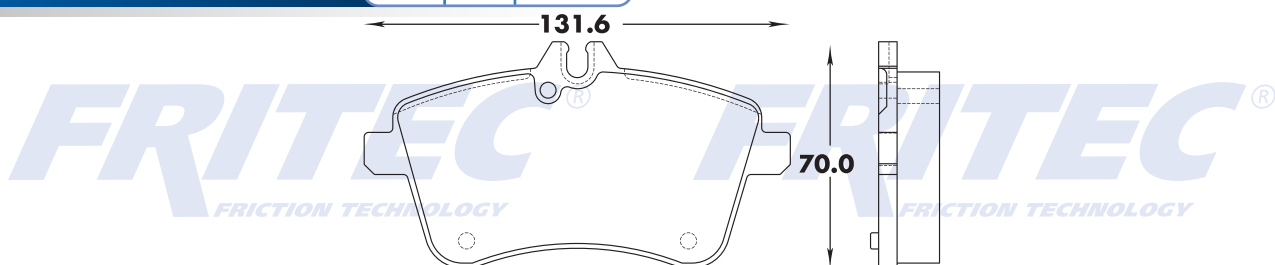

631

8468-Z D1359

D/F	T/R	E/T
X		19.3

8468-Z D1359

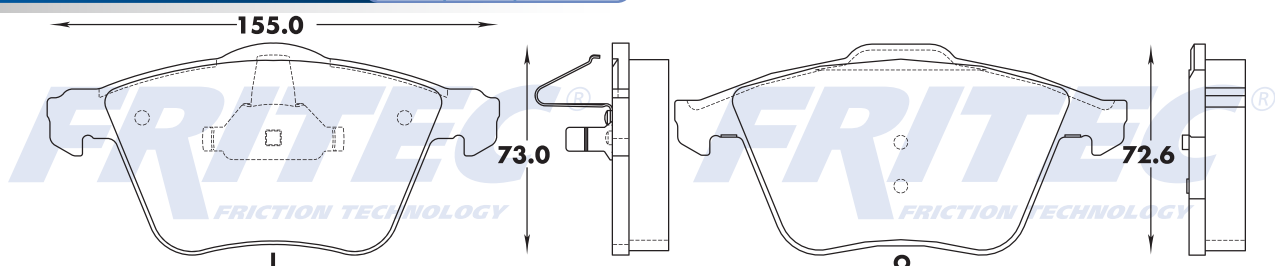

632

8470-Z D1361

D/F	T/R	E/T
X		19.2

8470-Z D1361

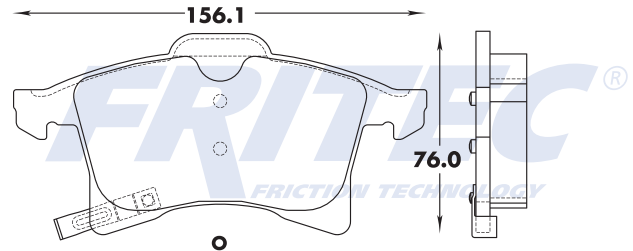
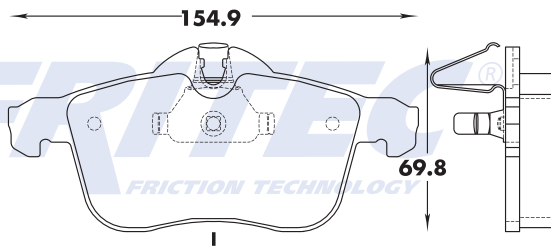

633

8472-Z D1363

D/F	T/R	E/T
X		18.0

8472-Z D1363

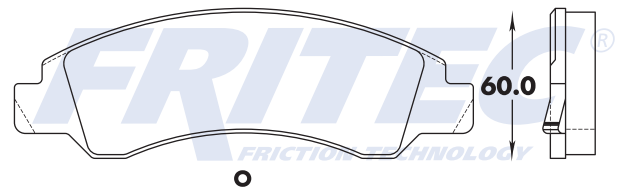
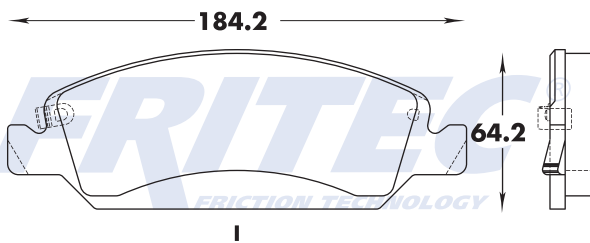

634

8477-Z D1368

D/F	T/R	E/T
X		13.5

8477-Z D1368

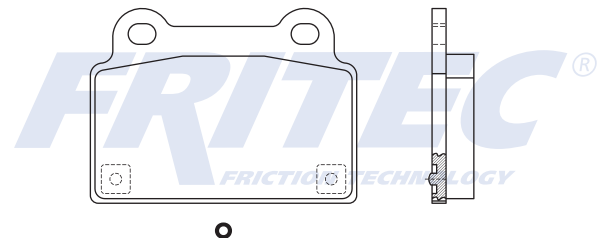
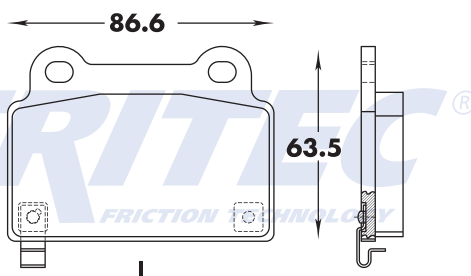

635

8481-Z D1327

D/F	T/R	E/T
X		17.5

8481-Z D1327

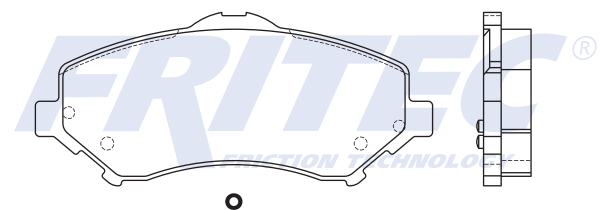
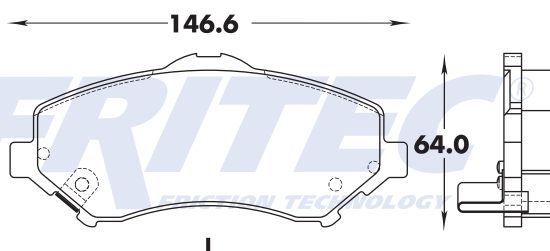

636

8483-Z D1371

D/F	T/R	E/T
X		15.9

8483-Z D1371

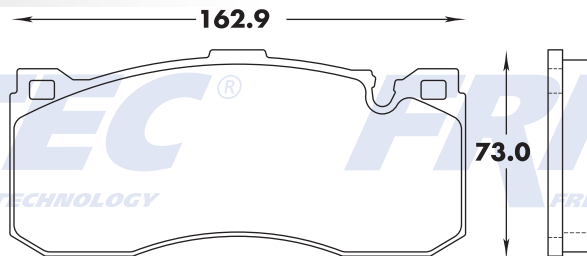

637

8484-Z D1372

D/F	T/R	E/T
X		15.2

8484-Z D1372

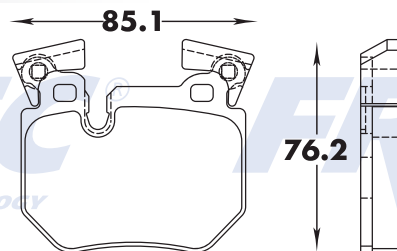

638

8486A-Z D1375

D/F	T/R	E/T
X		18.8

8486A-Z D1375

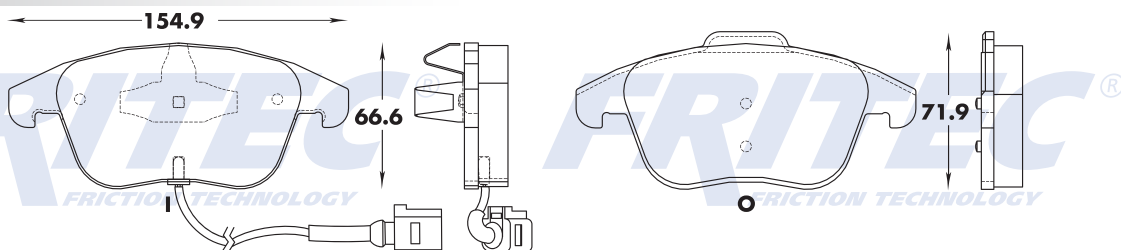

639

8488-Z D1377

D/F	T/R	E/T
X		16.8

8488-Z D1377

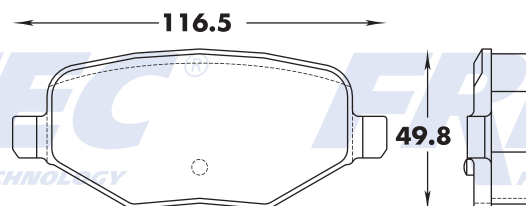

640

8489-Z D1379

D/F	T/R	E/T
X		14.3

8489-Z D1379

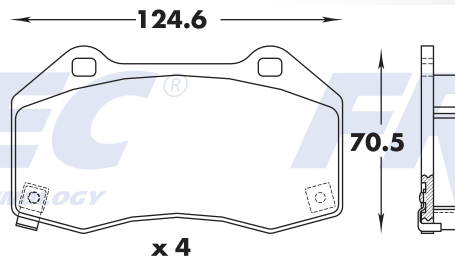

641

8494-Z D1386

D/F	T/R	E/T
X		16.8

8494-Z D1386

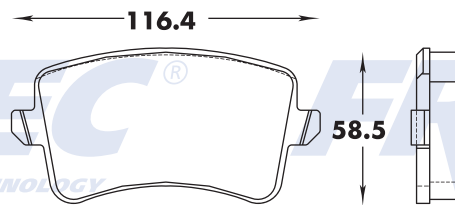

642

84X0-Z F368

D/F	T/R	E/T
X		17.9

84X0-Z F368

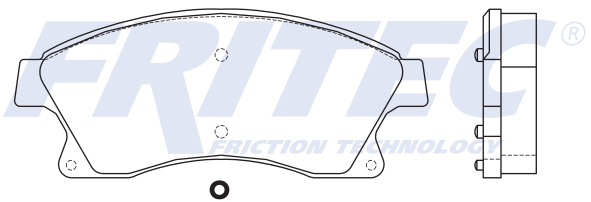
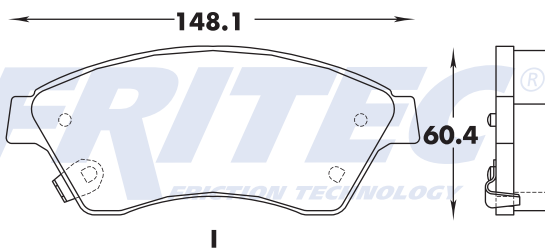

643

84X6-Z D1468

D/F	T/R	E/T
X		16.3

84X6-Z D1468

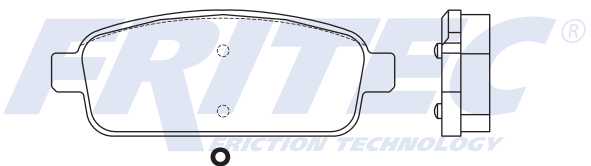
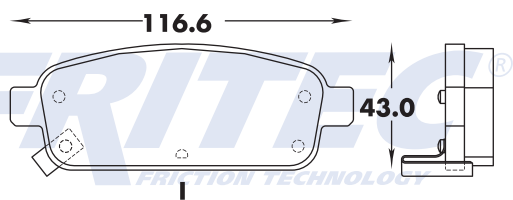

644

84X6-Z F370

D/F	T/R	E/T
X		16.3

84X6-Z F370

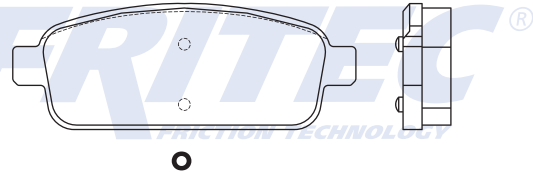
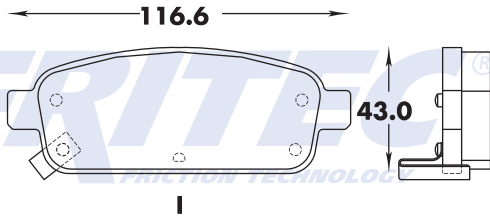

645

84X8-Z F387

D/F	T/R	E/T
X		14.8

84X8-Z F387

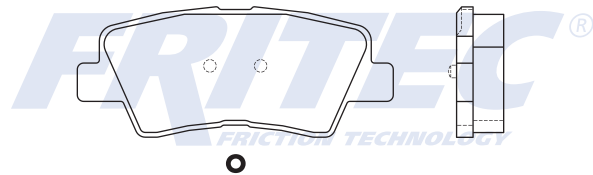
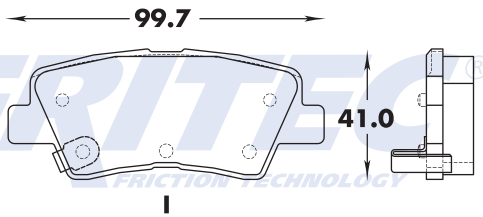

646

8776-Z D1567

D/F	T/R	E/T
X		17.0

8776-Z D1567

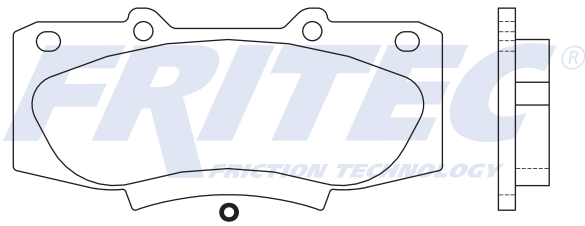
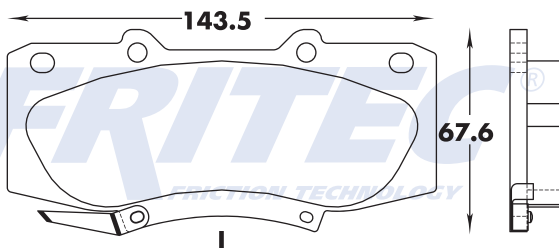

647

8500-Z D1391

D/F	T/R	E/T
X		15.2

8500-Z D1391

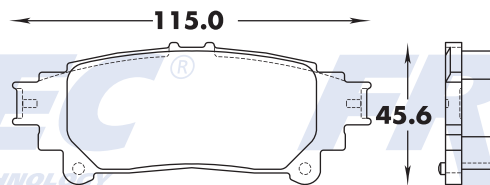

648

8502-Z D1394

D/F	T/R	E/T
X		15.9

8502-Z D1394

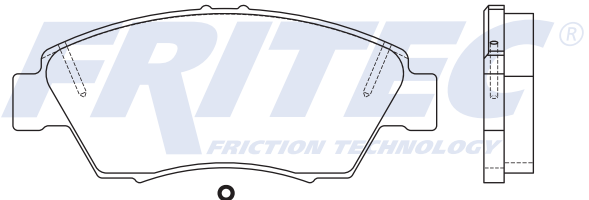
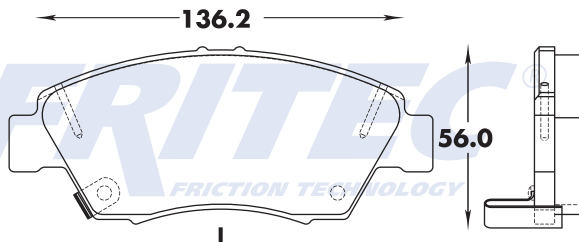

649

8507-Z D1399

D/F	T/R	E/T
X		20.0

8507-Z D1399

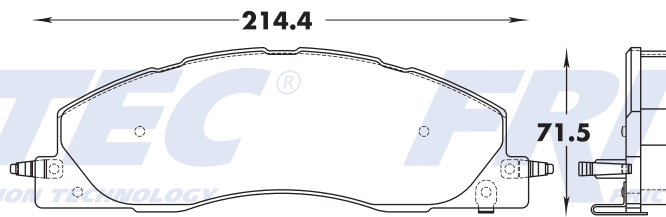

650

8508-Z D1400

D/F	T/R	E/T
X		19.0

8508-Z D1400

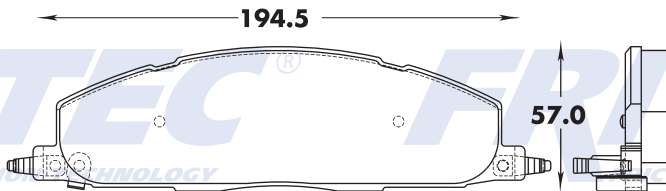

651

8512-Z D1404

D/F	T/R	E/T
X		17.8

8512-Z D1404

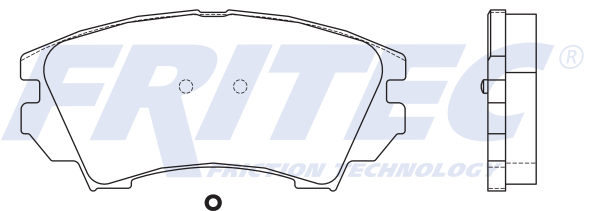
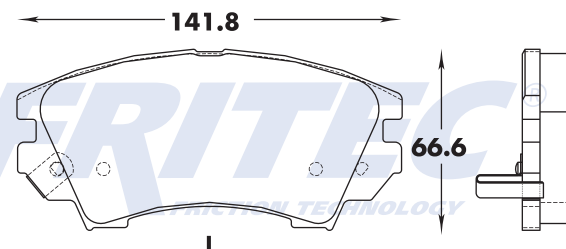

652

8513-Z D1405

D/F	T/R	E/T
X		15.4

8513-Z D1405

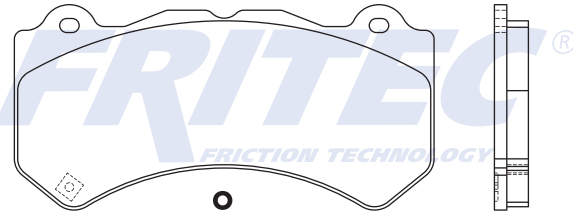
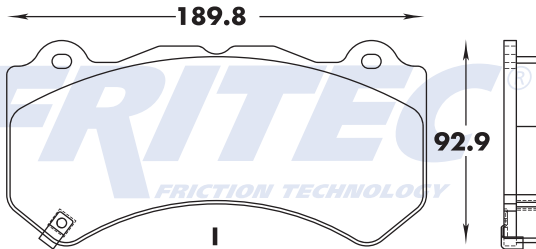

653

8523-Z D1411

D/F	T/R	E/T
X		19.7

8523-Z D1411

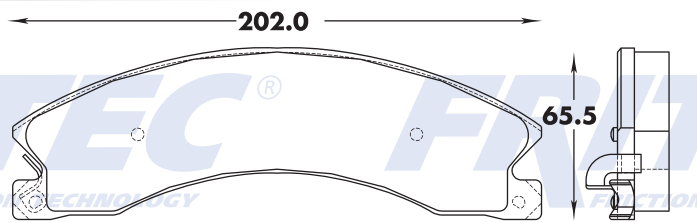

654

8525-Z D1412

D/F	T/R	E/T
X		19.0, 18.5

8525-Z D1412

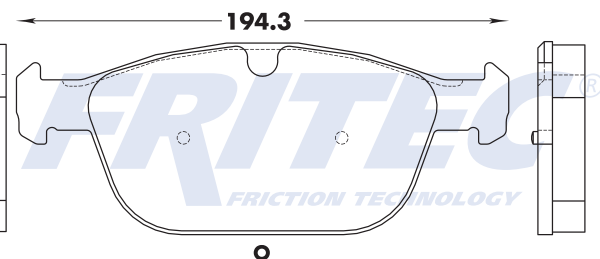
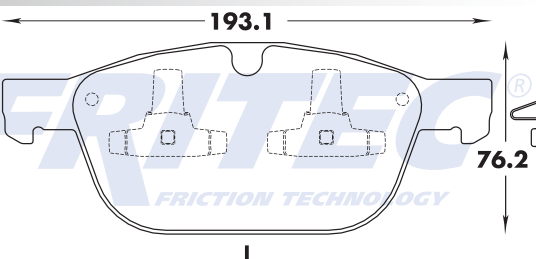

655

8528-Z D1414

D/F	T/R	E/T
X		18.2

8528-Z D1414

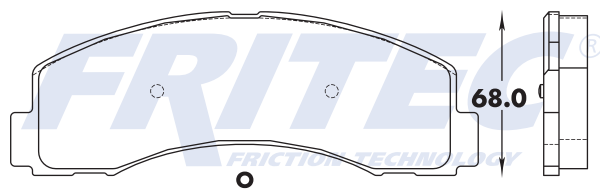
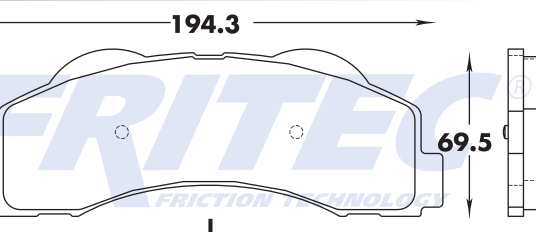

656

8536-Z D1421

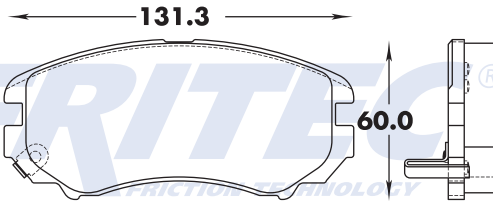

I

D/F	T/R	E/T
X		18.0

8536-Z D1421

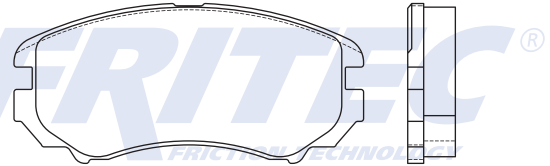

O

657

8538-Z D1184

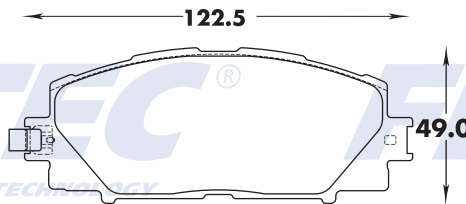

I

D/F	T/R	E/T
X		15.6

8538-Z D1184



O

658

8547-Z D1430

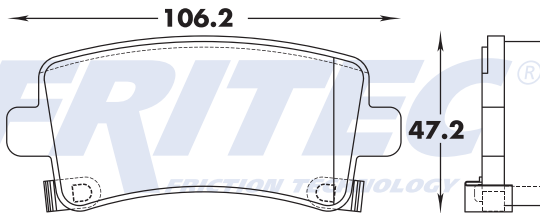

I

D/F	T/R	E/T
X		16.5

8547-Z D1430

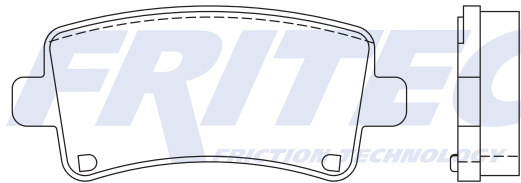

O

659

8550-Z D1433

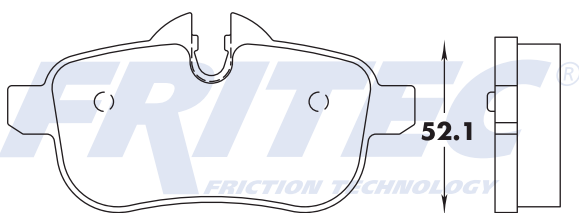

I

D/F	T/R	E/T
X		17

8550-Z D1433

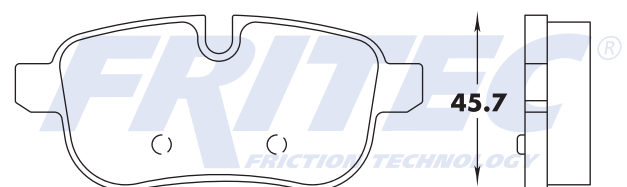

O

660

8555-Z D1437

D/F	T/R	E/T
X		17.7

8555-Z D1437

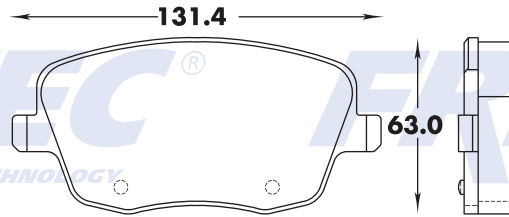

661

8575-Z D1439

D/F	T/R	E/T
X		14.9

8575-Z D1439

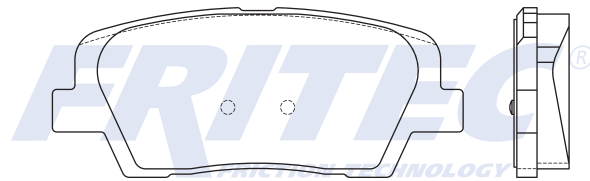
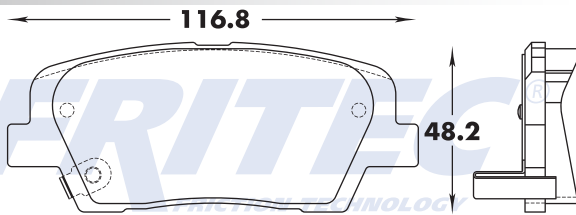

662

8614-Z D1295

D/F	T/R	E/T
X		16.9

8614-Z D1295

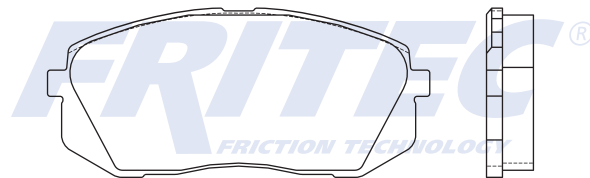
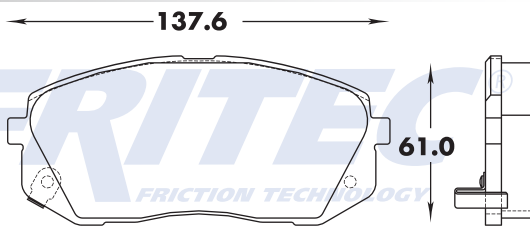

663

8615-Z D1447

D/F	T/R	E/T
X		16.9

8615-Z D1447

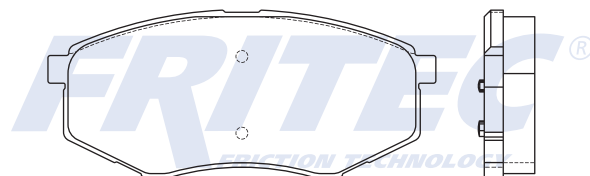
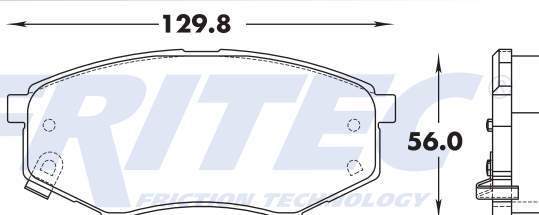

664

8536-Z D1421

D/F	T/R	E/T
X		18.0

8536-Z D1421

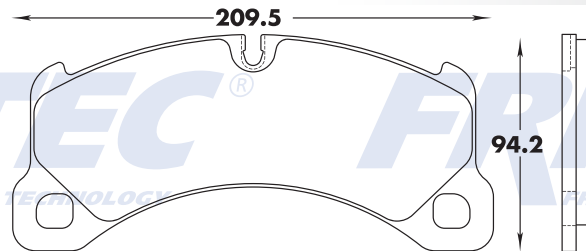

665

8643-Z D1453

D/F	T/R	E/T
X		16.1

8643-Z D1453

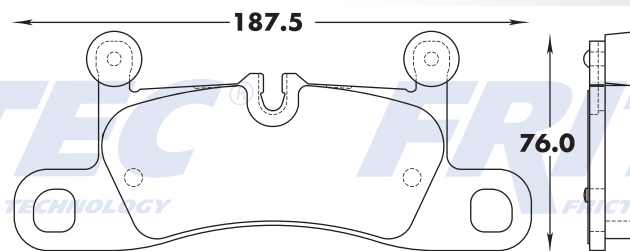

666

8652-Z D1334

D/F	T/R	E/T
X		14.4

8652-Z D1334

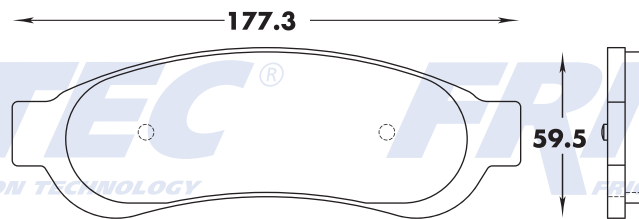

667

8653-Z D1454

D/F	T/R	E/T
X		16.4

8653-Z D1454

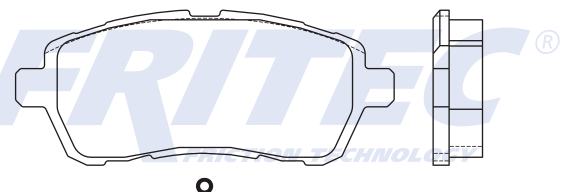
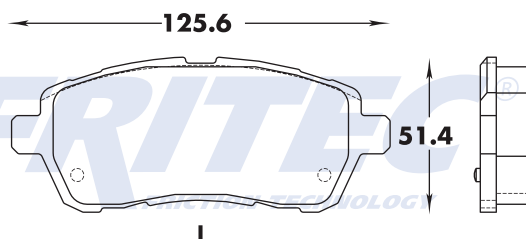

668

8655-Z D1455

D/F	T/R	E/T
X		18.5

8655-Z D1455

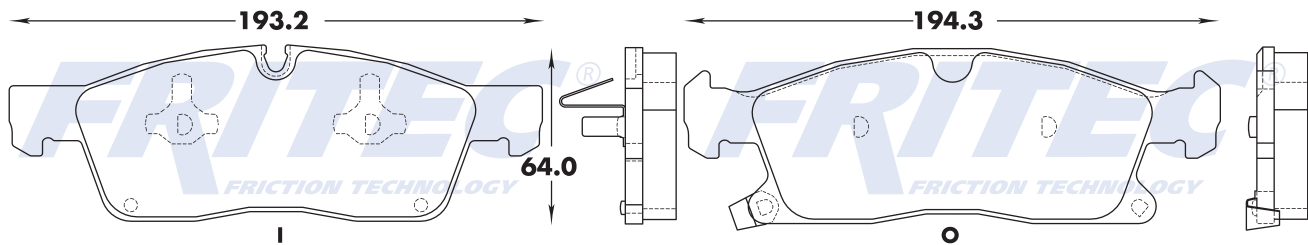

669

8656-Z D1456

D/F	T/R	E/T
X		15.5

8656-Z D1456

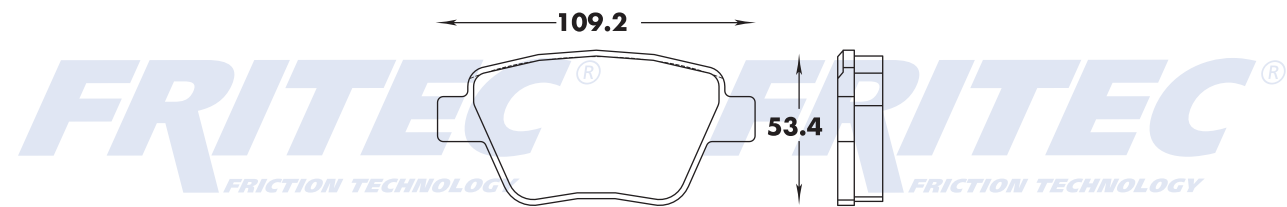

670

8667-Z D1467

D/F	T/R	E/T
X		14.0

8667-Z D1467

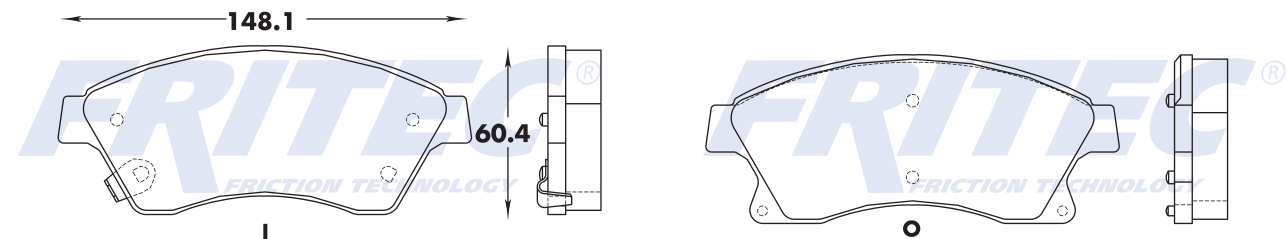

671

8672-Z D1473

D/F	T/R	E/T
X		17.1

8672-Z D1473

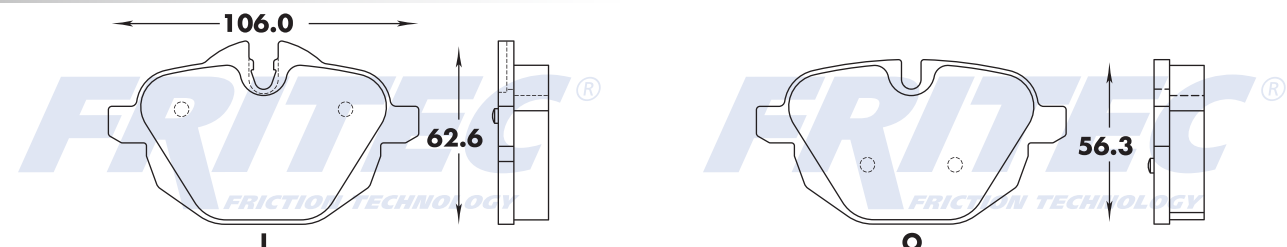

672

8698-Z D1498

D/F	T/R	E/T
X		16.8

8698-Z D1498

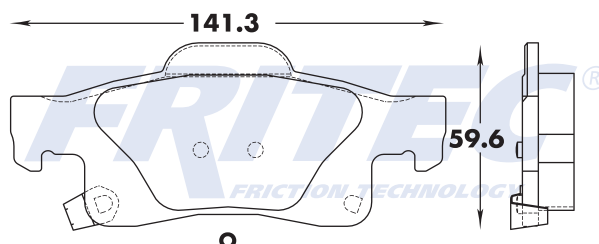
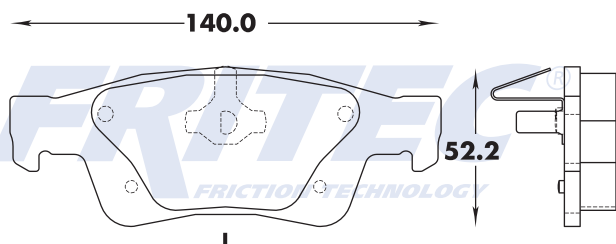

673

8922-Z D1696

D/F	T/R	E/T
X		16.9

8922-Z D1696

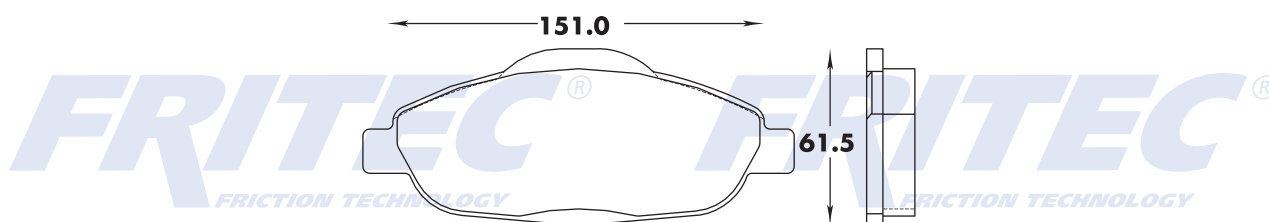

674

86X4-Z F376

D/F	T/R	E/T
X		17.5

86X4-Z F376

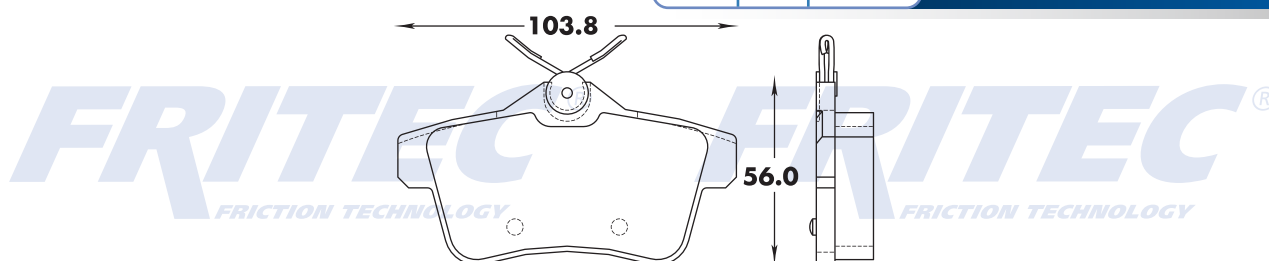

675

8703-Z D1327

D/F	T/R	E/T
X		17.1

8703-Z D1327

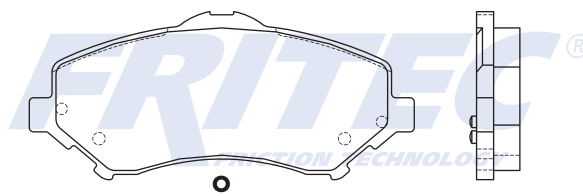
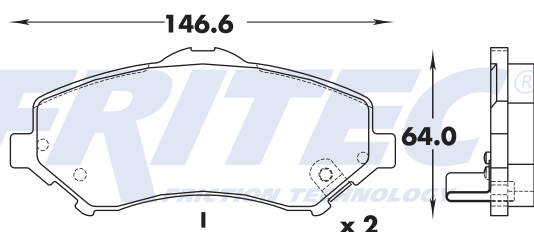

676

8711-Z D1451

D/F	T/R	E/T
X		15.1

8711-Z D1451

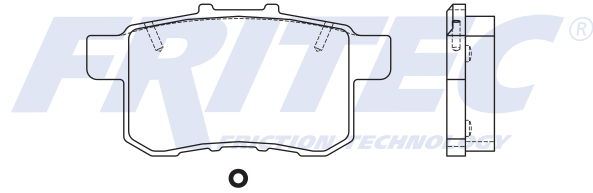
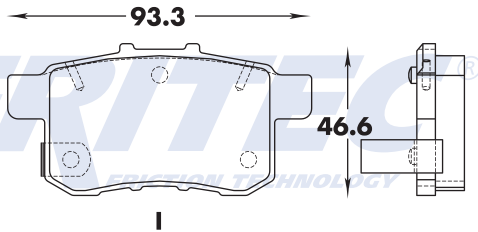

677

8715-Z D1508

D/F	T/R	E/T
X		17.9

8715-Z D1508

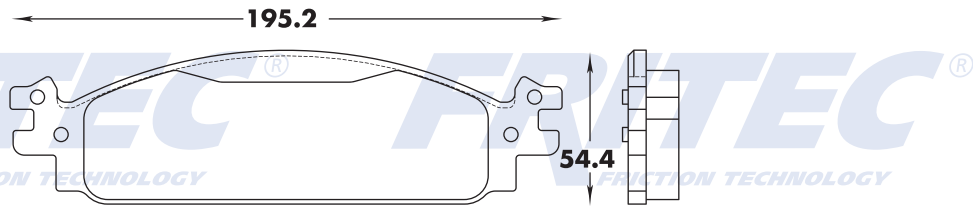

678

8731-Z D1523

D/F	T/R	E/T
X		15.7

8731-Z D1523

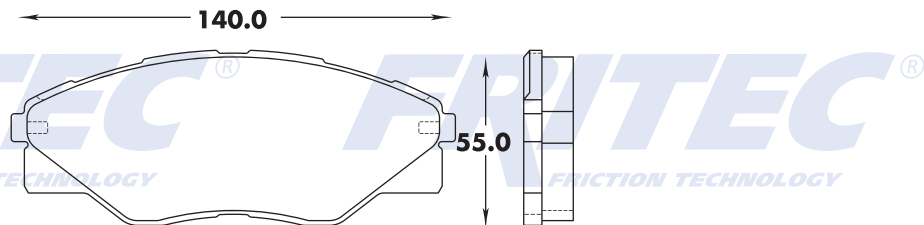

679

8738-Z D1454

D/F	T/R	E/T
X		14.5

8738-Z D1454

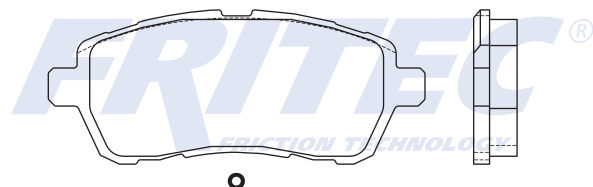
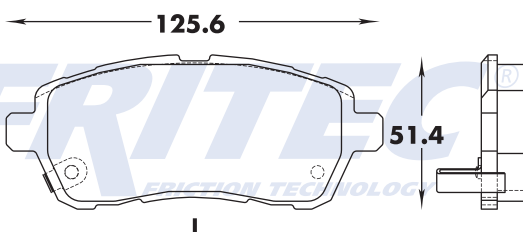

680

8760-Z D1107

D/F	T/R	E/T
X		19.7

8760-Z D1107

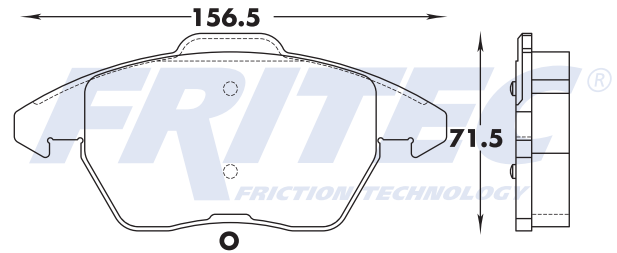
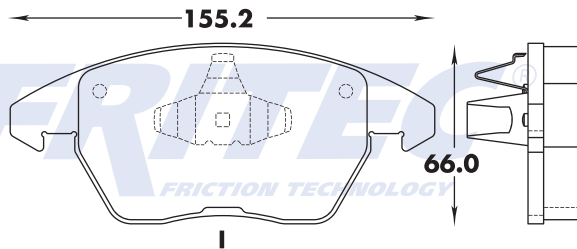

681

8767-Z D1555

D/F	T/R	E/T
X		18.0

8767-Z D1555

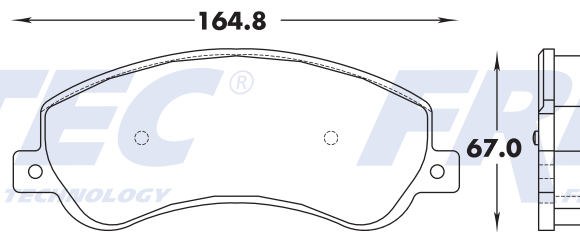

682

8768-Z D1556

D/F	T/R	E/T
X		15.9

8768-Z D1556

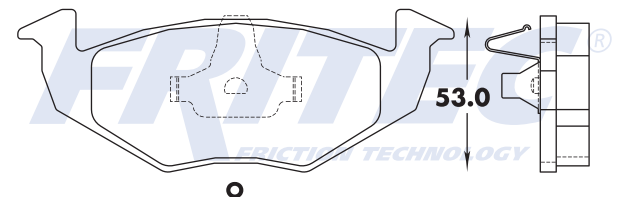
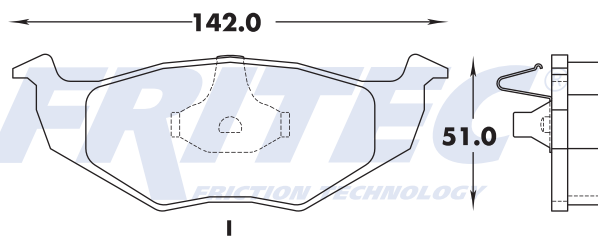

683

8772-Z D1561

D/F	T/R	E/T
X		18.2

8772-Z D1561

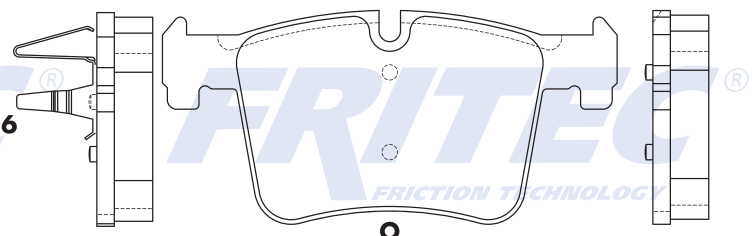
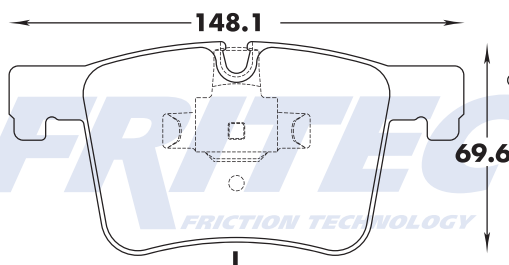

684

8777-Z D1568

D/F	T/R	E/T
X		16.0

8777-Z D1568

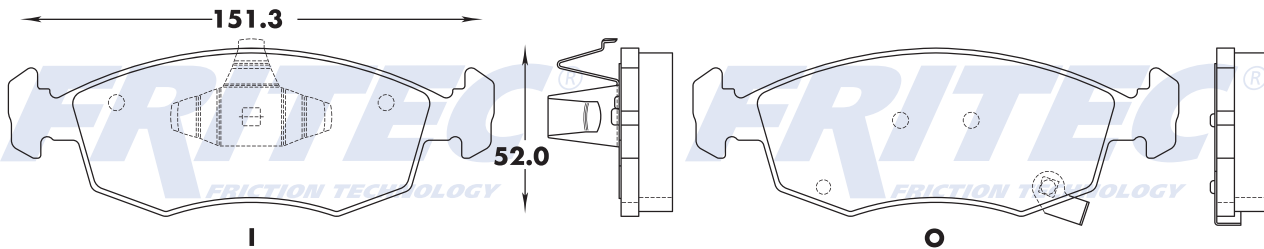

685

8778-Z D1569

D/F	T/R	E/T
X		13.9

8778-Z D1569

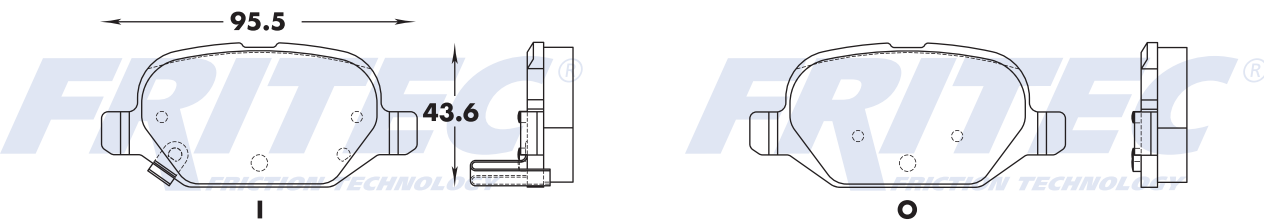

686

8800-Z D1589

D/F	T/R	E/T
X		18.0

8800-Z D1589

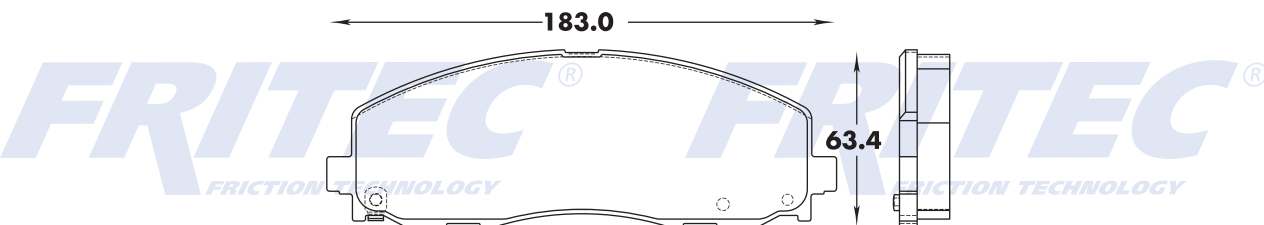

687

8801-Z D1590

D/F	T/R	E/T
X		16.9

8801-Z D1590

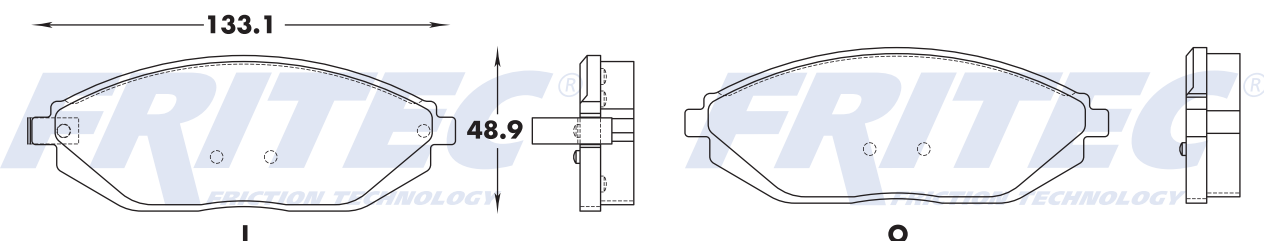

688

8807-Z D1259

D/F	T/R	E/T
X		15.9

8807-Z D1259

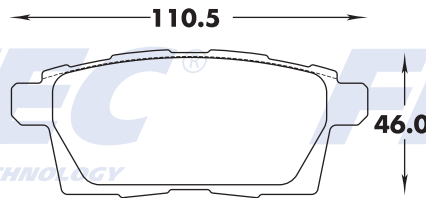

689

8810-Z D1595

D/F	T/R	E/T
X		16.9

8810-Z D1595

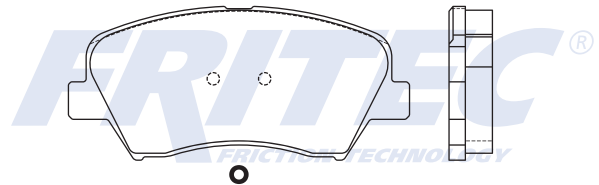
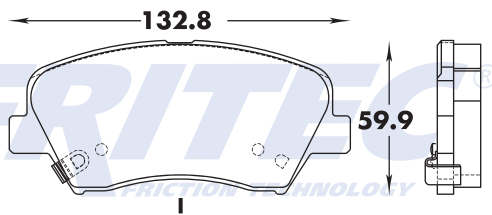

690

8811-Z D1596

D/F	T/R	E/T
X		16.6

8811-Z D1596

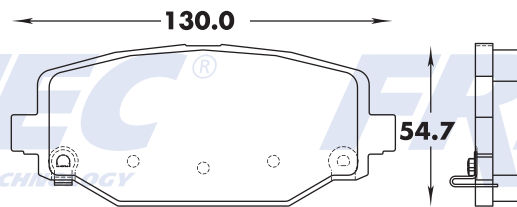

691

8816-Z D1602

D/F	T/R	E/T
X		16.6

8816-Z D1602

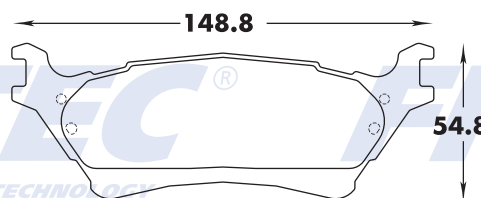

692

8822-Z1 D1609

D/F	T/R	E/T
X		16.9

8822-Z1 D1609

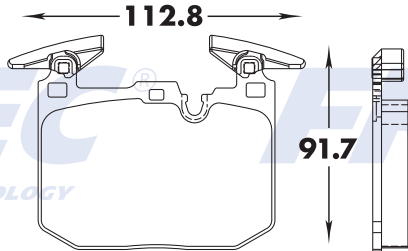

693

8822-Z D1880

T/R	E/T
X	16.9

8822-Z D1880

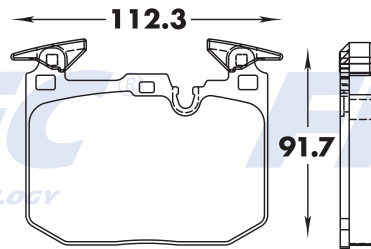

694

8823-Z D1610

D/F	T/R	E/T
X		16.3

8823-Z D1610

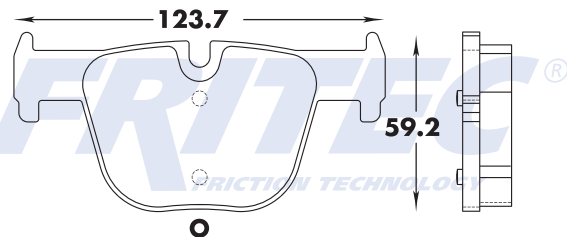
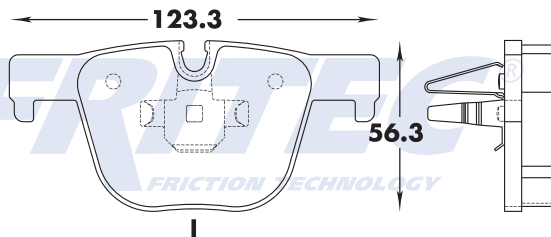

695

8825-Z D1612

D/F	T/R	E/T
X		16.7

8825-Z D1612

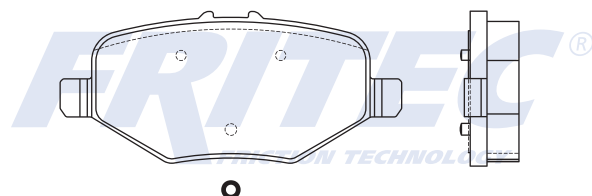
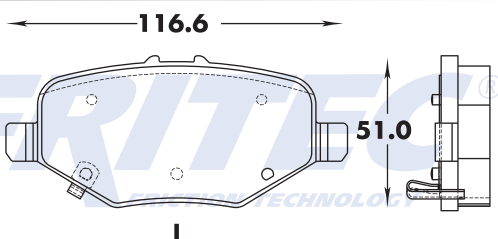

696

8826-Z D1613

D/F	T/R	E/T
X		16.5

8826-Z D1613

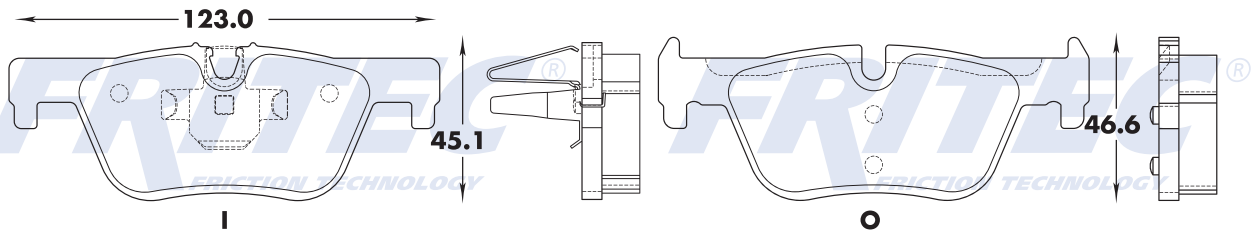

697

8836-Z D1623

D/F	T/R	E/T
X		15.7

8836-Z D1623

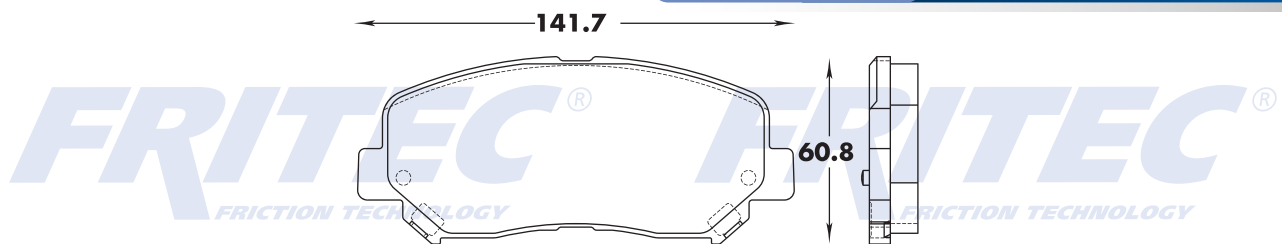

698

8837-Z D1624

D/F	T/R	E/T
X		14.3

8837-Z D1624

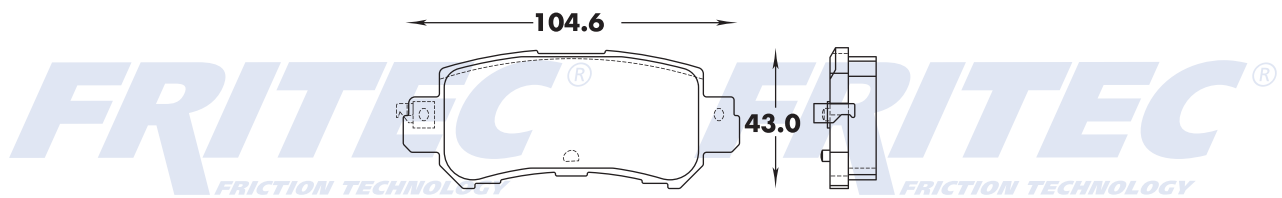

699

8840-Z D1832

D/F	T/R	E/T
X		16.9

8840-Z D1832

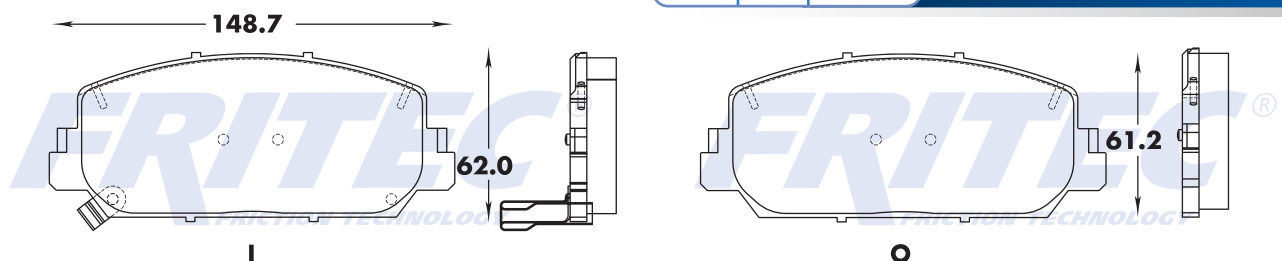

700

8840-Z D2036

D/F	T/R	E/T
X		16.9

8840-Z D2036

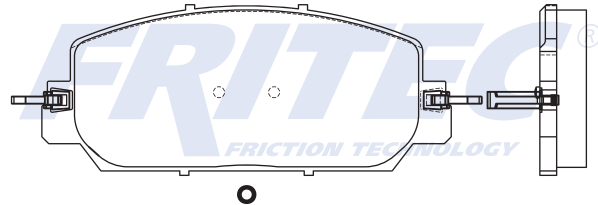
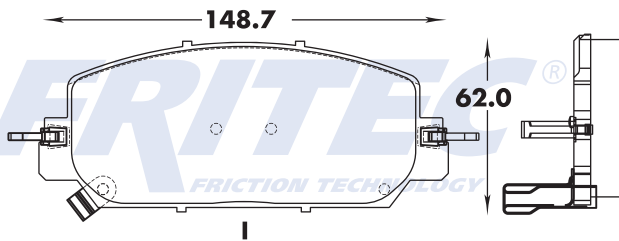

701

8844-Z D1627

D/F	T/R	E/T
X		17.3

8844-Z D1627

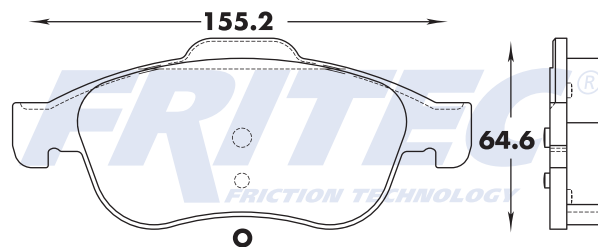
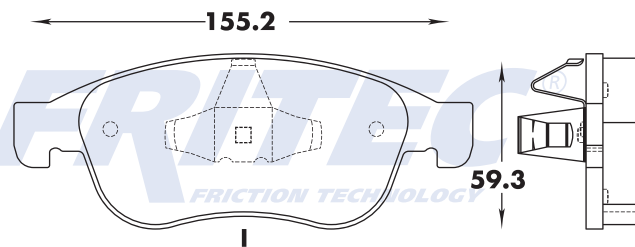

702

8867-Z D1640

D/F	T/R	E/T
X		17.8

8867-Z D1640

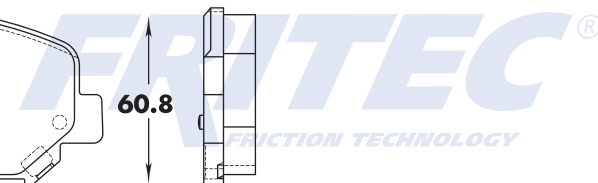
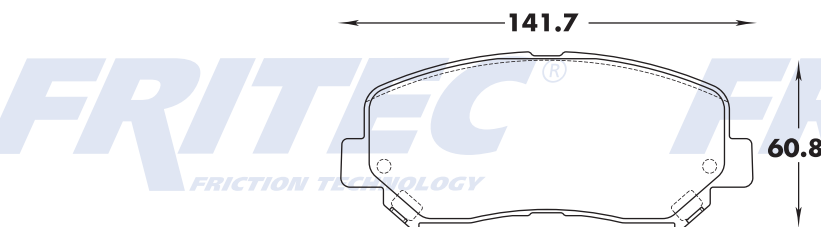

703

8868-Z D1641

D/F	T/R	E/T
X		16.0

8868-Z D1641

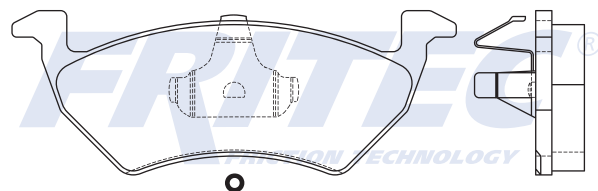
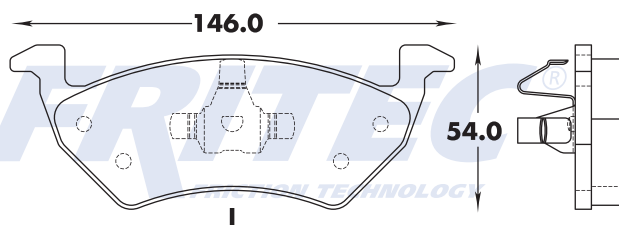

704

8873-Z D1645

D/F	T/R	E/T
X		17.9

8873-Z D1645

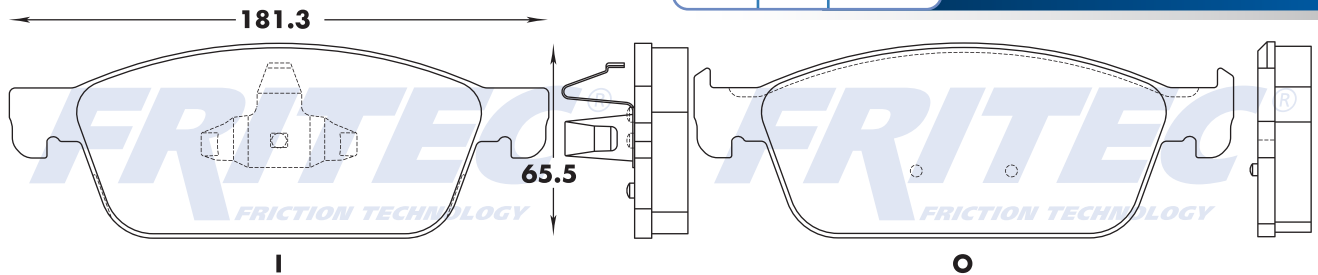

705

8875-Z D1647

D/F	T/R	E/T
X		15.5

8875-Z D1647

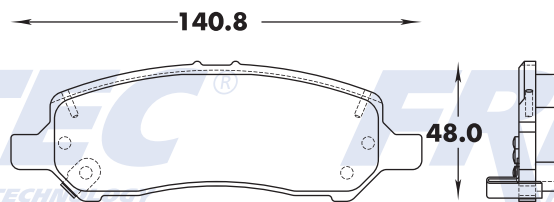

706

8877-Z D1649

D/F	T/R	E/T
X		15.8

8877-Z D1649

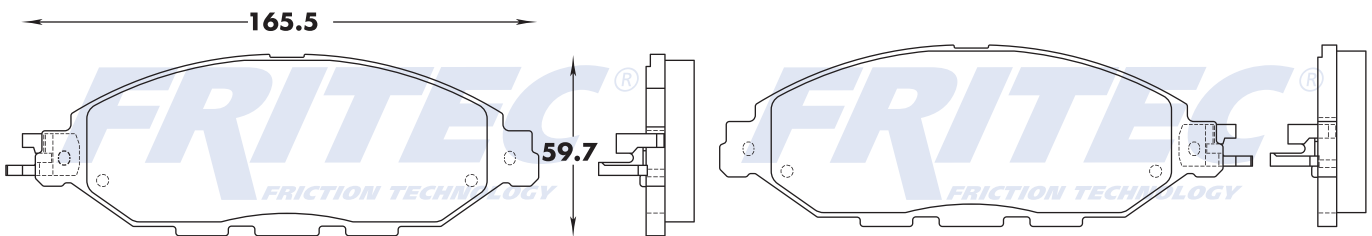

707

8878-Z D1650

D/F	T/R	E/T
X		15.9

8878-Z D1650

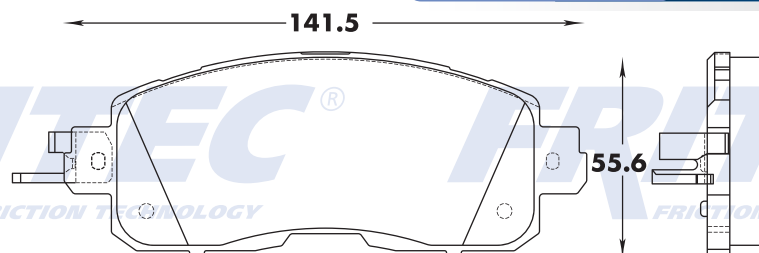

708

8881-Z D1611

D/F	T/R	E/T
X		18.0

8881-Z D1611

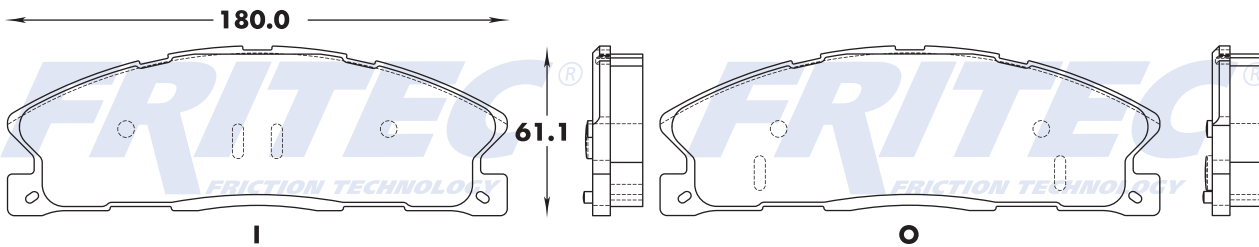

709

8882-Z D1653

D/F	T/R	E/T
X		19.3, 18.3

8882-Z D1653

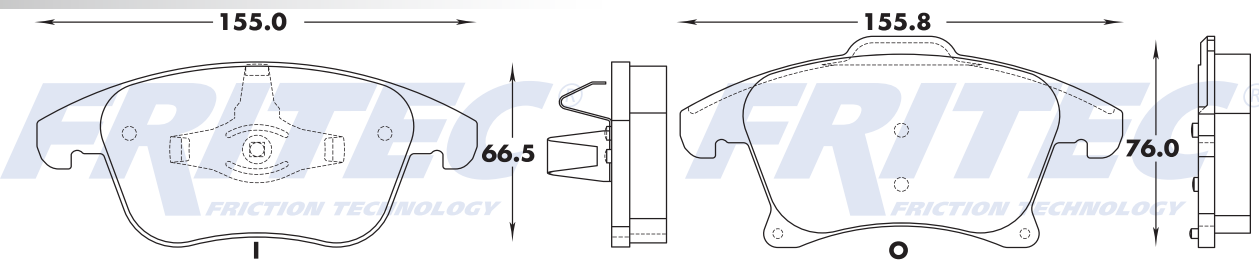

710

8883-Z D1654

D/F	T/R	E/T
X		15.8

8883-Z D1654

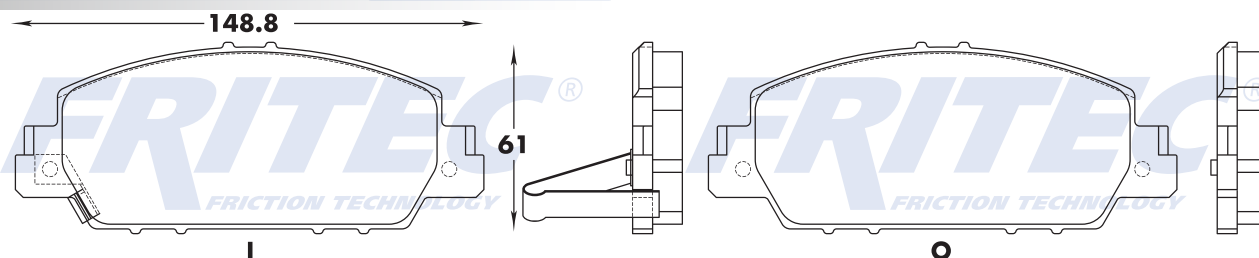

711

8891-Z D1663

D/F	T/R	E/T
X		15.8

8891-Z D1663

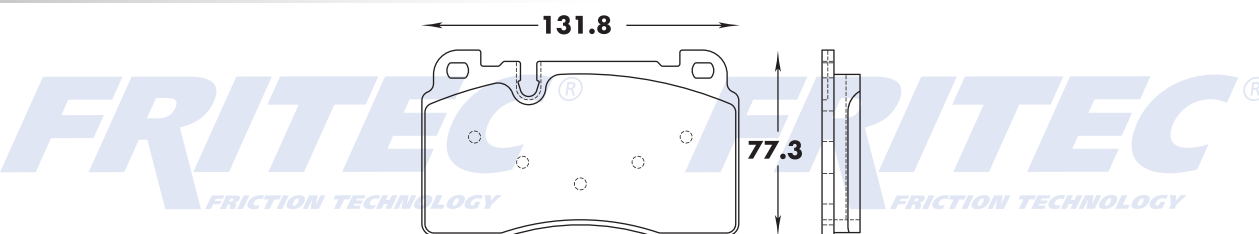

712

8893-Z D1665

D/F	T/R	E/T
X		15.0

8893-Z D1665

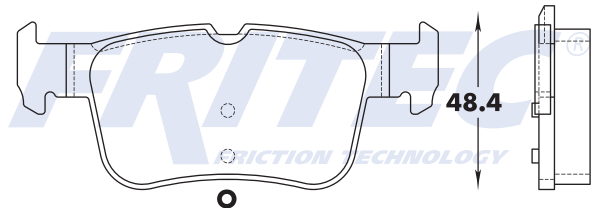
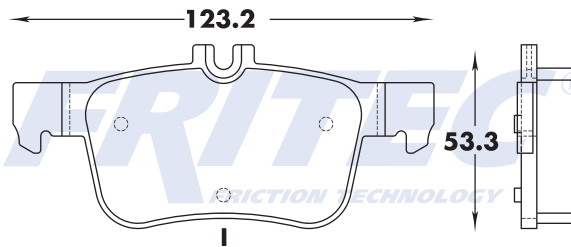

713

8896-Z D1668

D/F	T/R	E/T
X		17.3, 17.0

8896-Z D1668

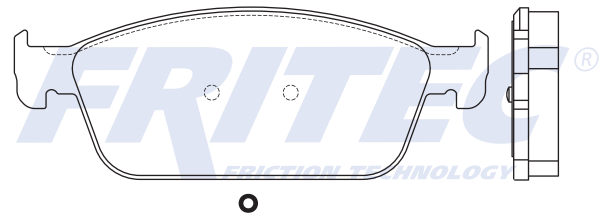
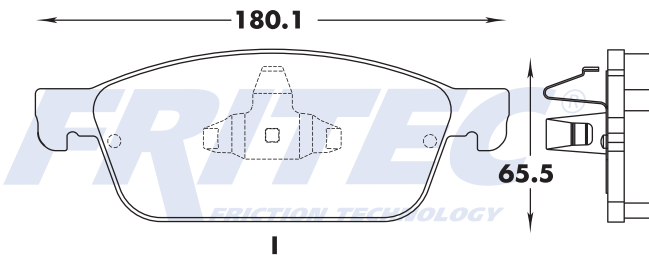

714

8905-Z D1676

D/F	T/R	E/T
X		15.5

8905-Z D1676

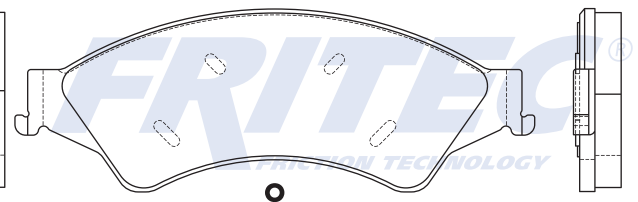
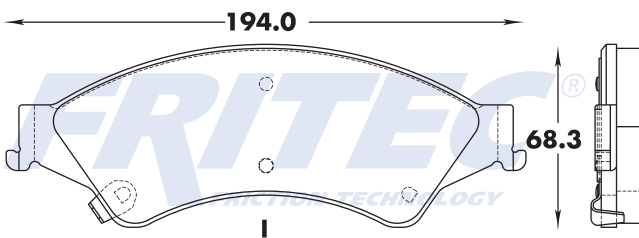

715

8906-Z D1677

D/F	T/R	E/T
X		16.3

8906-Z D1677

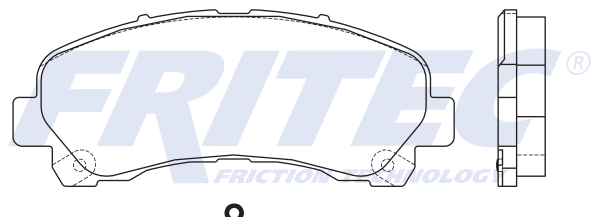
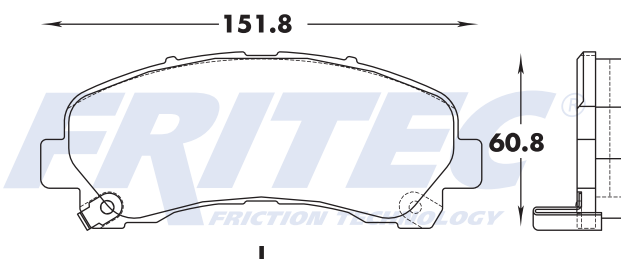

716

8906-Z1 D1736

D/F	T/R	E/T
X		15.9

8906-Z1 D1736

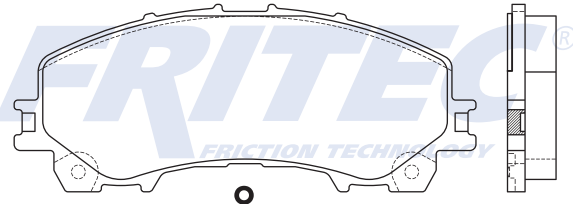
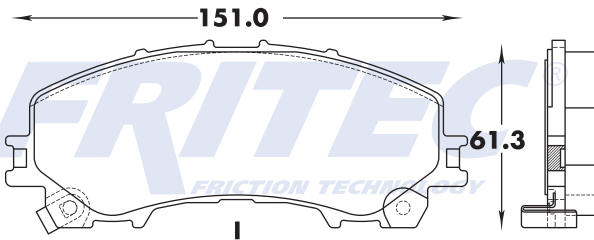

717

8908-Z D1679

D/F	T/R	E/T
X		14.3

8908-Z D1679

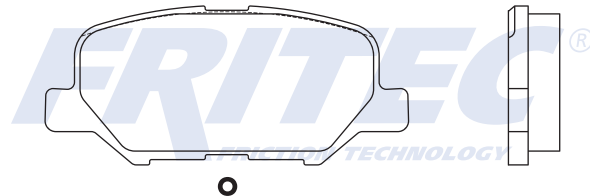
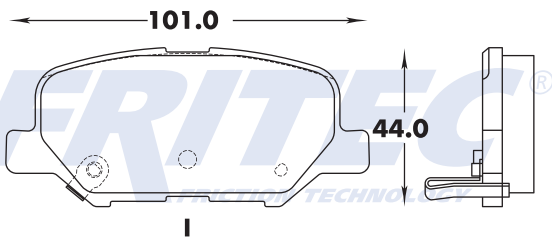

718

8909-Z D1680

D/F	T/R	E/T
X		18.2

8909-Z D1680

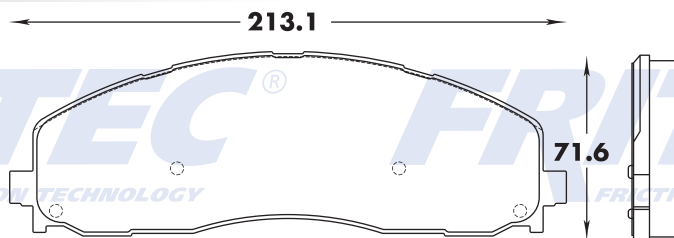

719

8918-Z D1691

D/F	T/R	E/T
X		18.2

8918-Z D1691

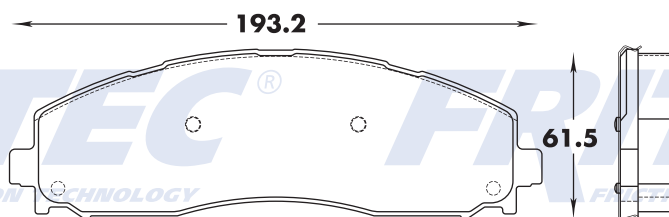

720

8932-Z D1709

D/F	T/R	E/T
X		17.6

8932-Z D1709

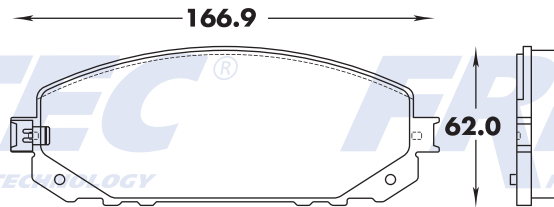

721

8936-Z D1711

D/F	T/R	E/T
X		15.5

8936-Z D1711

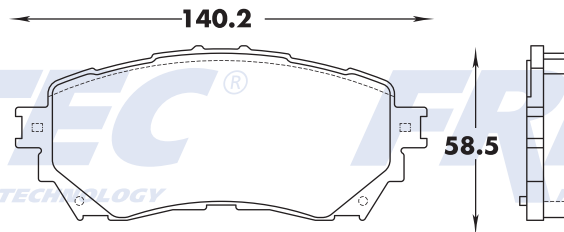

722

8942-Z D1717

D/F	T/R	E/T
X		17.5, 18.0

8942-Z D1717

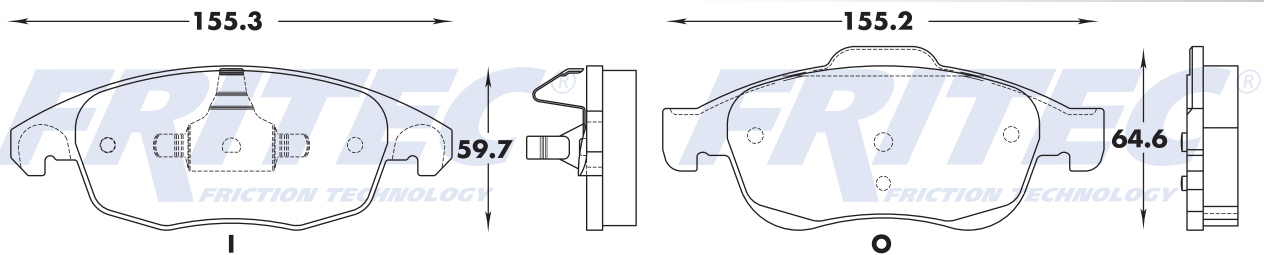

723

8952-Z D1728

D/F	T/R	E/T
X		15.8

8952-Z D1728

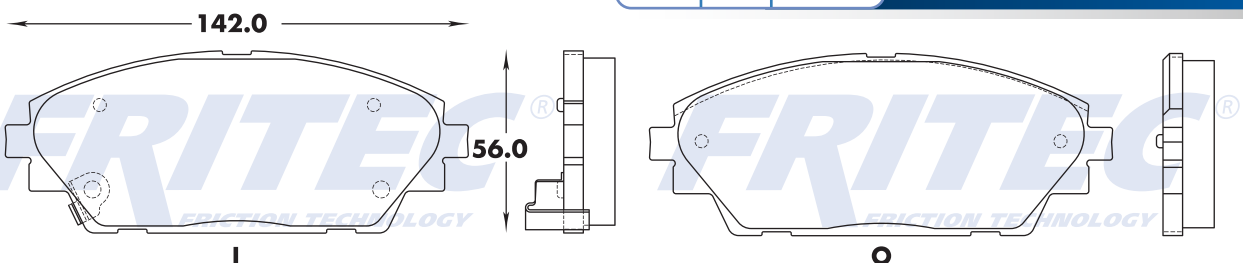

724

8953-Z D1729

D/F	T/R	E/T
X		13.7

8953-Z D1729

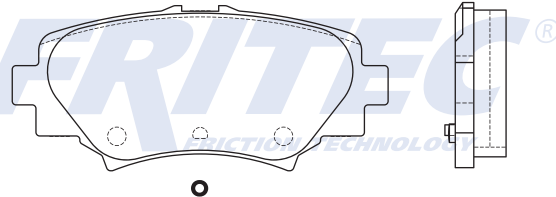
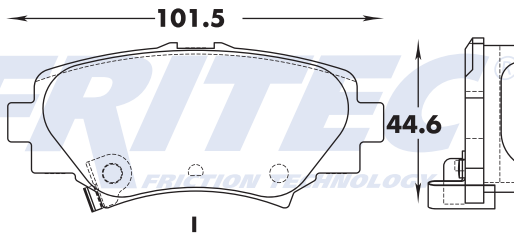

725

8956-Z D1731

D/F	T/R	E/T
X		14.5

8956-Z D1731

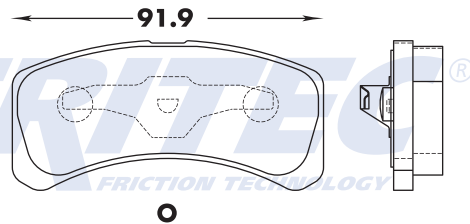
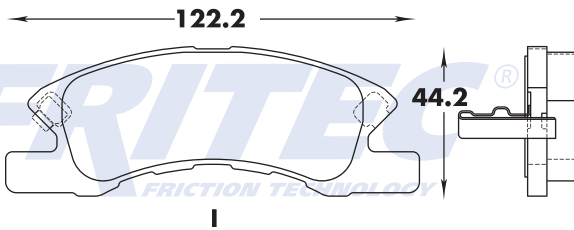

726

8958-Z D1734

D/F	T/R	E/T
X		16.5

8958-Z D1734

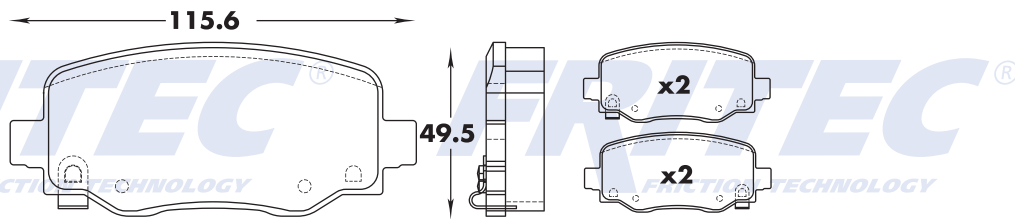

727

8974-Z D1746

D/F	T/R	E/T
X		20.3

8974-Z D1746

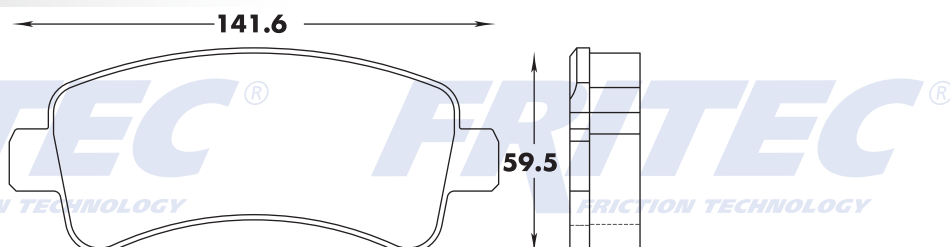

728

D/F	T/R	E/T
X		17.4, 17.8

8979-Z D1749

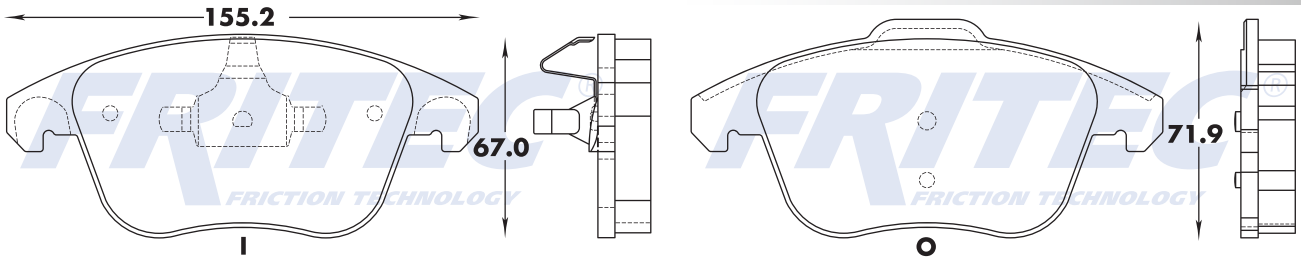

729

8987-Z D1759

D/F	T/R	E/T
X		15.5

8987-Z D1759

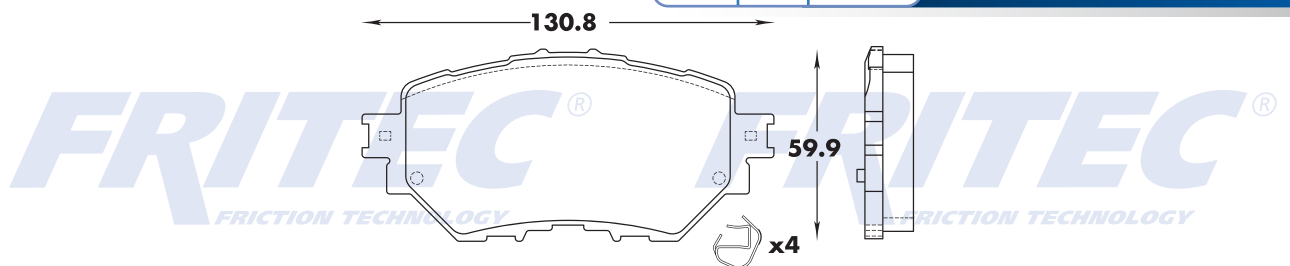

730

8989-Z D1760

D/F	T/R	E/T
X		19.0

8989-Z D1760

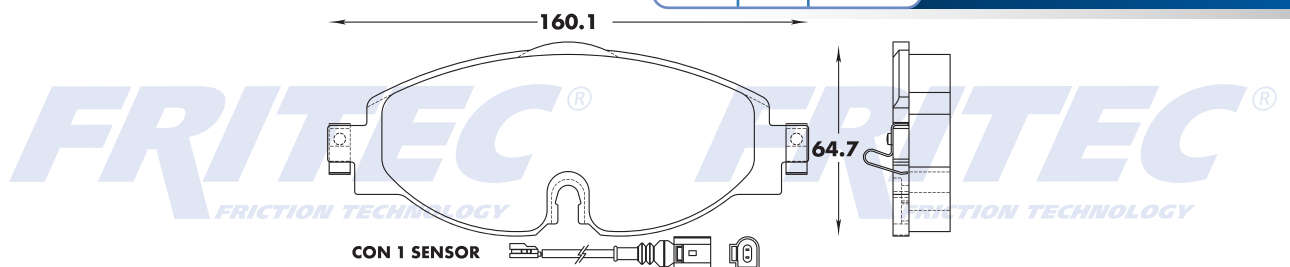

731

8990-Z D1761

D/F	T/R	E/T
X		15.2

8990-Z D1761

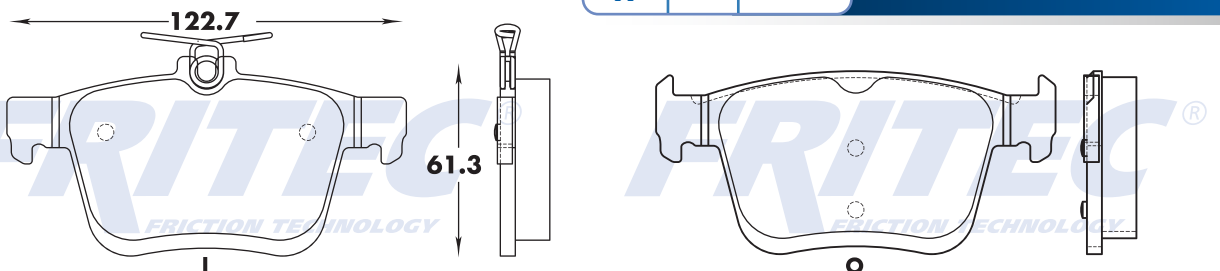

732

8997-Z D1766

D/F	T/R	E/T
X		17.4

8997-Z D1766

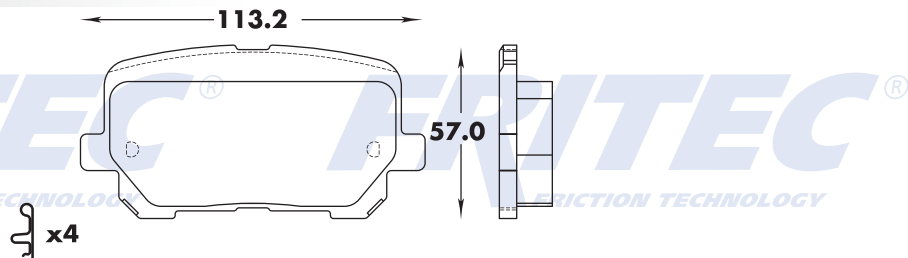

733

8998-Z D1767

D/F	T/R	E/T
X		20.4

8998-Z D1767

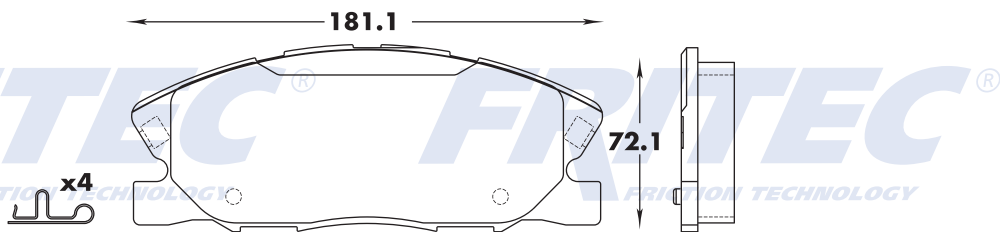

734

8X30-Z F391

D/F	T/R	E/T
X		18.2

8X30-Z F391

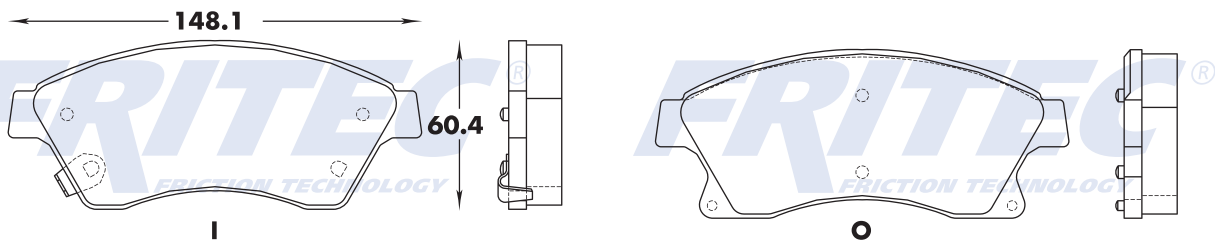

735

8804-Z D1592

D/F	T/R	E/T
X		13.6

8804-Z D1592

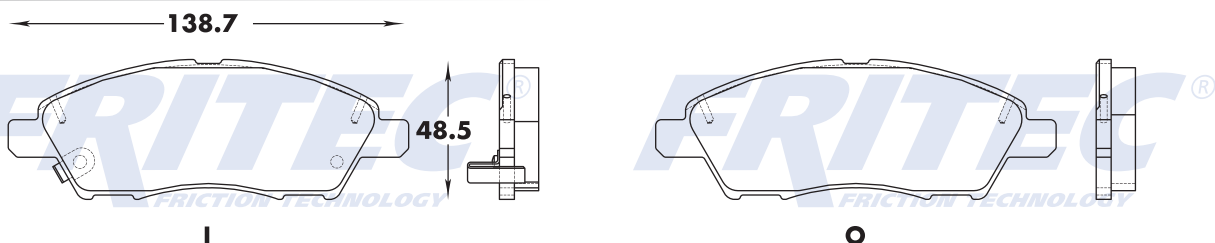

736

D/F	T/R	E/T
X		16.8

8X51-Z F386

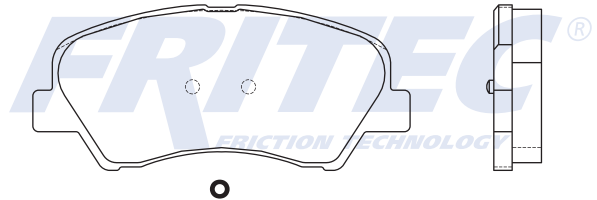
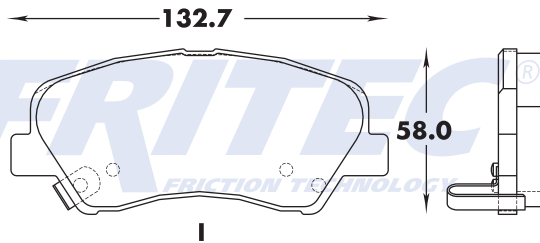

737

8X53-Z F520

D/F	T/R	E/T
X		16.5

8X53-Z F520

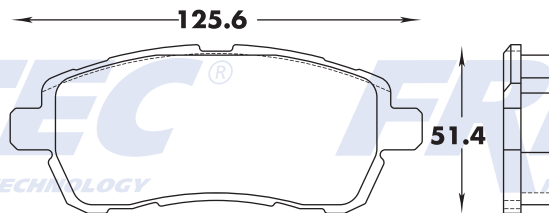

738

8X65-Z F467

D/F	T/R	E/T
X		16.2

8X65-Z F467

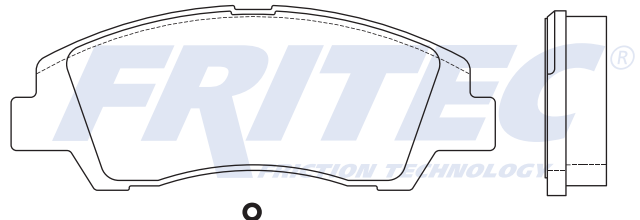
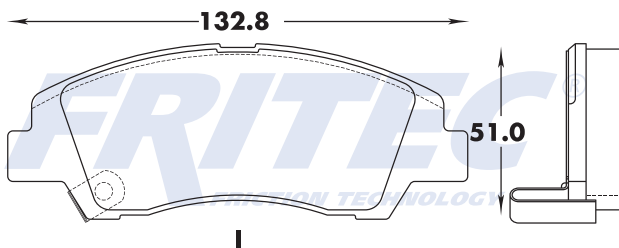

739

9006-Z D1776

D/F	T/R	E/T
X		17.0

9006-Z D1776

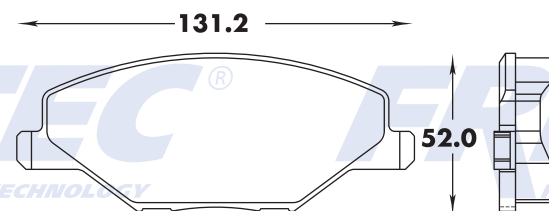

740

8Y30-Z F466

D/F	T/R	E/T
X		17.4

8Y30-Z F466

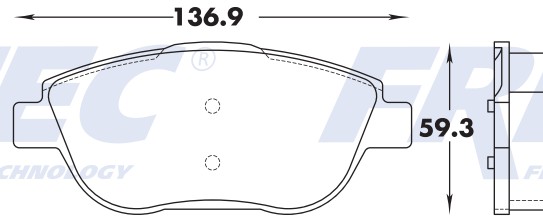

741

8Y31-Z F528

D/F	T/R	E/T
X		15.9

8Y31-Z F528

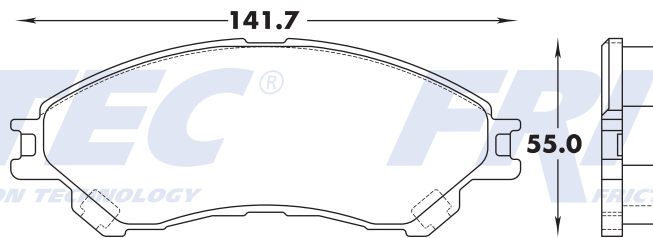

742

9004-Z D1774

D/F	T/R	E/T
X		16.4

9004-Z D1774

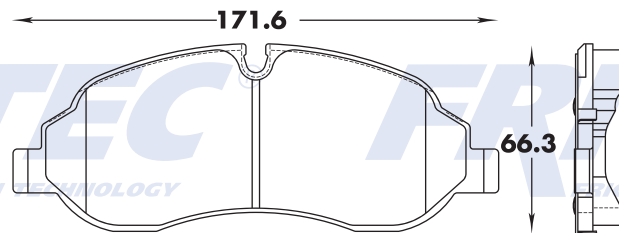

743

9005-Z D1775

D/F	T/R	E/T
X		17.5

9005-Z D1775

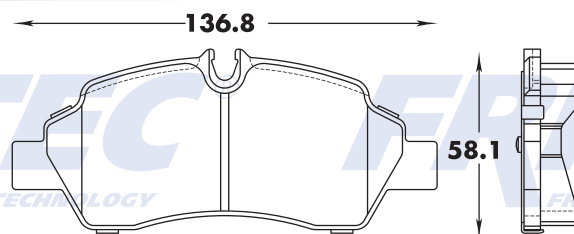

744

9008-Z D1779

D/F	T/R	E/T
X		16.5

9008-Z D1779

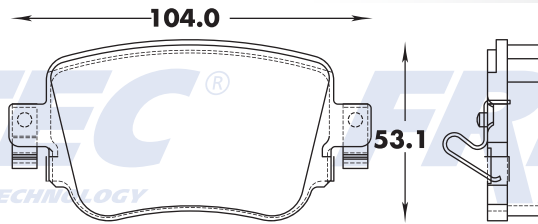

745

9013-Z D1786

D/F	T/R	E/T
X		16.5

9013-Z D1786

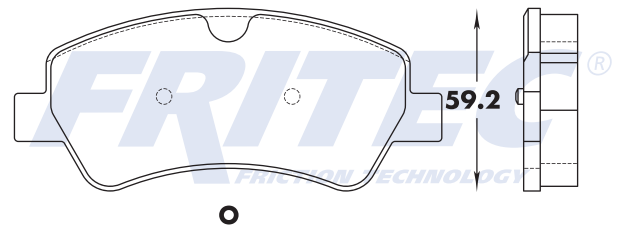
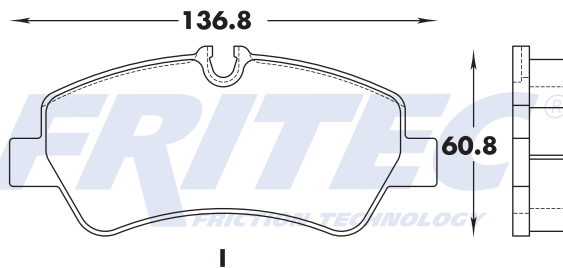

746

9014A-Z D1787

D/F	T/R	E/T
X		16.4

9014A-Z D1787

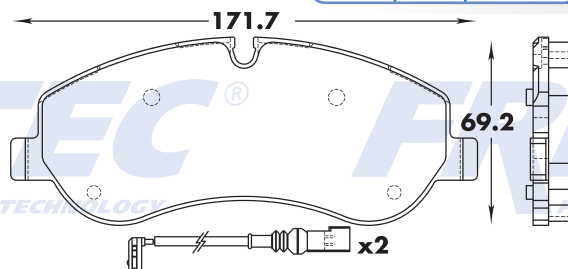

747

9017-Z D1490

D/F	T/R	E/T
X		18.2

9017-Z D1490

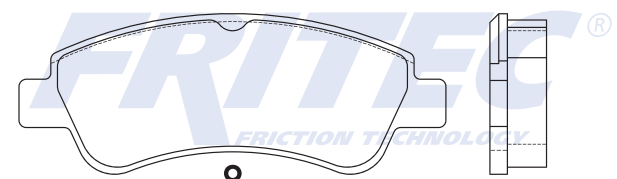
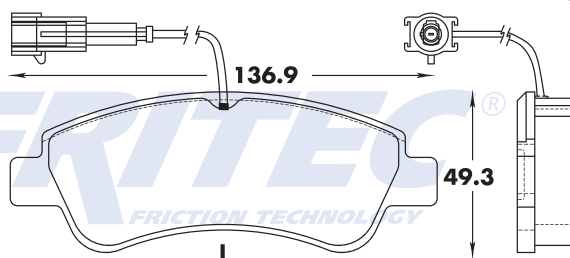

748

9018-Z D1790

D/F	T/R	E/T
X		17.1

9018-Z D1790

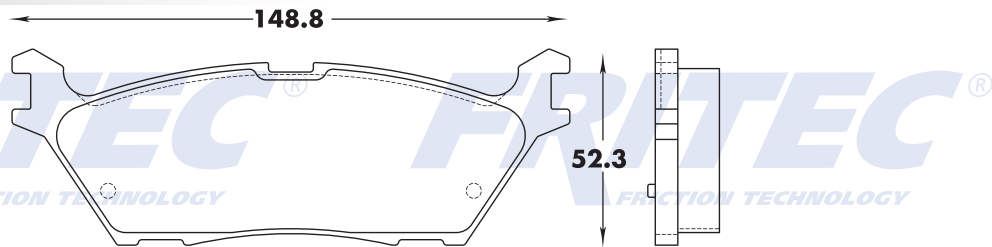

749

9020-Z D1791

D/F	T/R	E/T
X		16.9

9020-Z D1791

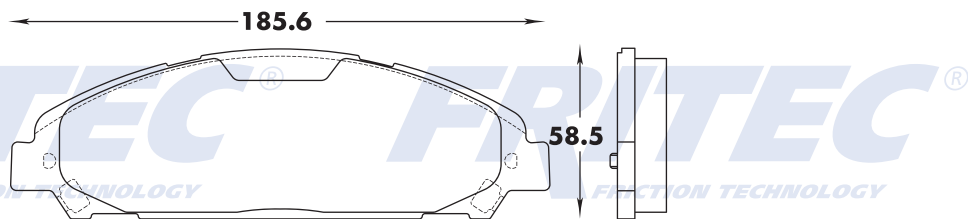

750

9022-Z D1793

D/F	T/R	E/T
X		16.5

9022-Z D1793

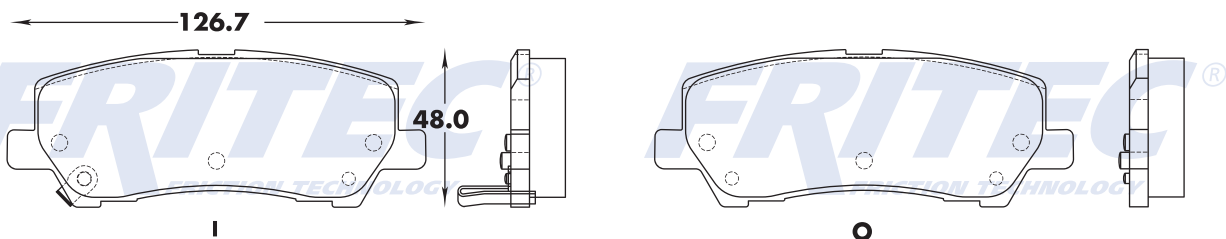

751

9035-Z D1826

D/F	T/R	E/T
X		16.5

9035-Z D1826

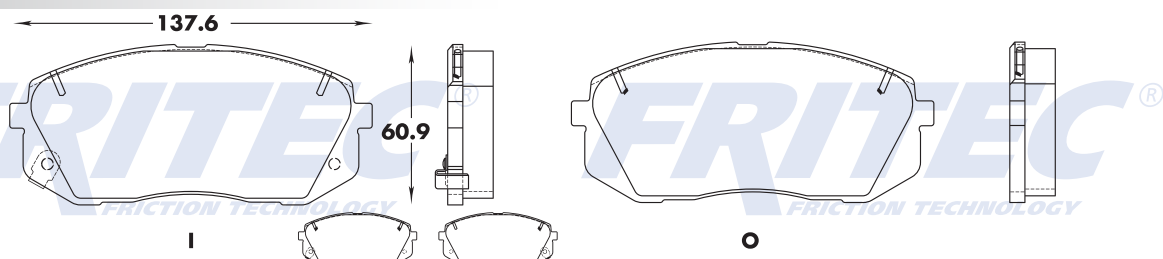

752

9049-Z D1815

D/F	T/R	E/T
X		16.5

9049-Z D1815

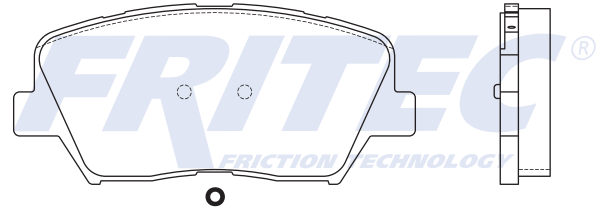
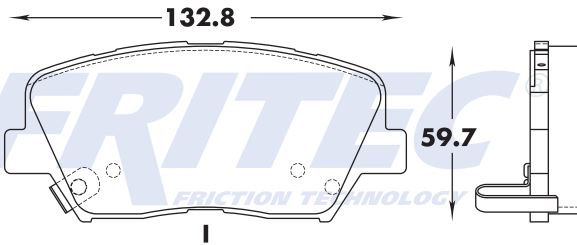

753

9053-Z D1818

D/F	T/R	E/T
X		17.1

9053-Z D1818

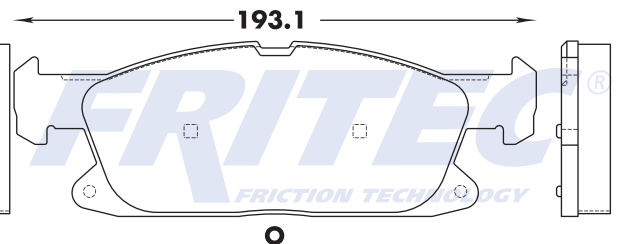
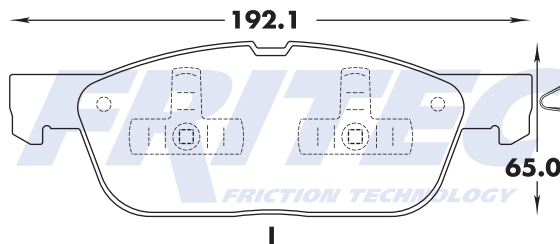

754

9069-Z D1841

D/F	T/R	E/T
X		16.0

9069-Z D1841

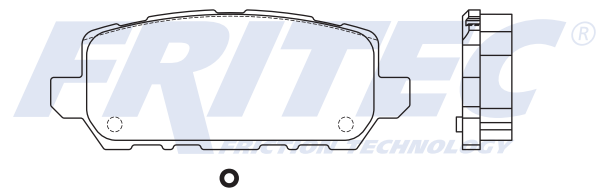
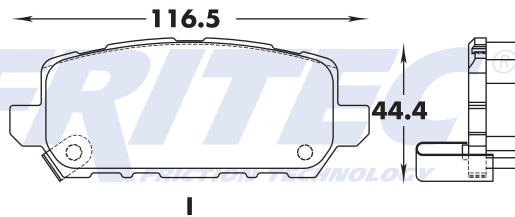

755

9073-Z D1846

D/F	T/R	E/T
X		14.5

9073-Z D1846

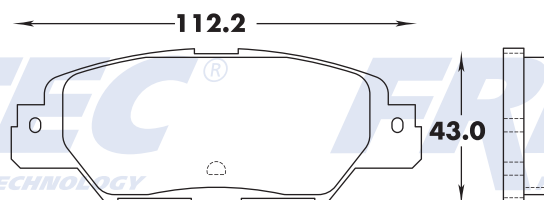

756

9075-Z D1847

D/F	T/R	E/T
X		16.8

9075-Z D1847

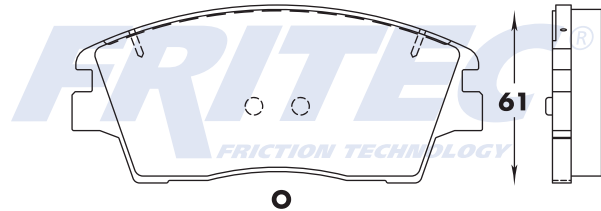
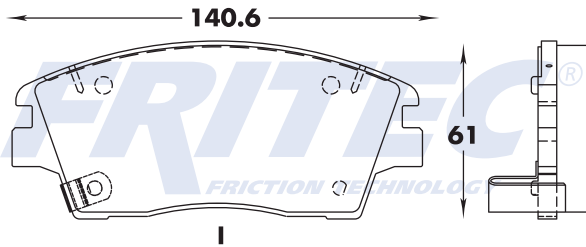

757

9081-Z D1852

D/F	T/R	E/T
X		15.3

9081-Z D1852

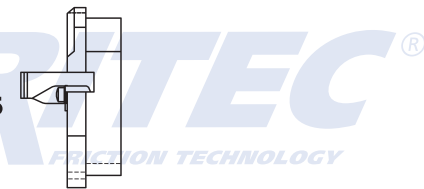
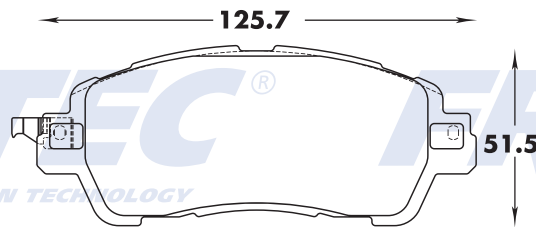

758

9093-Z D1864

D/F	T/R	E/T
X		17.0

9093-Z D1864

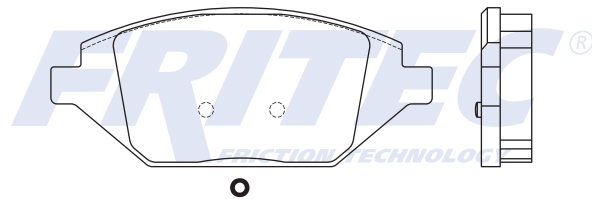
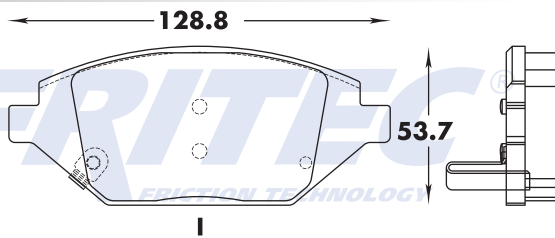

759

9104-ZD1876

D/F	T/R	E/T
X		15.1

9104-Z D1876

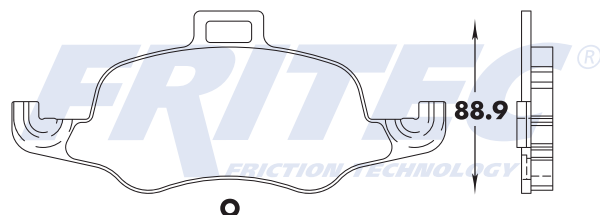
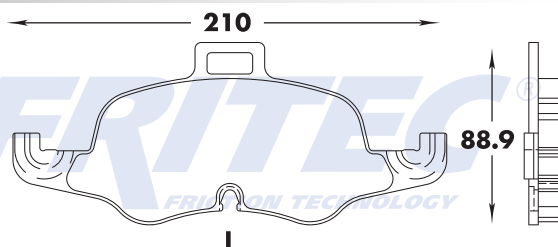

760

9106-Z D1878

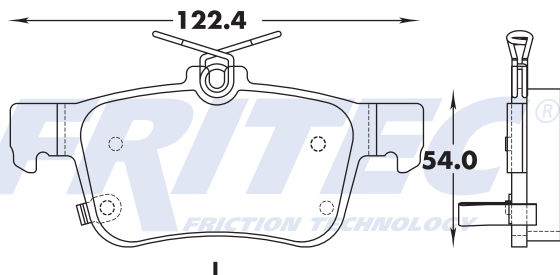

D/F	T/R	E/T
X		14.5

9106-Z D1878

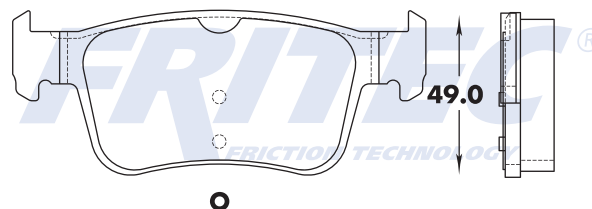

761

9114-Z D1886

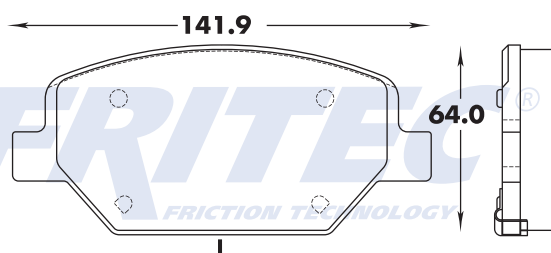

D/F	T/R	E/T
X		16.8

9114-Z D1886

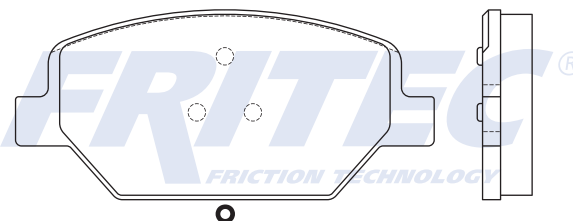

762

9157-Z D1934

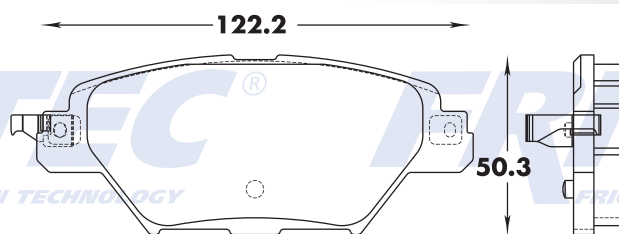

D/F	T/R	E/T
X		14.4

9157-Z D1934

763

9249-Z D2018

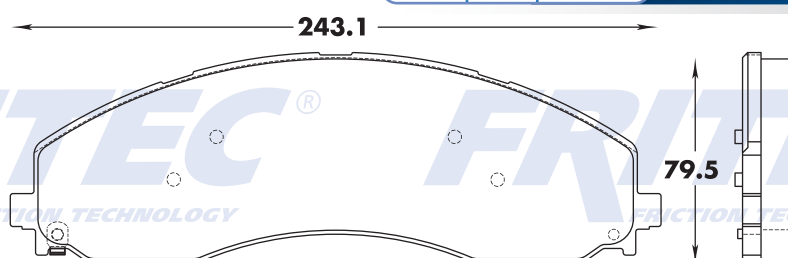

D/F	T/R	E/T
X		20.5

9249-Z D2018

764

9254-Z D2024

D/F	T/R	E/T
X		17.0

9254-Z D2024

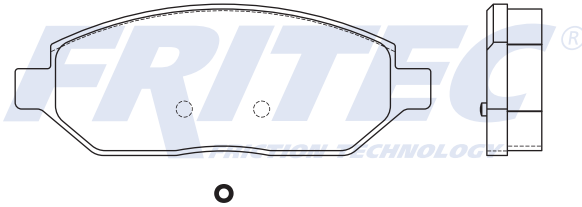
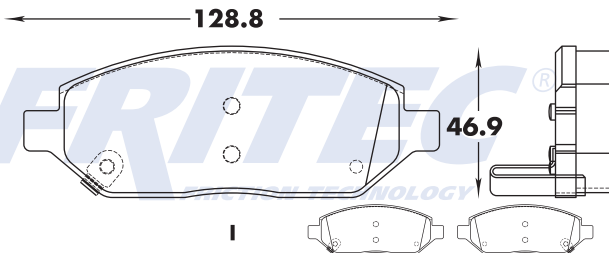

765

9268-Z D2037

D/F	T/R	E/T
X		15.7

9268-Z D2037

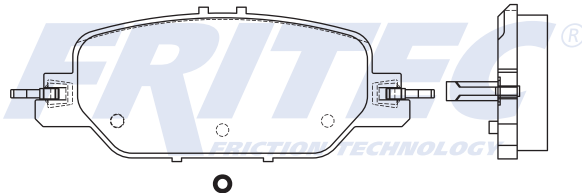
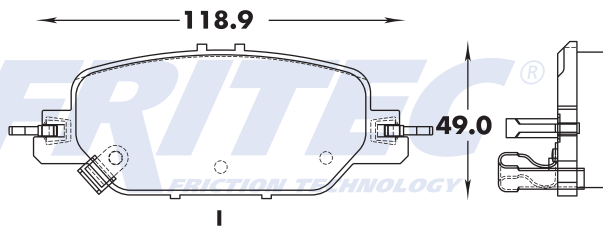

766

9269-Z D2038

D/F	T/R	E/T
X		15.4

9269-Z D2038

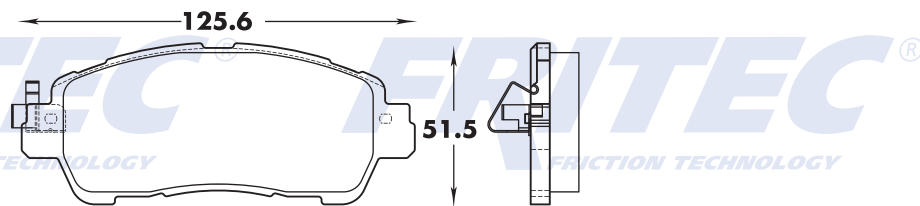

767

9326-Z1 D2058

D/F	T/R	E/T
X		15.6

9326-Z1 D2058

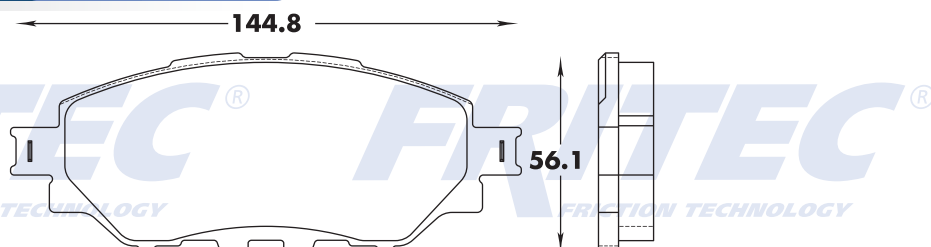

768

9X49-Z F529

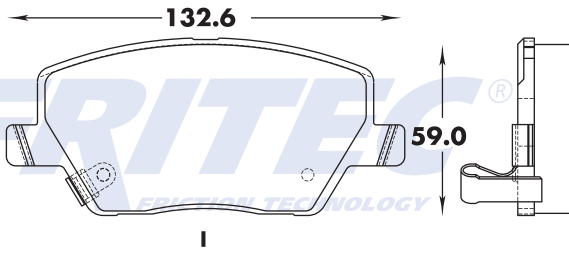

D/F	T/R	E/T
X		18.2

9X49-Z F529

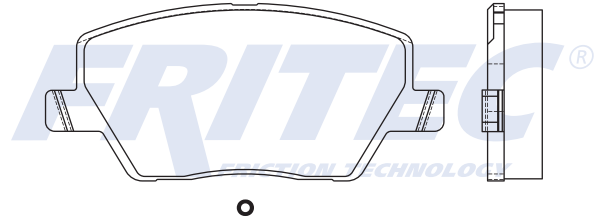

FRITEC[®]
FRICTION TECHNOLOGY



Sección 13 / Section 13
Balata freno de tambor
GUÍA ILUSTRADA / ILLUSTRATED GUIDE

BALATA FRENO DE TAMBOR

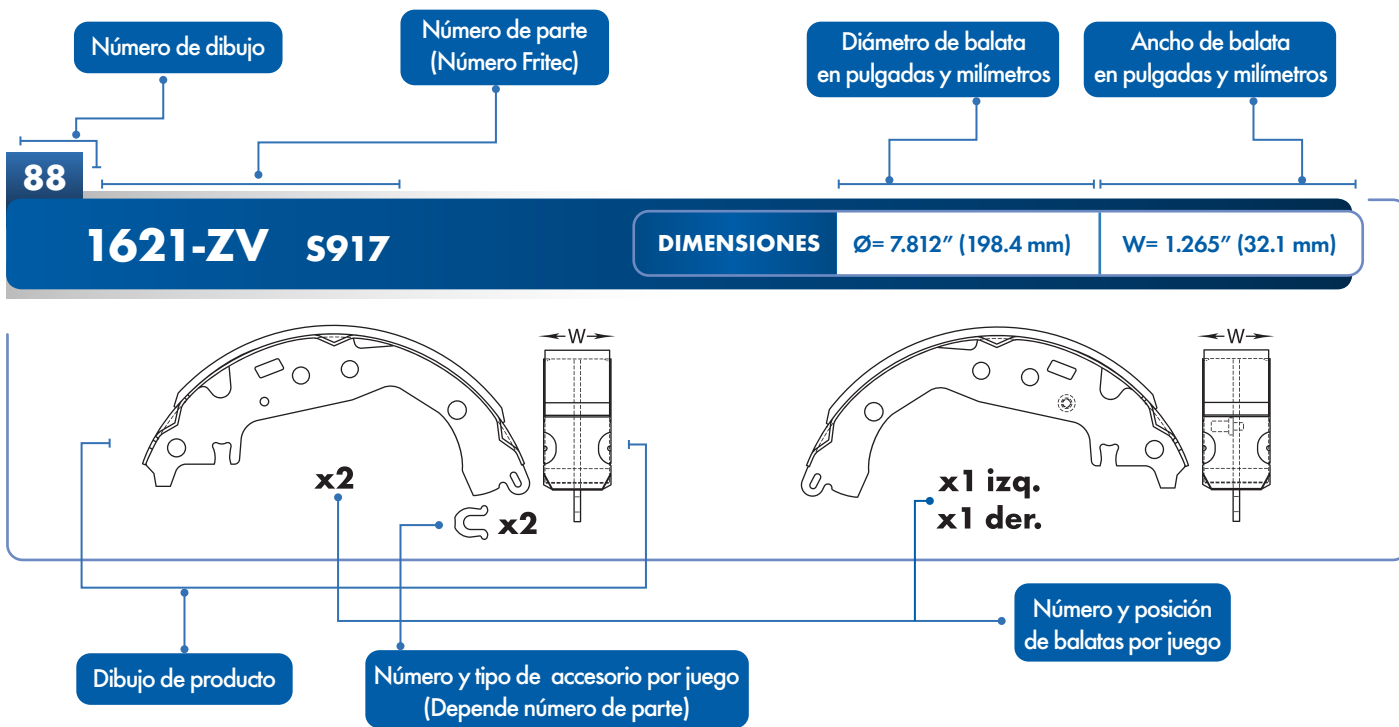

1

DIMENSIONES Ø= 9.060" (230.0 mm) W= 1.560" (39.5 mm)

882-ZV S315

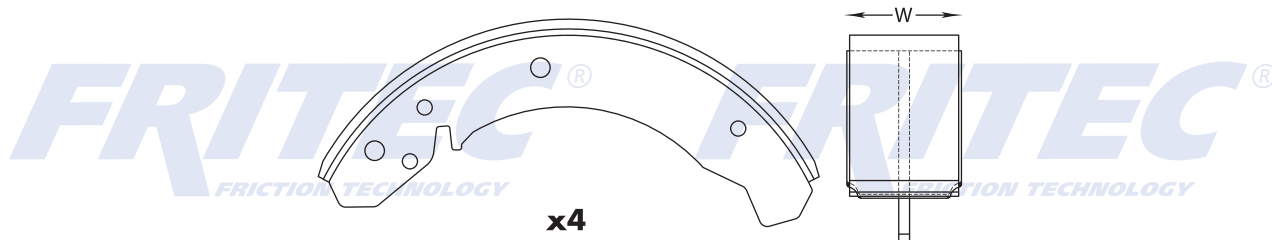

2

DIMENSIONES Ø= 7.258" (184.4 mm) W= 1.180" (30.0 mm)

1666-ZV S995

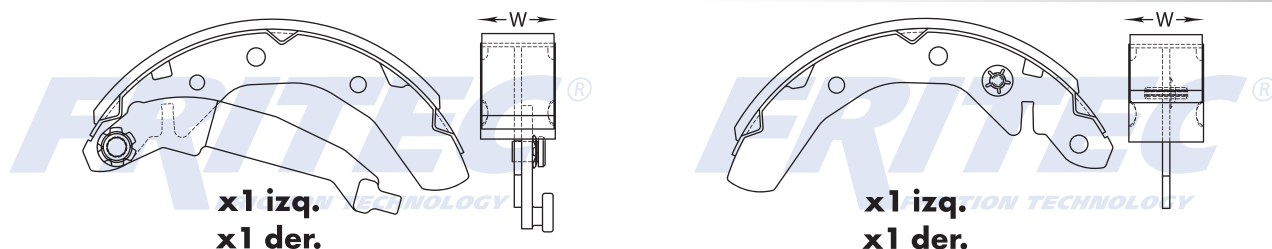

3

DIMENSIONES Ø= 10.000" (254.0 mm) W= 3.000" (76.2 mm)

1303K-ZR S842

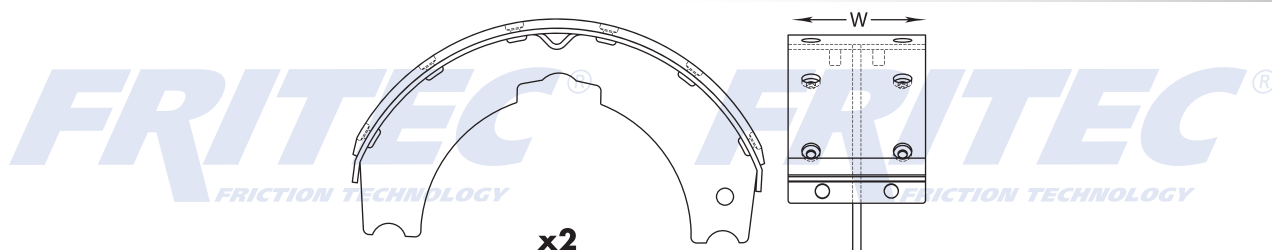

4

DIMENSIONES Ø= 8.000" (203.0 mm) W= 1.409" (35.7 mm)

1350-ZV S501

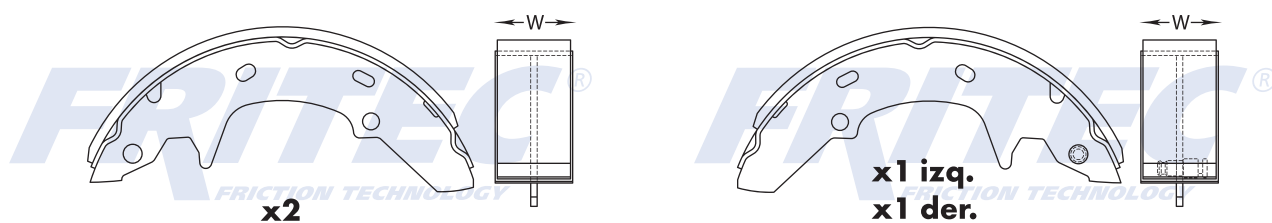

5

1353-ZV S495

DIMENSIONES Ø= 7.870" (200.0 mm) W= 1.570" (39.9 mm)

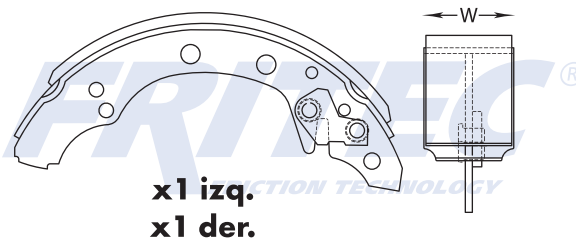
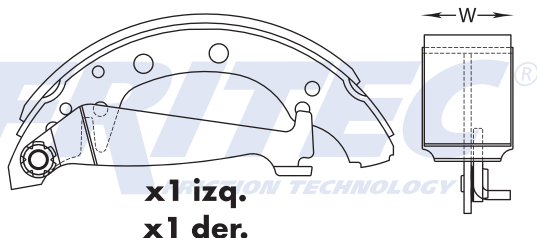

6

1354-ZV S559

DIMENSIONES Ø= 7.090" (180.0 mm) W= 1.180" (30.0 mm)

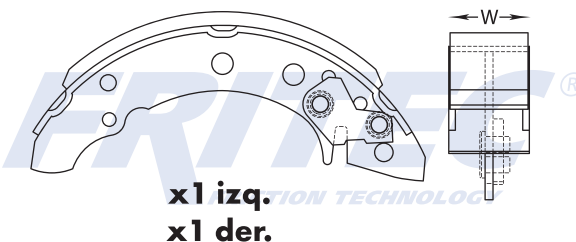
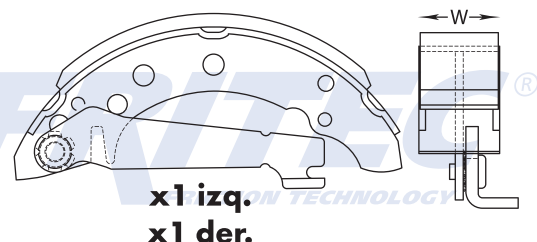

7

1358-ZV S505

DIMENSIONES Ø= 10.000" (254.0 mm) W= 1.970" (50.0 mm)

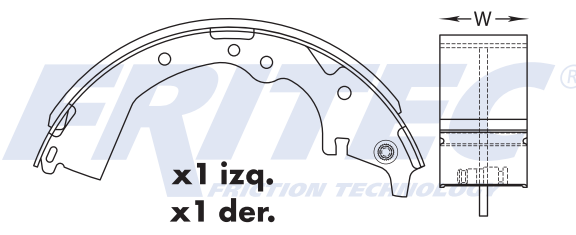
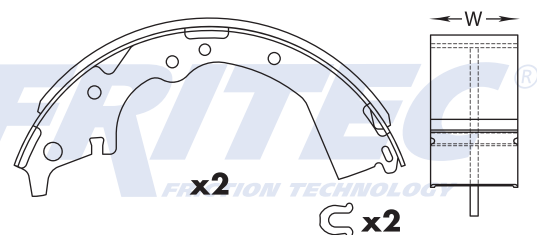

8

1358-ZIV S804

DIMENSIONES Ø= 10.000" (254.0 mm) W= 2.050" (52.1 mm)

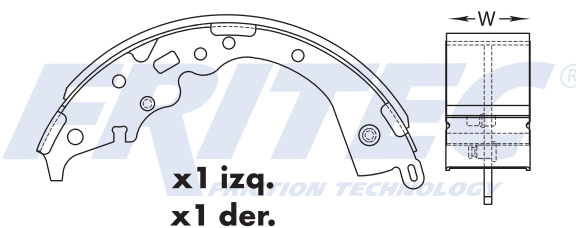
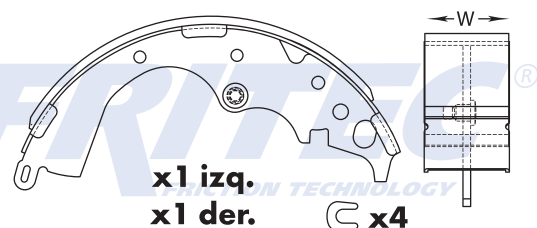

9

DIMENSIONES $\varnothing = 10.000''$ (254.0 mm) $W = 1.990''$ (50.5 mm)

1358-Z2V S871

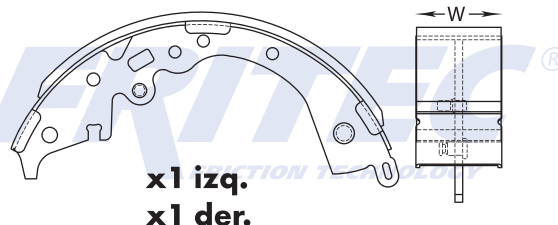
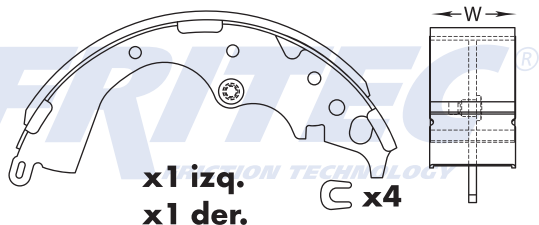

10

DIMENSIONES $\varnothing = 10.000''$ (254.0 mm) $W = 2.000''$ (50.8 mm)

1360-ZV S619

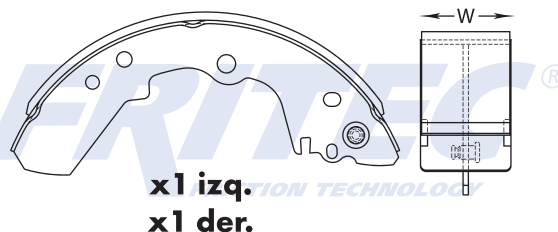
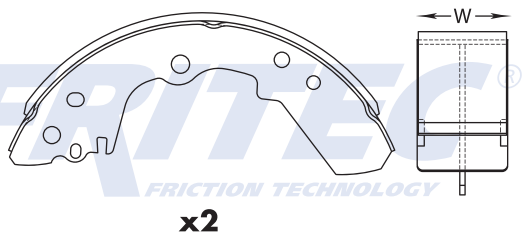

11

DIMENSIONES $\varnothing = 7.870''$ (200.0 mm) $W = 1.380''$ (35.0 mm)

1364-ZV S576

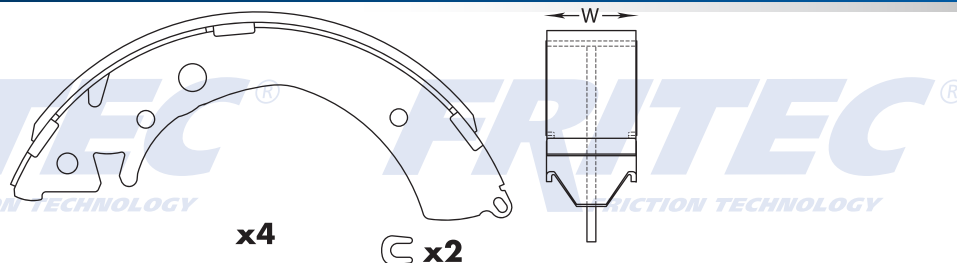

12

DIMENSIONES $\varnothing = 7.870''$ (200.0 mm) $W = 1.280''$ (32.5 mm)

1365-ZV S519

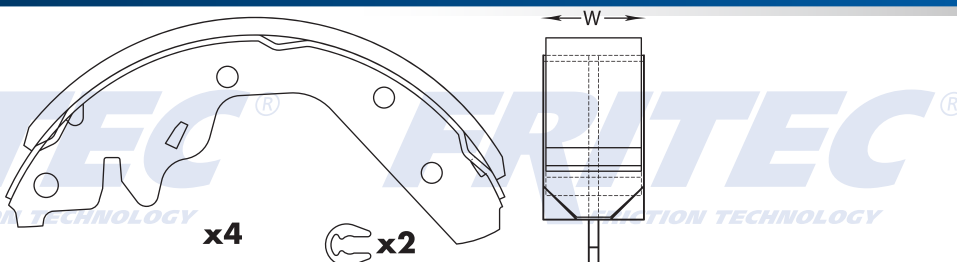

13

1366-ZV S520

DIMENSIONES

Ø= 8.660" (220.0 mm)

W= 1.654" (42.0 mm)

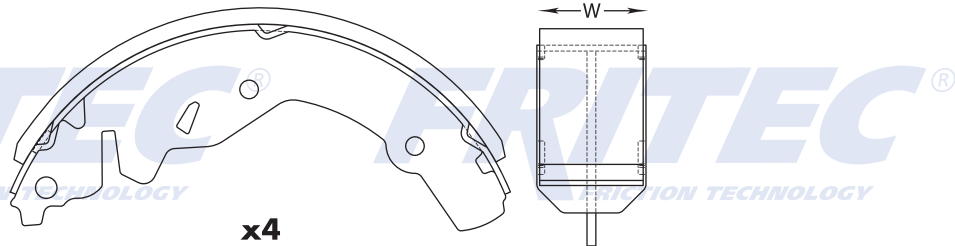

14

1370-ZV S524

DIMENSIONES

Ø= 9.985" (254.0 mm)

W= 2.000" (50.8 mm)

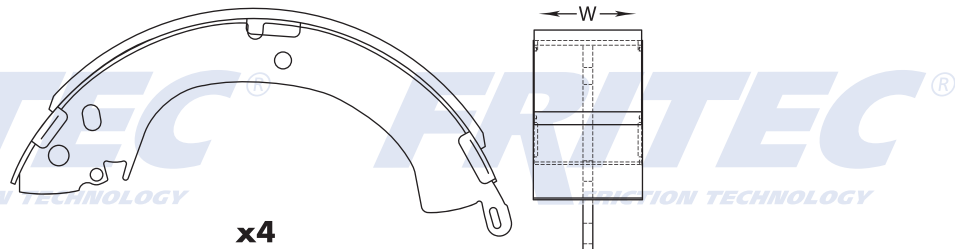

15

1373-ZV S532

DIMENSIONES

Ø= 7.090" (180.0 mm)

W= 1.380" (35.0 mm)

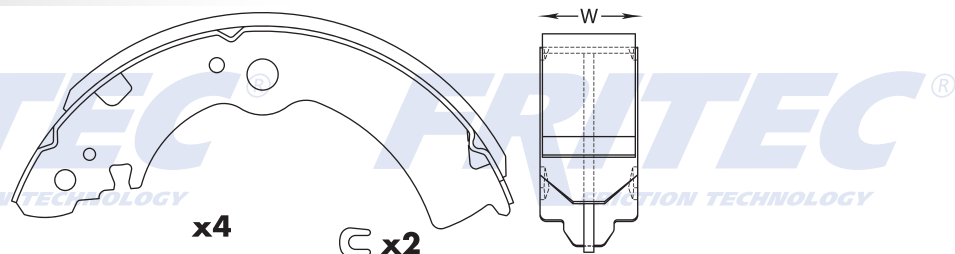

16

1379-ZV S707

DIMENSIONES

Ø= 7.090" (180.0 mm)

W= 1.180" (30.0 mm)

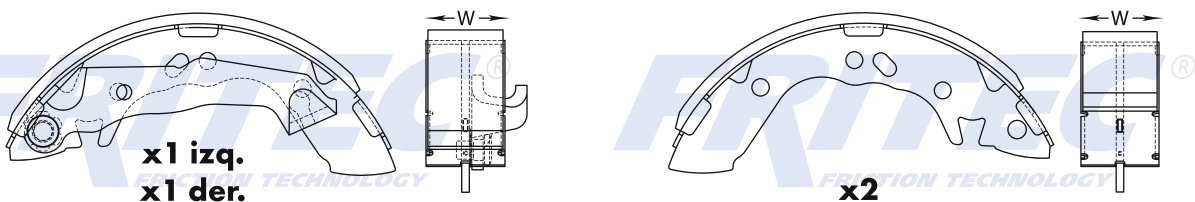

17

DIMENSIONES $\varnothing = 8.875''$ (225.4 mm) $W = 1.600''$ (40.6 mm)

1381-ZV S607

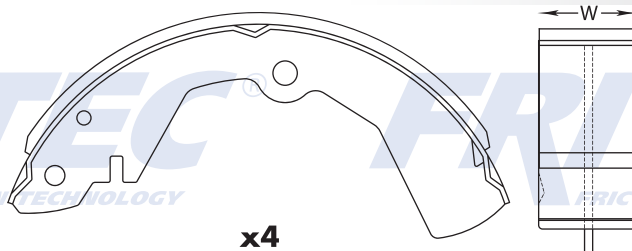

x4

18

DIMENSIONES $\varnothing = 8.860''$ (225.0 mm) $W = 1.770''$ (45.0 mm)

1394-ZV S636

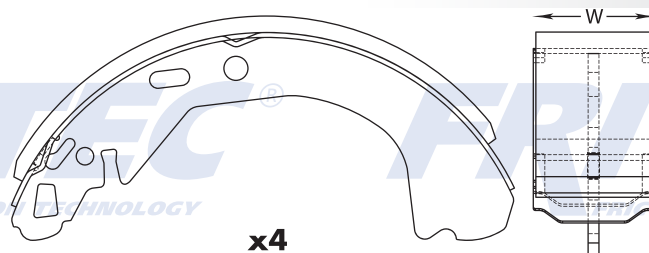

x4

19

DIMENSIONES $\varnothing = 9.840''$ (250.0 mm) $W = 1.770''$ (45.0 mm)

1396-ZV S618

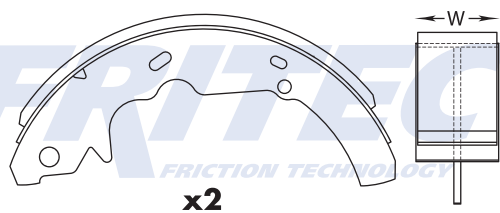

x2

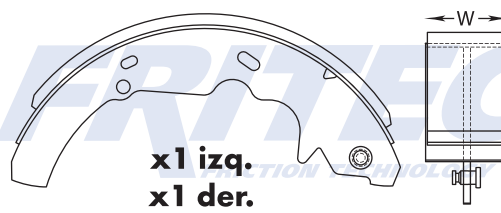

x1 izq.
x1 der.

20

DIMENSIONES $\varnothing = 11.560''$ (293.6 mm) $W = 2.000''$ (51.8 mm)

1397-ZV S589

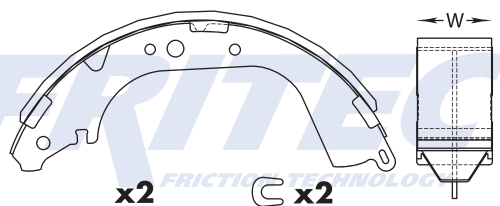

x2

x2

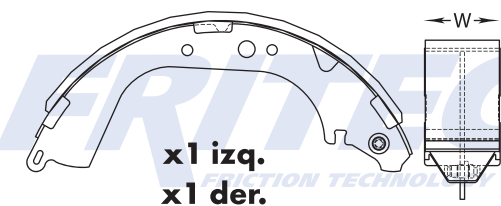

x1 izq.
x1 der.

21

1397-Z1V S764

DIMENSIONES Ø= 11.610" (249.2 mm) W= 2.040" (51.8 mm)

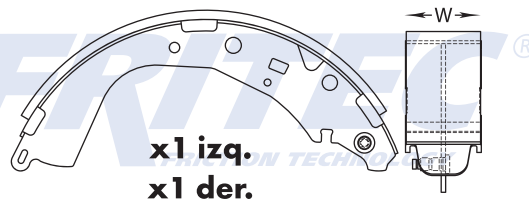
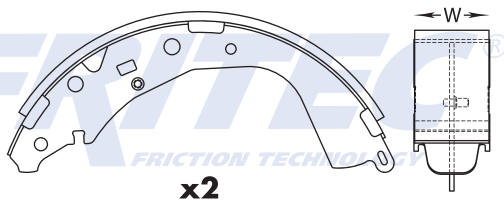

22

1399-ZV S574

DIMENSIONES Ø= 10.240" (260.0 mm) W= 1.970" (50.0 mm)

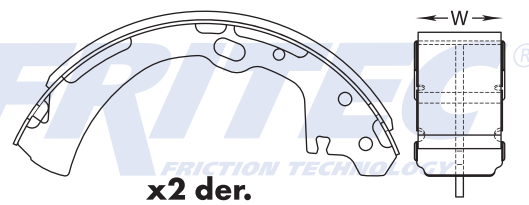
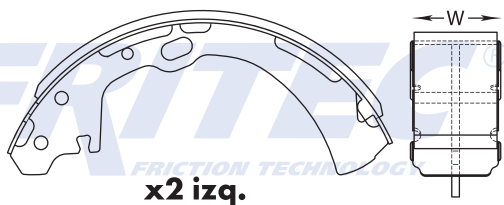

23

1665-ZV S994

DIMENSIONES Ø= 7.870" (200.0 mm) W= 1.100" (28.0 mm)

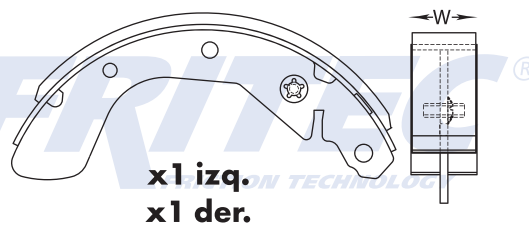
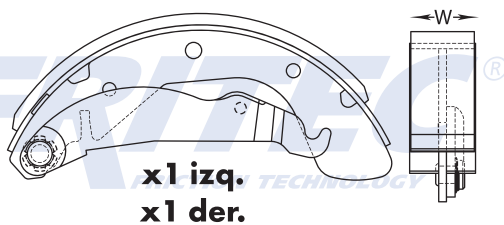

24

1670-ZV S999

DIMENSIONES Ø= 9.000" (228.6 mm) W= 1.457" (37.0 mm)

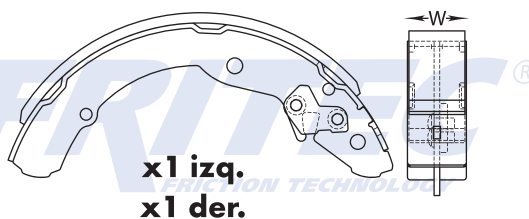
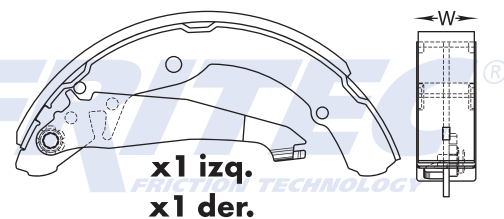

25

DIMENSIONES $\varnothing = 11.366''$ (288.6 mm) $W = 3.050''$ (77.4 mm)

1714-ZV S1057

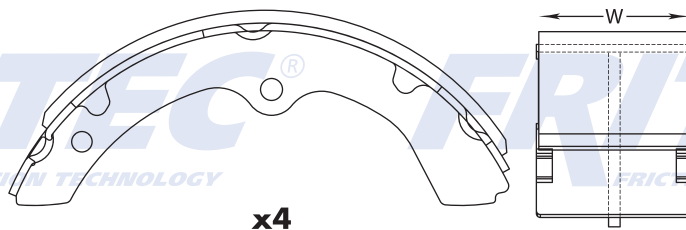

x4

26

DIMENSIONES $\varnothing = 10.000''$ (254.0 mm) $W = 2.240''$ (57.0 mm)

1404A S675

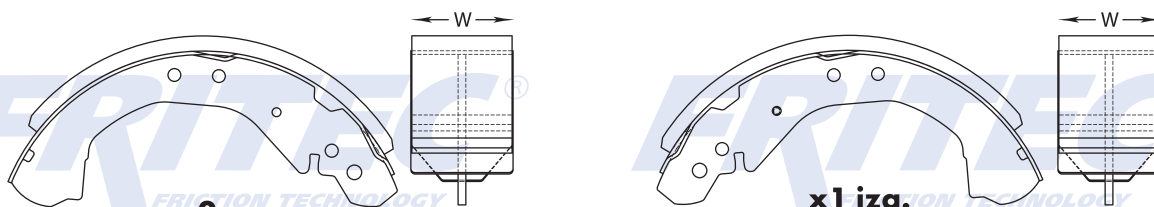

x2

**x1 izq.
x1 der.**

27

DIMENSIONES $\varnothing = 9.000''$ (228.6 mm) $W = 1.180''$ (30.0 mm)

1407-ZV S721

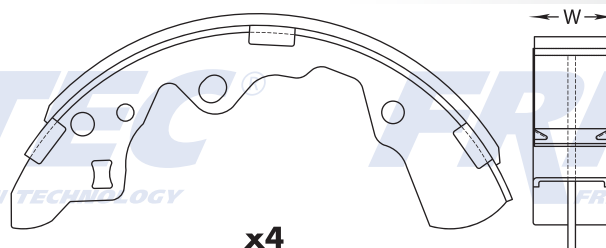

x4

28

DIMENSIONES $\varnothing = 8.660''$ (220.0 mm) $W = 1.400''$ (35.6 mm)

1429-ZV S627

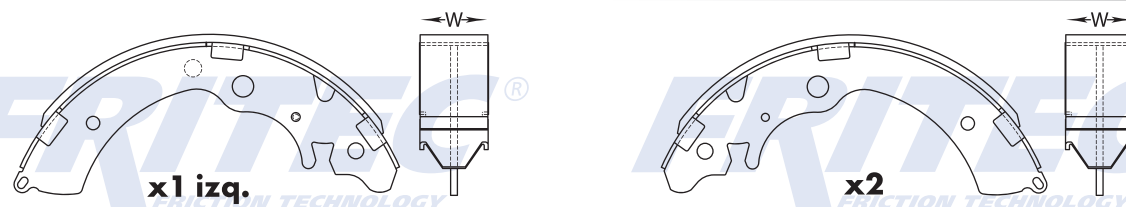

**x1 izq.
x1 der.**

x2

29

1433-ZV S631

DIMENSIONES Ø= 11.500" (292.1 mm) W= 2.040" (51.8 mm)

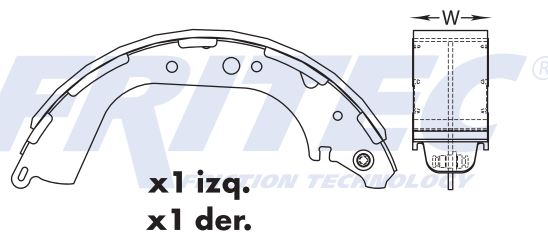
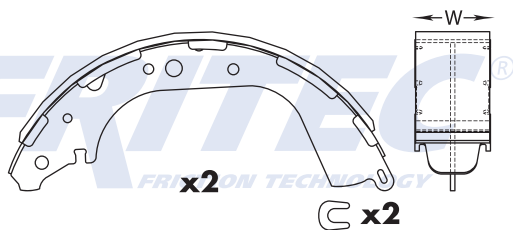

30

1437-ZV S984

DIMENSIONES Ø= 7.870" (200.0 mm) W= 1.250" (31.8 mm)

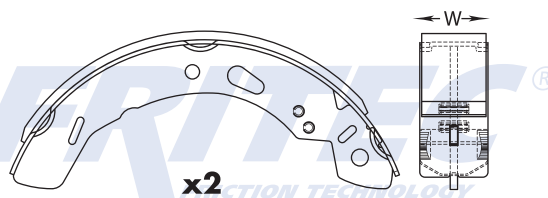
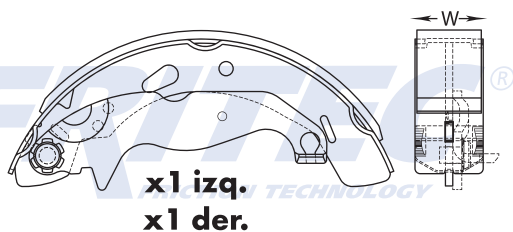

31

1437-Z1V S991

DIMENSIONES Ø= 7.870" (200.0 mm) W= 1.250" (31.8 mm)

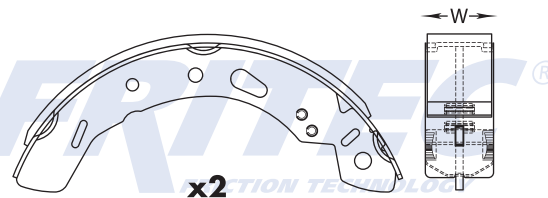
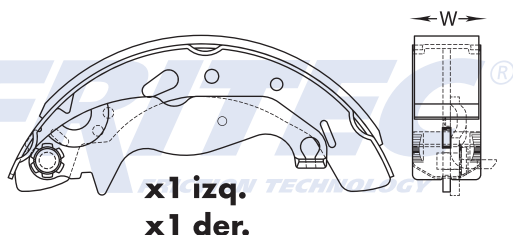

32

1438-ZV S638

DIMENSIONES Ø= 7.090" (180.0 mm) W= 1.170" (35.0 mm)

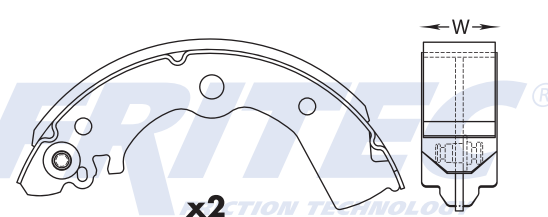
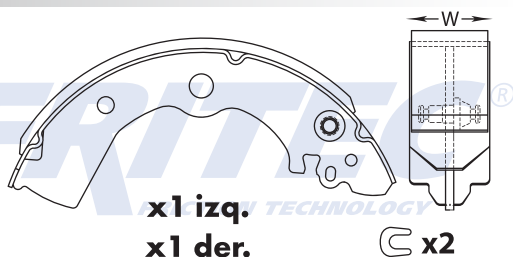

33

DIMENSIONES $\varnothing = 8.660''$ (220.0 mm) $W = 1.340''$ (34.0 mm)

1440-ZV S641

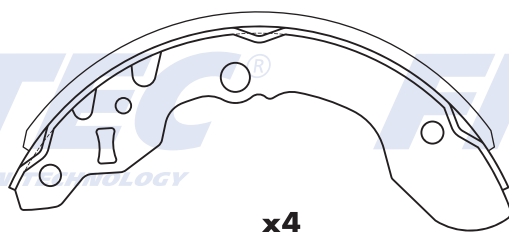

34

DIMENSIONES $\varnothing = 6.770''$ (172.0 mm) $W = 0.780''$ (19.8 mm)

1441-ZV S643

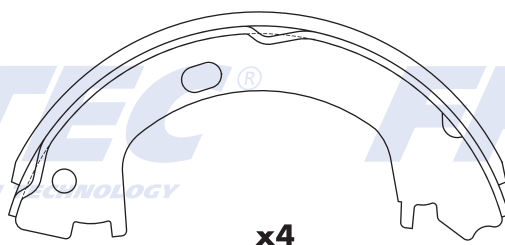

35

DIMENSIONES $\varnothing = 8.660''$ (220.0 mm) $W = 1.570''$ (40.0 mm)

1407-ZV S721

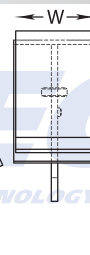
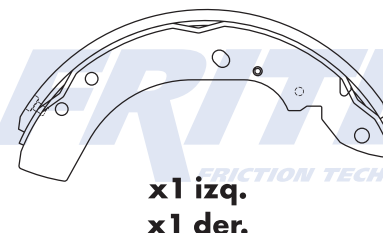
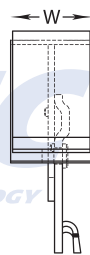
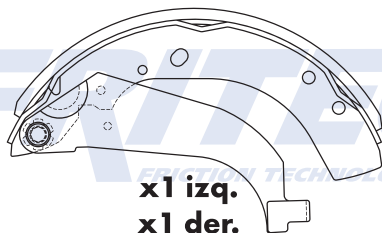

36

DIMENSIONES $\varnothing = 7.870''$ (200.0 mm) $W = 1.530''$ (38.9 mm)

1450-ZV S662

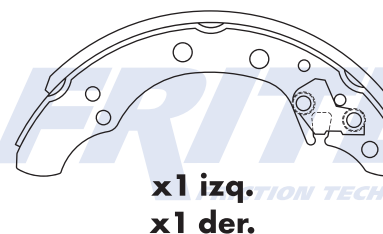
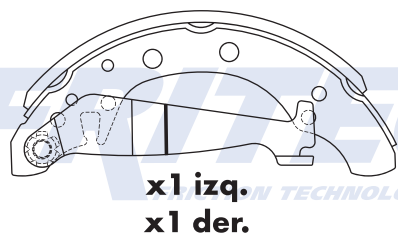

37

1450A-ZV S662

DIMENSIONES

Ø= 7.870" (200.0 mm)

W= 1.530" (38.9 mm)

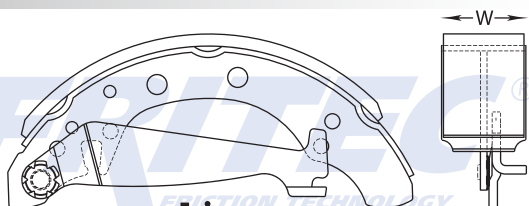

x1 izq.
x1 der.

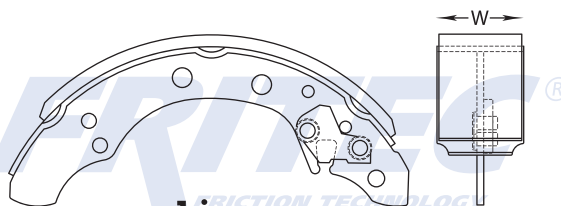

x1 izq.
x1 der.

38

1450B-ZV S495

DIMENSIONES

Ø= 7.870" (200.0 mm)

W= 1.530" (38.9 mm)

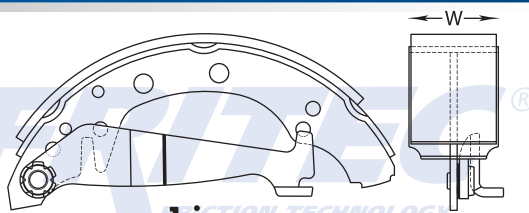

x1 izq.
x1 der.

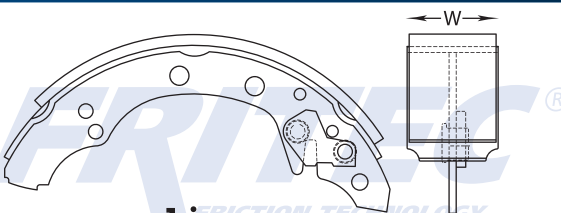

x1 izq.
x1 der.

39

1452-ZV S665

DIMENSIONES

Ø= 9.840" (250.0 mm)

W= 2.170" (55.0 mm)

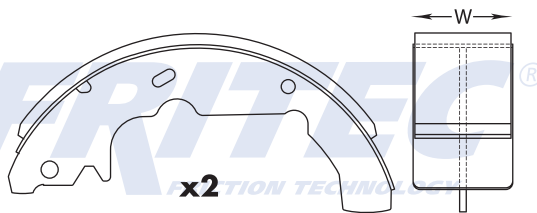

x2

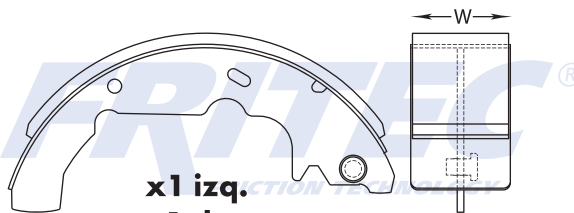

x1 izq.
x1 der.

40

1461-ZV S630

DIMENSIONES

Ø= 7.870" (200.0 mm)

W= 1.180" (30.0 mm)

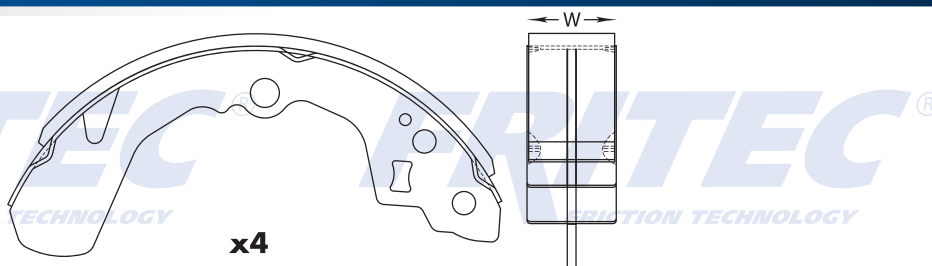

x4

41

DIMENSIONES Ø= 9.000" (228.6 mm) W= 1.380" (35.0 mm)

1462-ZV S919

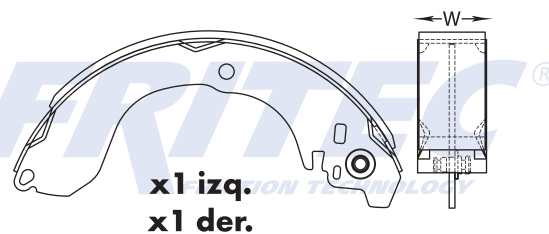
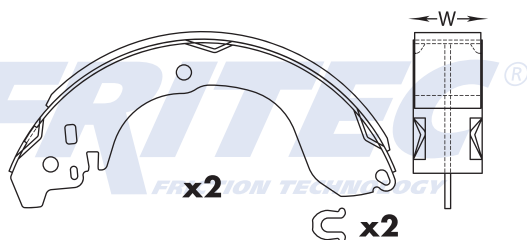

42

DIMENSIONES Ø= 7.870" (200.0 mm) W= 1.280" (32.5 mm)

1473-ZV S689

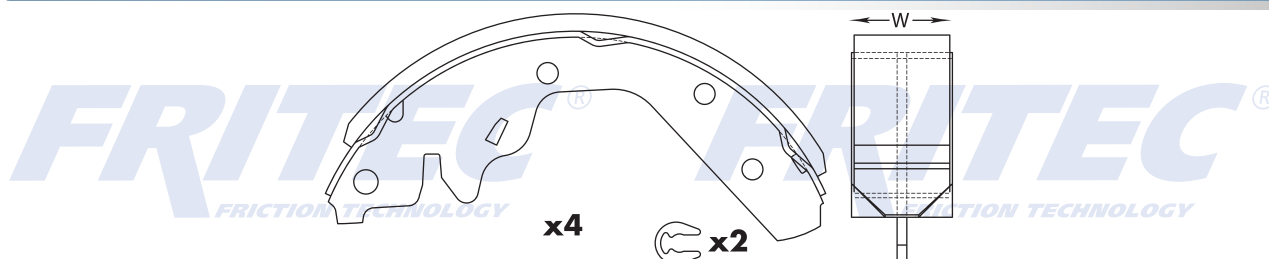

43

DIMENSIONES Ø= 8.000" (203.0 mm) W= 1.420" (36.0 mm)

1479-ZV S696

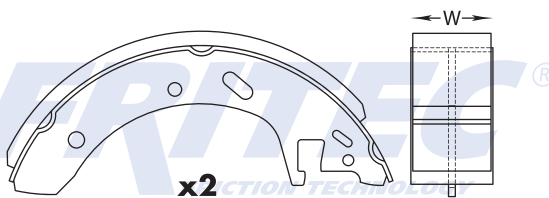
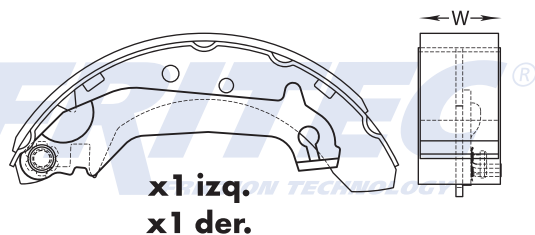

44

DIMENSIONES Ø= 7.870" (200.0 mm) W= 1.280" (32.5 mm)

1481-ZV S698

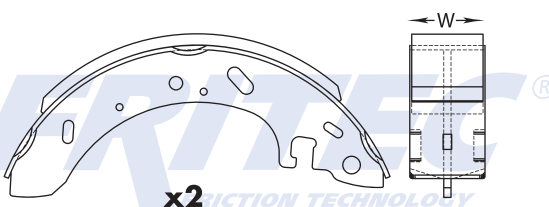
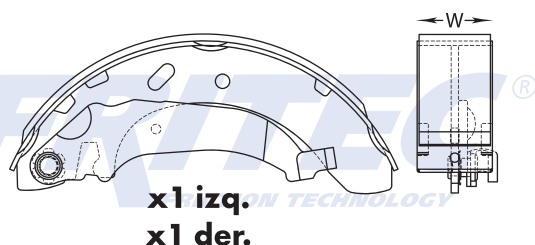

45

1481-Z1V S716

DIMENSIONES

Ø= 7.870" (200.0 mm)

W= 1.280" (32.5 mm)

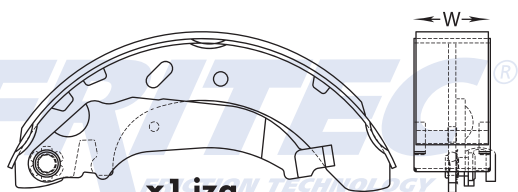

x1 izq.
x1 der.

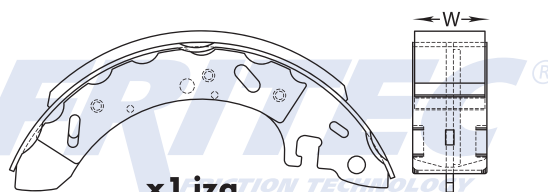

x1 izq.
x1 der.

46

1482-ZV S699

DIMENSIONES

Ø= 12.600" (320.0 mm)

W= 4.020" (102.1 mm)

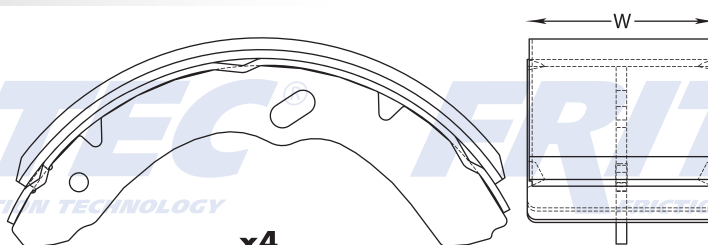

x4

47

1484-ZV S701

DIMENSIONES

Ø= 7.240" (184.0 mm)

W= 1.180" (30.0 mm)

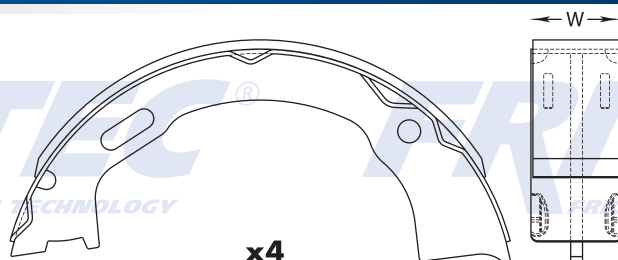

x4

48

1484-ZV S745

DIMENSIONES

Ø= 7.240" (184.0 mm)

W= 1.180" (30.0 mm)

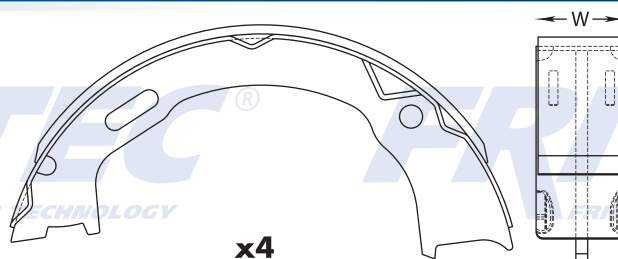

x4

49

DIMENSIONES $\varnothing = 9.840''$ (250.0 mm) $W = 2.170''$ (55.0 mm)

1485TT-ZV S703

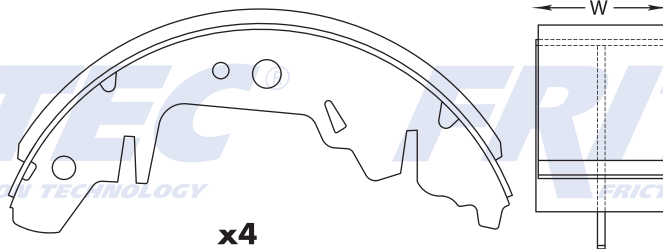

x4

50

DIMENSIONES $\varnothing = 9.840''$ (250.0 mm) $W = 2.170''$ (55.0 mm)

1485ATT-Z1V S714

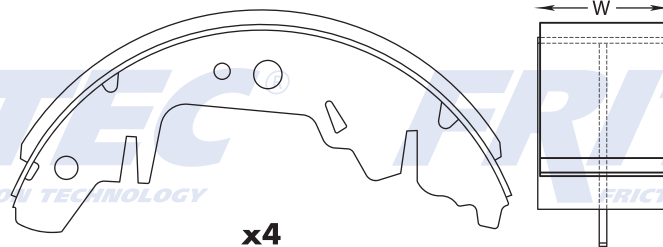

x4

51

DIMENSIONES $\varnothing = 8.000''$ (203.2 mm) $W = 1.430''$ (36.3 mm)

1495-Z1V S808

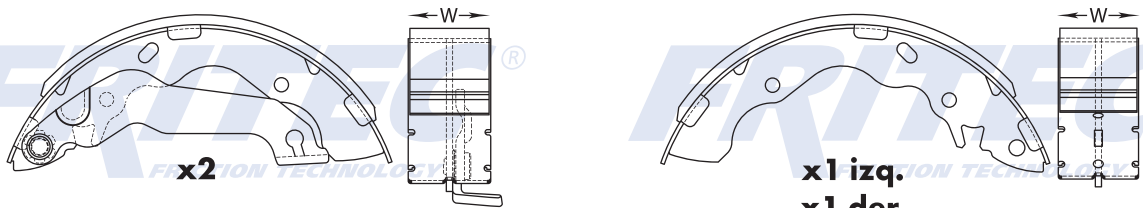

x2

x1 izq.
x1 der.

52

DIMENSIONES $\varnothing = 8.860''$ (225.0 mm) $W = 1.740''$ (44.2 mm)

1496-ZV S720

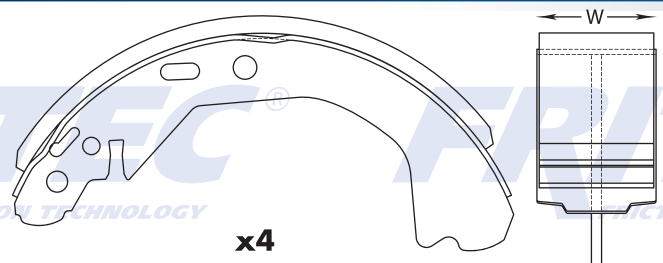

x4

53

14Y8-ZV FT032

DIMENSIONES

Ø= 7.060" (179.4 mm)

W= 1.630" (41.4 mm)

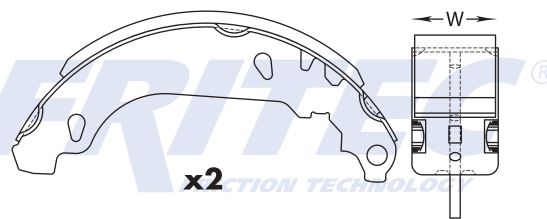
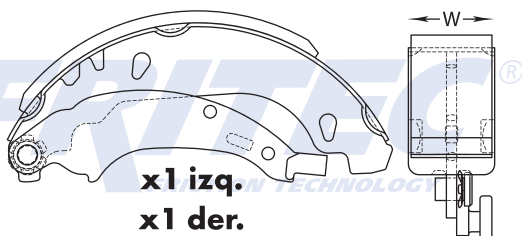

54

1500-ZV S780

DIMENSIONES

Ø= 9.840" (250.0 mm)

W= 1.780" (45.2 mm)

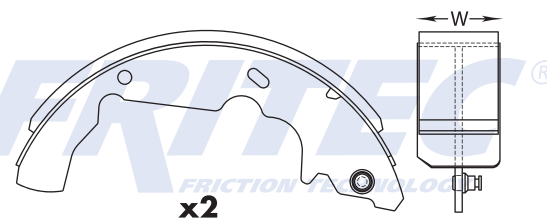
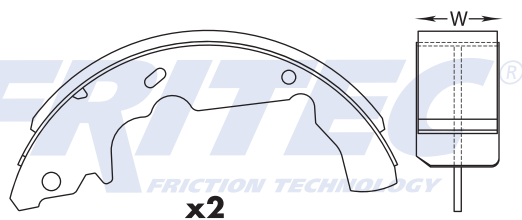

55

1504-ZV S736

DIMENSIONES

Ø= 9.000" (228.6 mm)

W= 1.690" (43.0 mm)

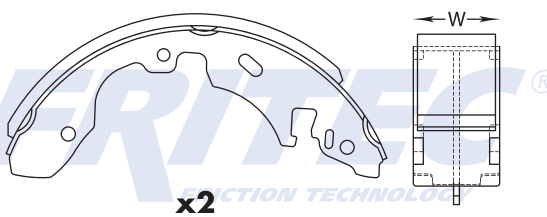
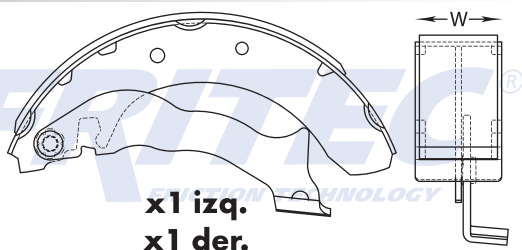

56

1506-ZV S738

DIMENSIONES

Ø= 8.660" (220.0 mm)

W= 1.560" (39.6 mm)

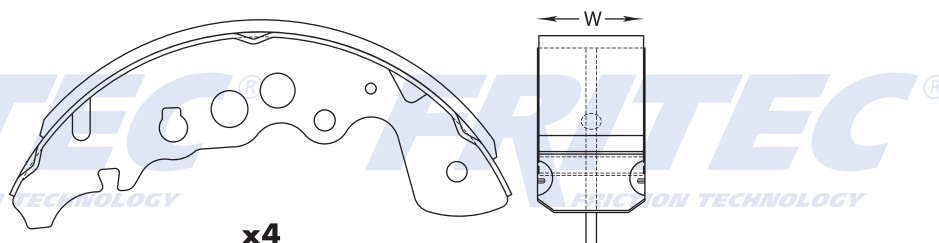

57

DIMENSIONES $\varnothing = 8.000''$ (203.2 mm) W= 1.440'' (36.6 mm)

1513-ZV S747

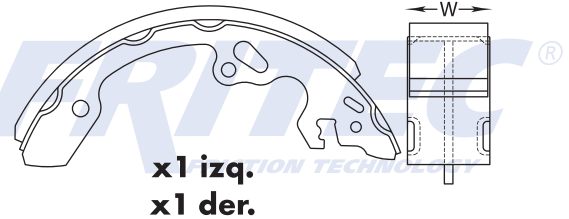
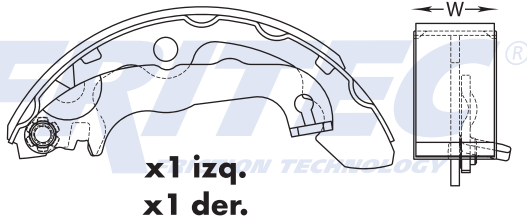

58

DIMENSIONES $\varnothing = 7.870''$ (200.0 mm) W= 1.180'' (30.0 mm)

1515-ZV S750

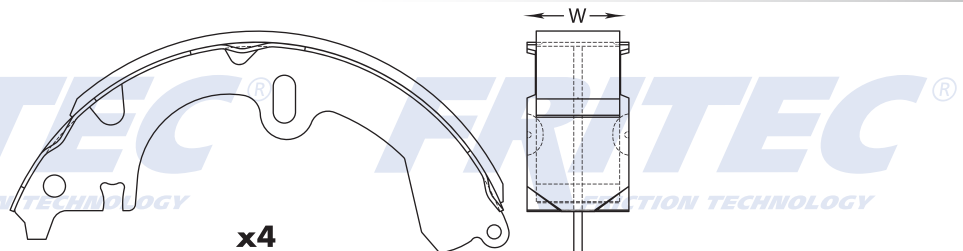

59

DIMENSIONES $\varnothing = 7.870''$ (200.0 mm) W= 1.240'' (31.5 mm)

1515-Z2V S801

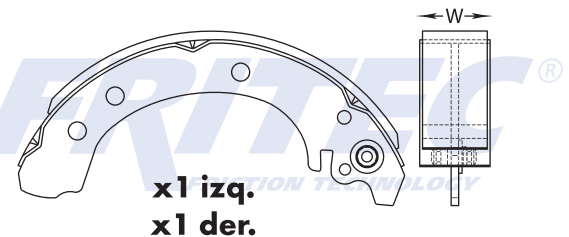
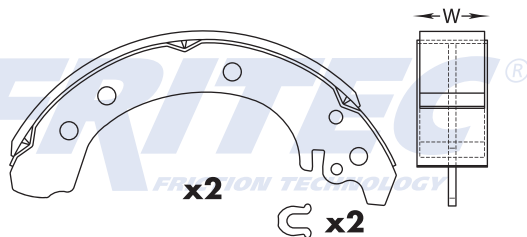

60

DIMENSIONES $\varnothing = 7.870''$ (200.0 mm) W= 1.180'' (30.0 mm)

1515-Z1V S832

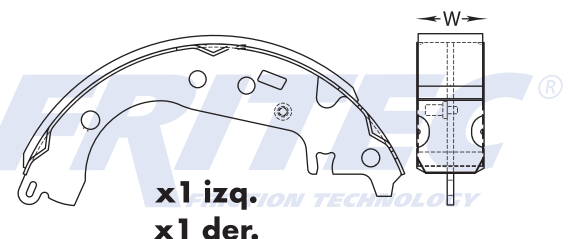
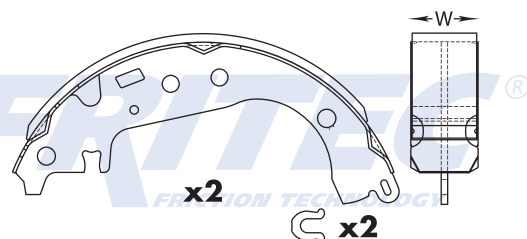

61

1516-ZV S751

DIMENSIONES

Ø= 9.060" (230.0 mm)

W= 1.610" (40.8 mm)

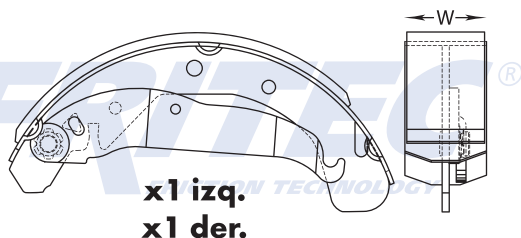

62

1517-ZV S752

DIMENSIONES

Ø= 9.000" (228.6 mm)

W= 1.180" (30.0 mm)

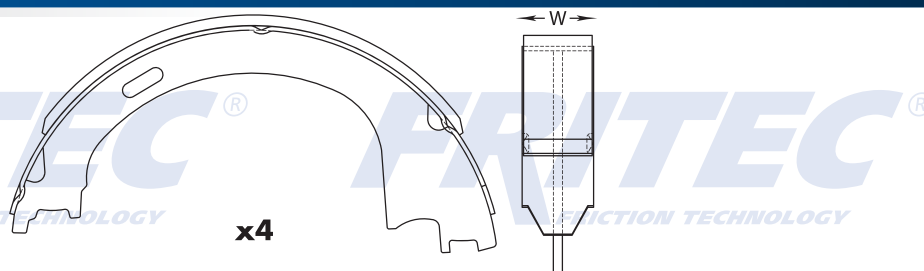

63

1524-ZV S760

DIMENSIONES

Ø= 9.000" (228.6 mm)

W= 1.630" (41.5 mm)

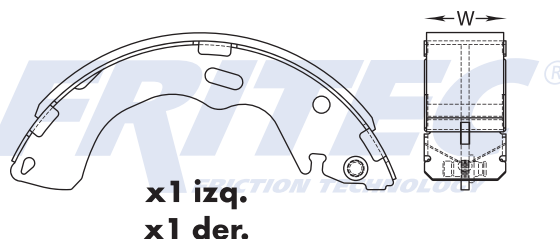
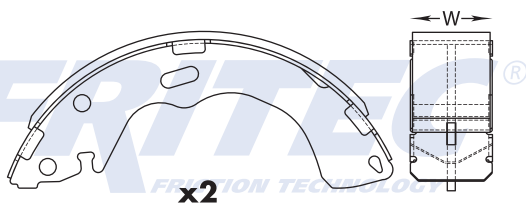

64

1525-ZIV S762

DIMENSIONES

Ø= 8.000" (203.2 mm)

W= 1.370" (34.8 mm)

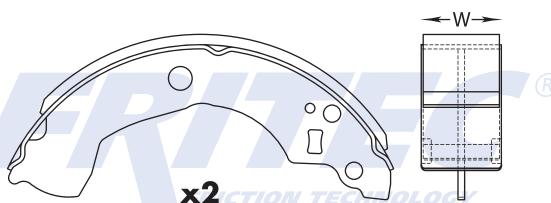
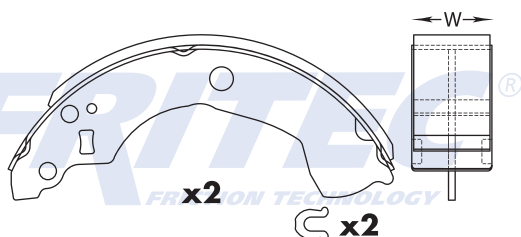

65

DIMENSIONES $\varnothing = 8.000''$ (203.2 mm) $W = 1.370''$ (34.8 mm)

1525-ZV S779

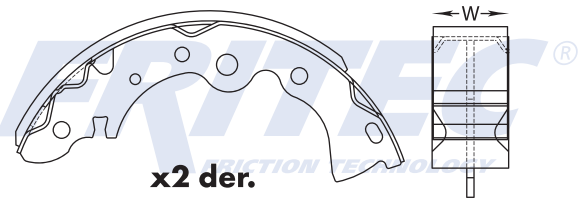
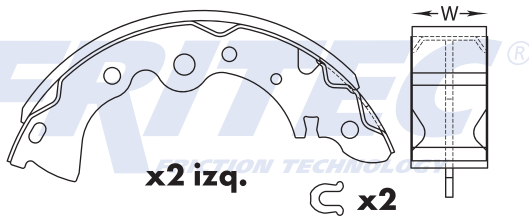

66

DIMENSIONES $\varnothing = 7.183''$ (182.4 mm) $W = 1.417''$ (36.0 mm)

1525-ZV S1034

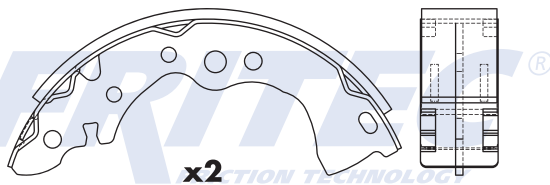

67

DIMENSIONES $\varnothing = 9.000''$ (228.6 mm) $W = 1.380''$ (35.0 mm)

1529-ZV S785

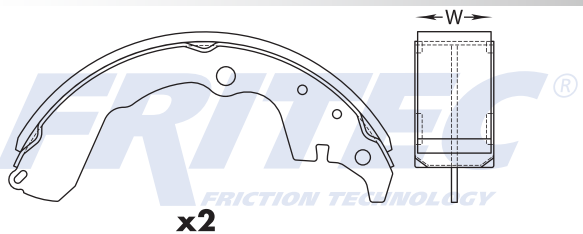
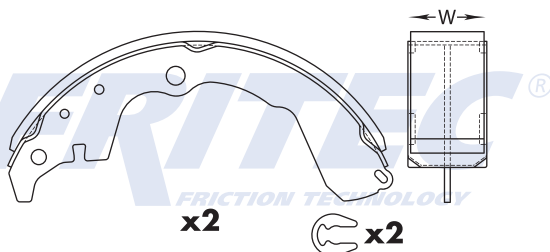

68

DIMENSIONES $\varnothing = 7.240''$ (183.9 mm) $W = 1.110''$ (28.2 mm)

1533-ZV S791

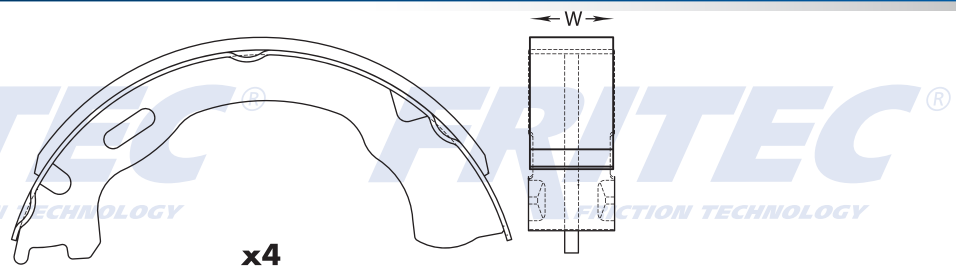

69

1535-ZV S795

DIMENSIONES Ø= 9.060" (230.1 mm) W= 1.600" (40.6 mm)

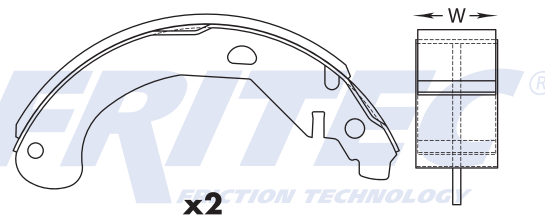
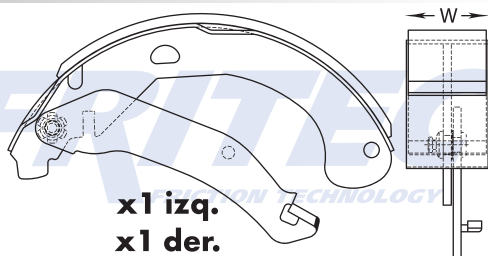

70

1540-ZV S800

DIMENSIONES Ø= 9.000" (228.6 mm) W= 1.660" (42.2 mm)

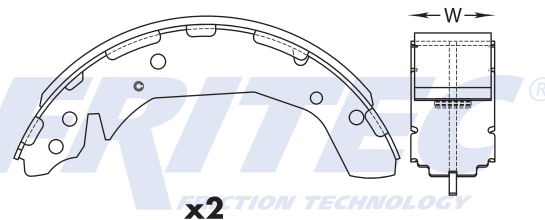
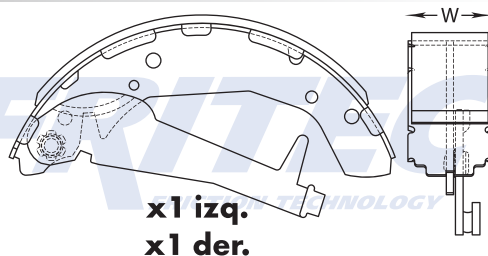

71

1542-ZV S810

DIMENSIONES Ø= 9.000" (228.6 mm) W= 1.650" (42.0 mm)

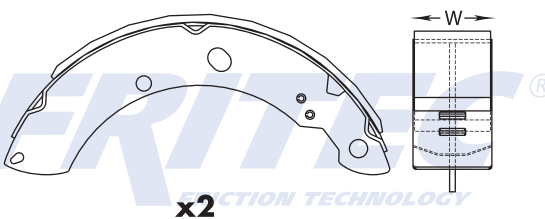
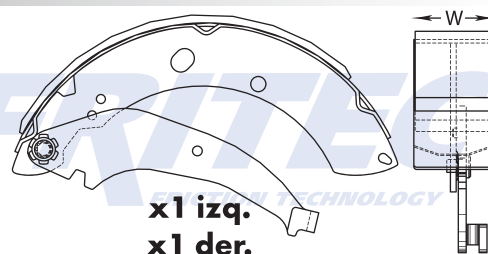

72

1543-ZV S803

DIMENSIONES Ø= 8.114" (206.1 mm) W= 11.220" (31.0 mm)

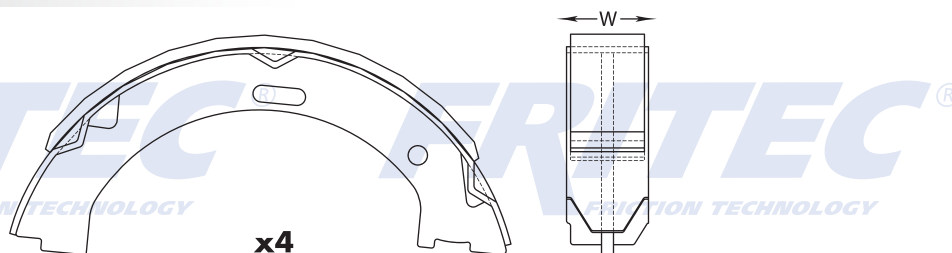

73

DIMENSIONES $\varnothing = 7.850''$ (199.5 mm) $W = 1.378''$ (35.0 mm)

1547-ZV S814

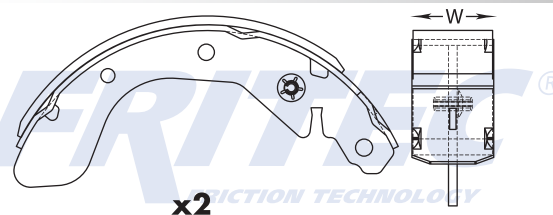
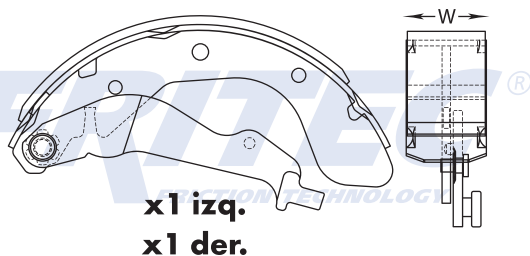

74

DIMENSIONES $\varnothing = 11.660''$ (296.2 mm) $W = 1.750''$ (44.5 mm)

1548-ZV S815

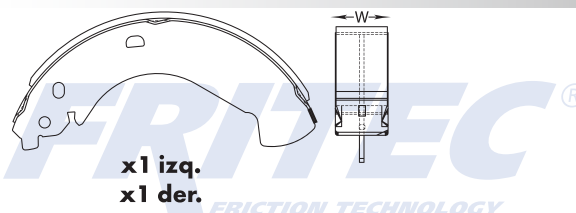
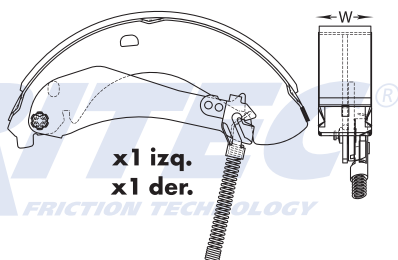

75

DIMENSIONES $\varnothing = 11.820''$ (300.0 mm) $W = 2.980''$ (75.7 mm)

1556K-ZV S824

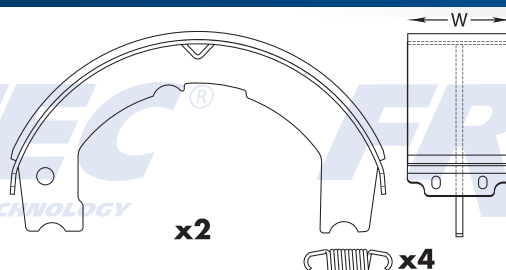

x4

76

DIMENSIONES $\varnothing = 8.110''$ (206.0 mm) $W = 1.730''$ (44.0 mm)

1581-ZV S852

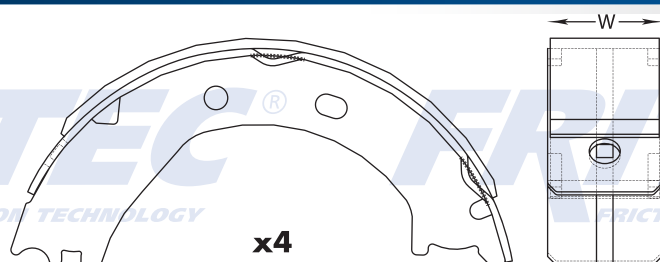

77

1582-ZV FT051

DIMENSIONES Ø= 11.656" (296.0 mm) W= 2.420" (61.5 mm)

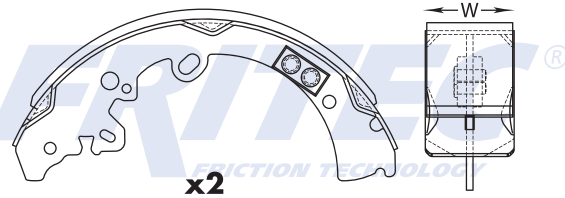
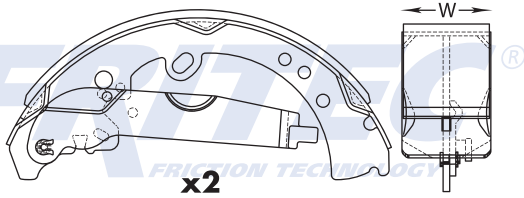

78

1582-Z1V S922

DIMENSIONES Ø= 11.600" (294.6 mm) W= 2.290" (58.5 mm)

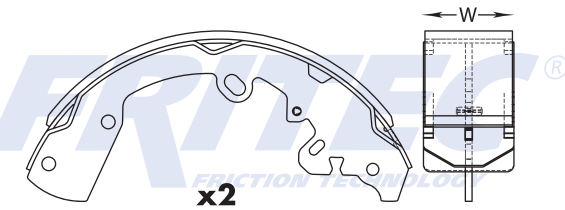
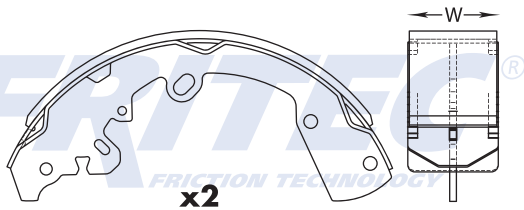

79

1583-ZV S855

DIMENSIONES Ø= 11.680" (296.7 mm) W= 2.340" (59.4 mm)

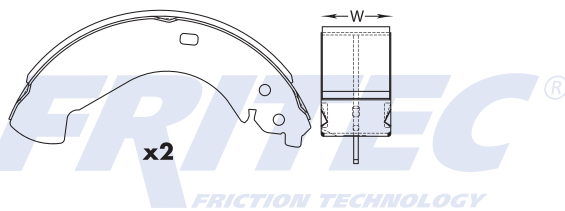
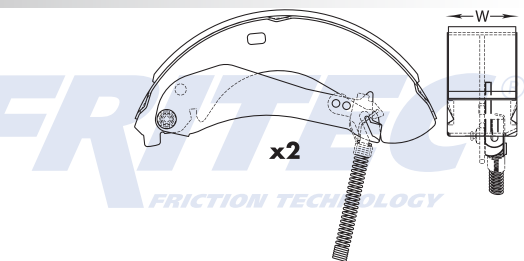

80

1595-ZV S938

DIMENSIONES Ø= 7.090" (180.0 mm) W= 0.980" (24.8 mm)

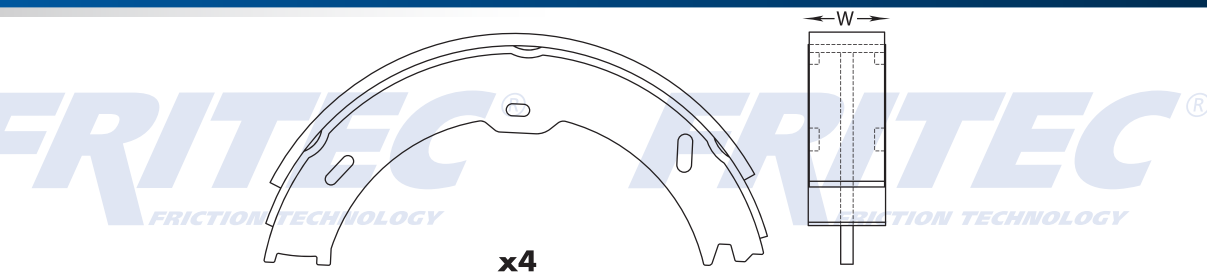

81

DIMENSIONES $\varnothing = 11.626''$ (295.3 mm) $W = 2.420''$ (61.5 mm)

1681-ZV S1012

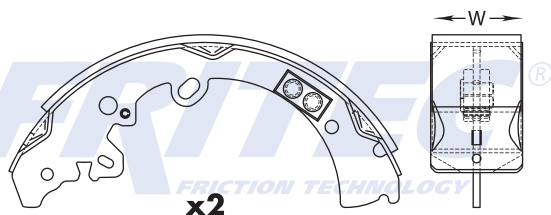

82

DIMENSIONES $\varnothing = 11.525''$ (292.7 mm) $W = 2.000''$ (50.8 mm)

1685-ZV S1016

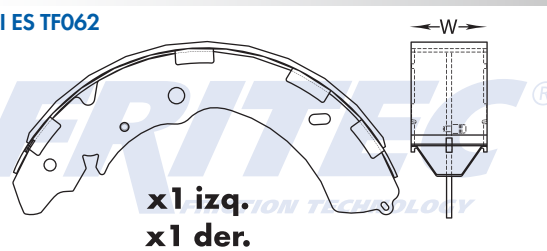
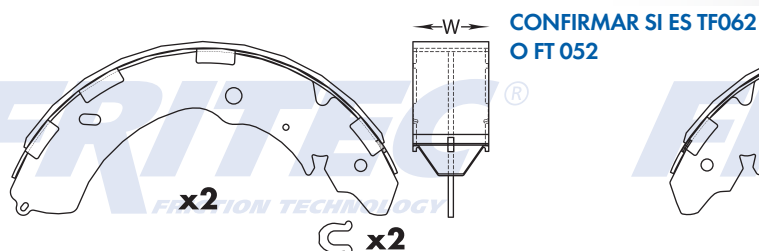

83

DIMENSIONES $\varnothing = 9.000''$ (228.6 mm) $W = 1.650''$ (42.0 mm)

15Y2-ZV S810

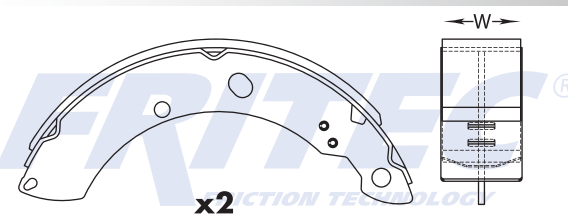
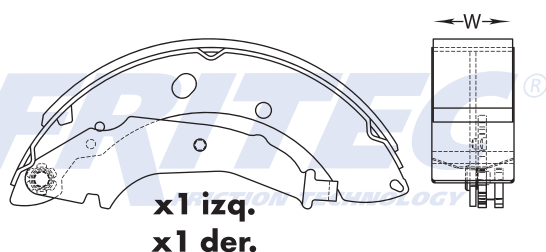

84

DIMENSIONES $\varnothing = 7.870''$ (200.0 mm) $W = 1.417''$ (36.0 mm)

1480-ZV S814

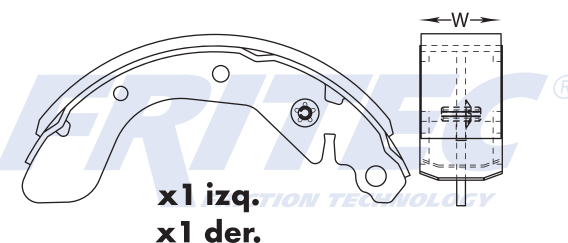
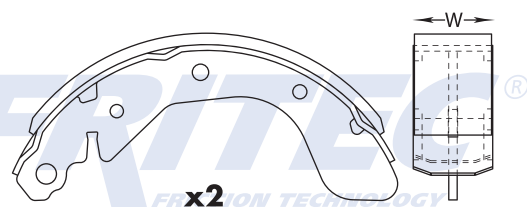

85

1616-ZV S910

DIMENSIONES $\varnothing = 7.980''$ (202.7 mm) **W = 1.180''** (30.0 mm)

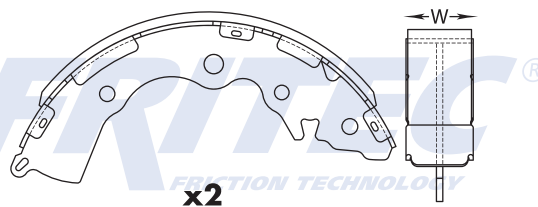
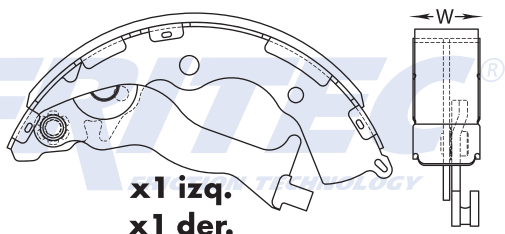

86

1616-Z1V S1021

DIMENSIONES $\varnothing = 7.980''$ (202.7 mm) **W = 1.220''** (31.0 mm)

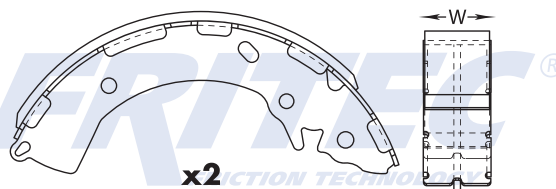
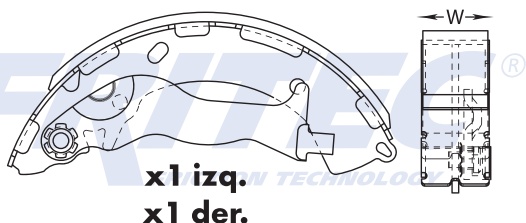

87

1618-ZV S913

DIMENSIONES $\varnothing = 7.890''$ (200.4 mm) **W = 1.220''** (31.0 mm)

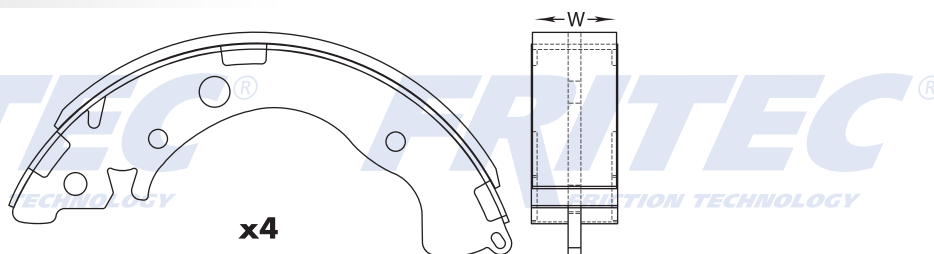

88

1621-ZV S917

DIMENSIONES $\varnothing = 7.812''$ (198.4 mm) **W = 1.265''** (32.1 mm)

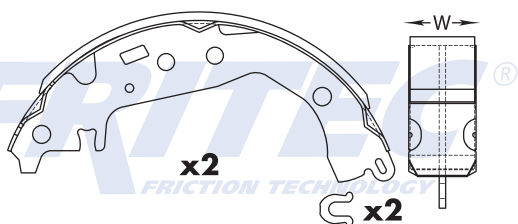

89

DIMENSIONES $\varnothing = 8.980''$ (228.0 mm) $W = 1.628''$ (41.3 mm)

1623-ZV S921

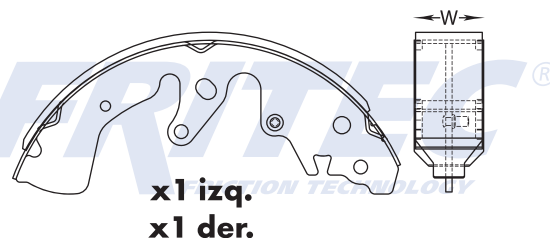
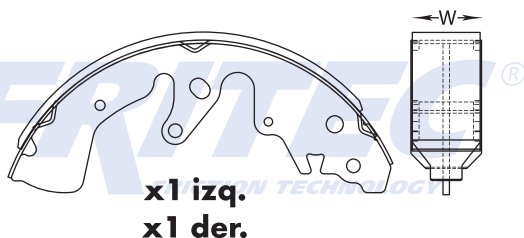

90

DIMENSIONES $\varnothing = 8.060''$ (204.7 mm) $W = 1.180''$ (30.0 mm)

1624-ZV S924

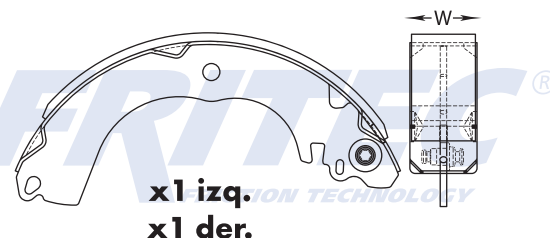
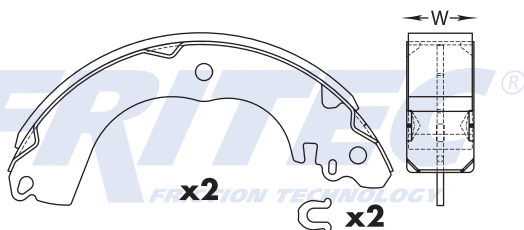

91

DIMENSIONES $\varnothing = 9.950''$ (252.7 mm) $W = 2.165''$ (55.0 mm)

1629-ZV S936

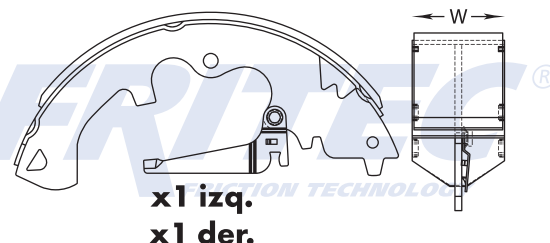
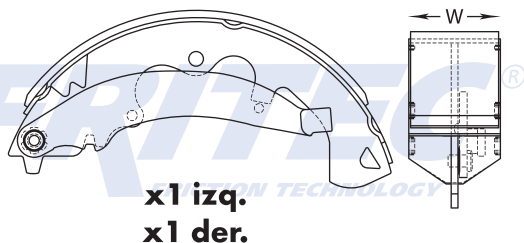

92

DIMENSIONES $\varnothing = 7.560''$ (192.0 mm) $W = 1.265''$ (32.1 mm)

162X-ZV FT122

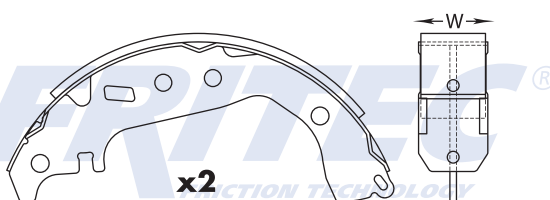
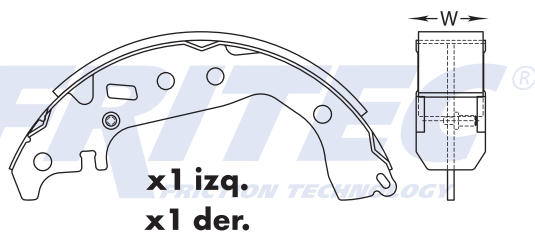

93

1632-ZV S940

DIMENSIONES

Ø= 6.330" (160.7 mm)

W= 1.660" (42.2 mm)

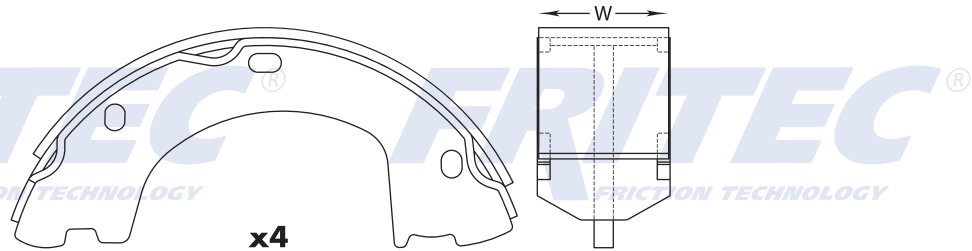

94

1635-ZV S945

DIMENSIONES

Ø= 9.078" (230.5 mm)

W= 1.458" (37.0 mm)



95

1641-ZV S954

DIMENSIONES

Ø= 8.660" (220.0 mm)

W= 1.430" (36.3 mm)

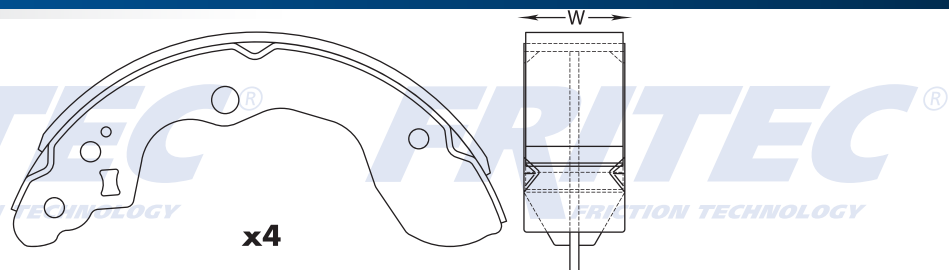

96

1643-ZV S959

DIMENSIONES

Ø= 11.552" (293.4 mm)

W= 1.850" (47.0 mm)

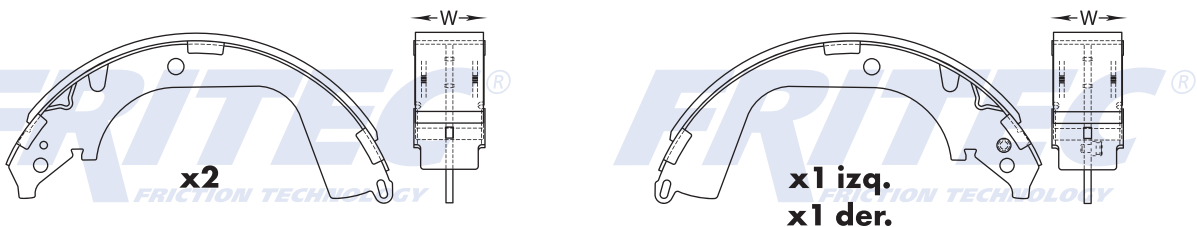

97

DIMENSIONES $\varnothing = 11.552''$ (293.4 mm) W= 2.440'' (62.0 mm)

1644-ZV S960

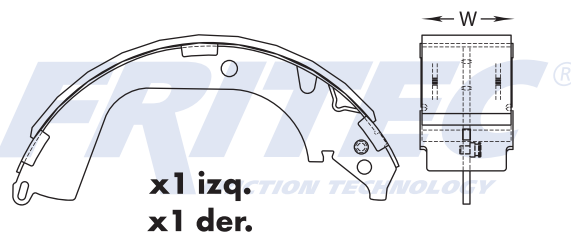
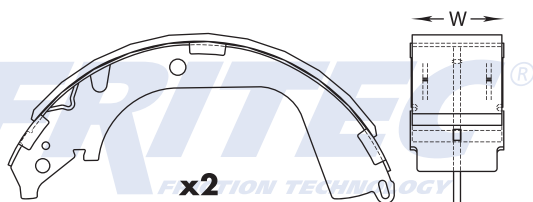

98

DIMENSIONES $\varnothing = 7.300''$ (185.4 mm) W= 2.000'' (51.0 mm)

1654-ZV S979

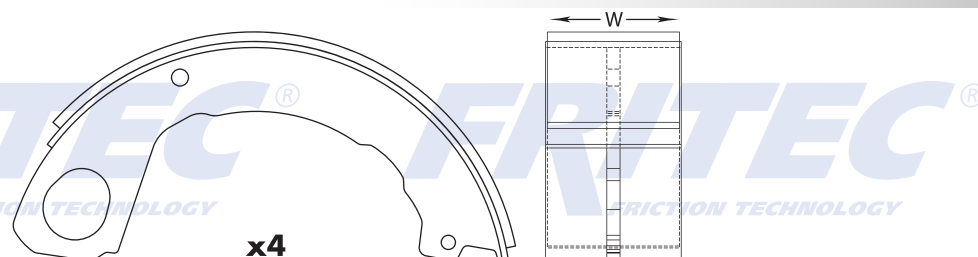

99

DIMENSIONES $\varnothing = 10.000''$ (254.0 mm) W= 1.560'' (39.6 mm)

1663-ZV S992

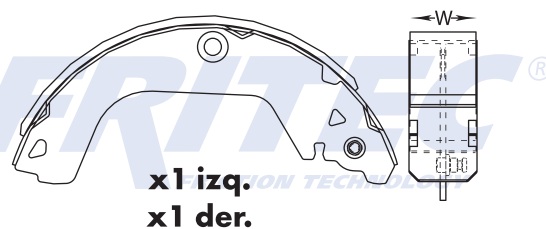
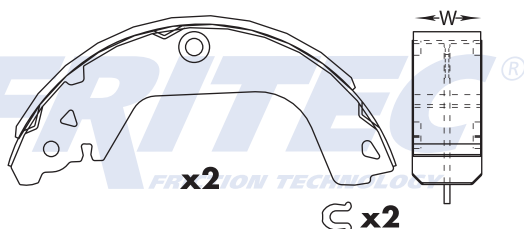

100

DIMENSIONES $\varnothing = 11.560''$ (293.7 mm) W= 2.180'' (55.4 mm)

1667-ZV S996

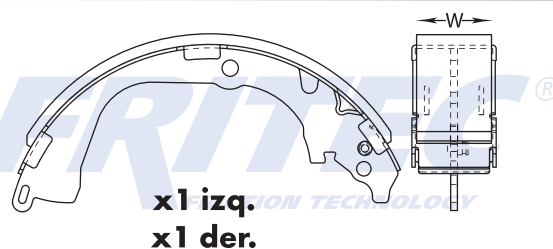
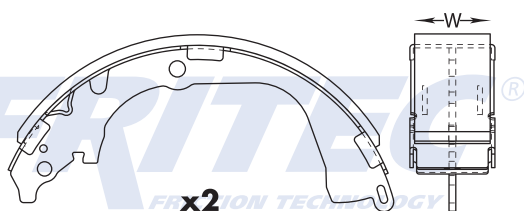

101

1674-ZV S1004

DIMENSIONES Ø= 8.040" (204.1 mm) W= 1.640" (41.5 mm)

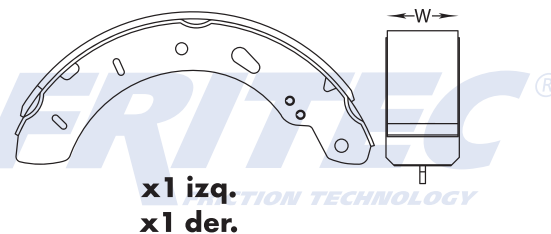
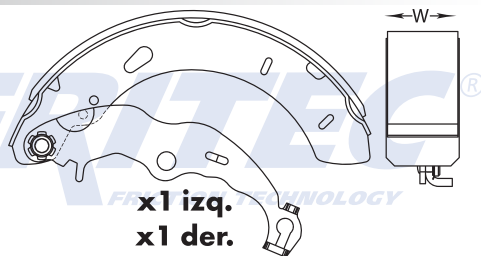

102

1680-ZV S1011

DIMENSIONES Ø= 9.060" (230.1 mm) W= 1.560" (41.1 mm)

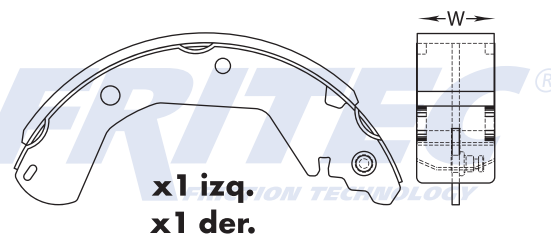
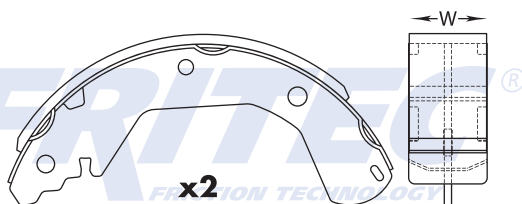

103

1689-ZV S1020

DIMENSIONES Ø= 8.054" (204.6 mm) W= 1.496" (38.0 mm)

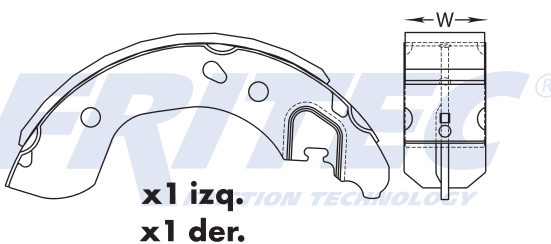
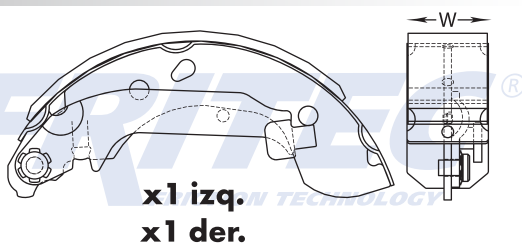

104

1694-ZV S1039

DIMENSIONES Ø= 8.960" (227.6 mm) W= 1.560" (39.6 mm)

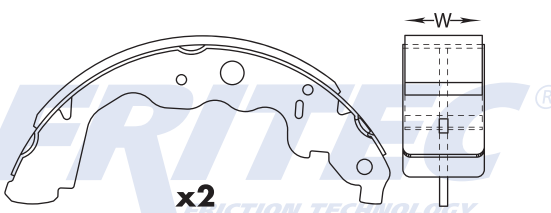
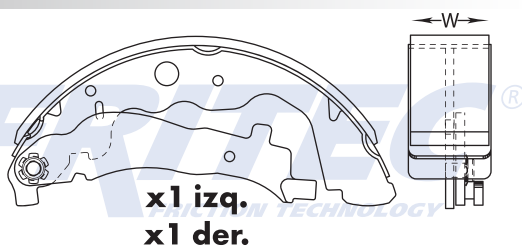

105

DIMENSIONES Ø= 8.364" (212.5 mm) W= 1.470" (37.0 mm)

1695-ZV S1029

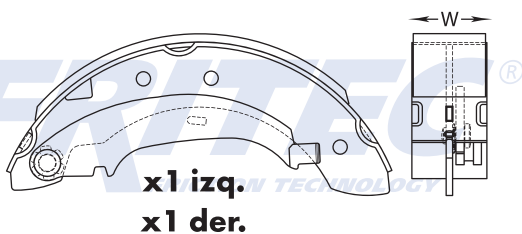

106

DIMENSIONES Ø= 9.038" (229.6 mm) W= 1.570" (39.9 mm)

1713-ZV S1054

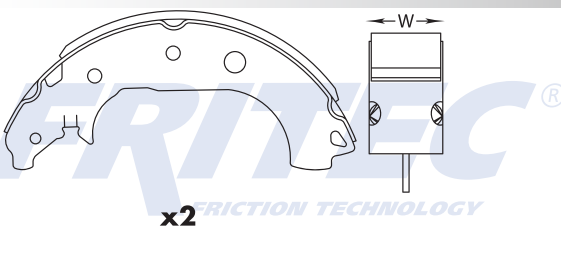
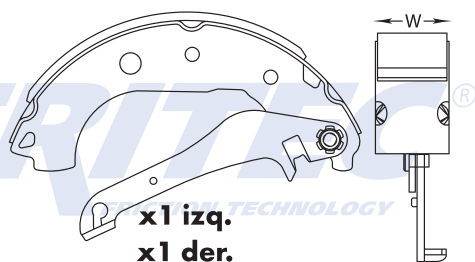

107

DIMENSIONES Ø= 11.030" (280.1 mm) W= 1.668" (42.8 mm)

1708-ZV S1046

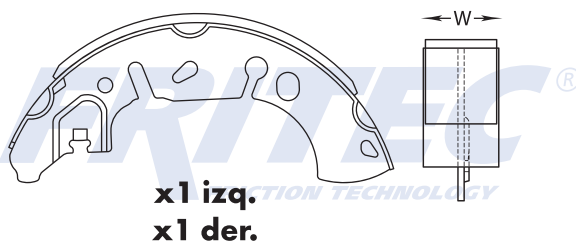
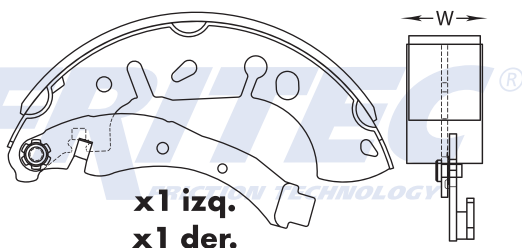

108

DIMENSIONES Ø= 11.560" (293.6 mm) W= 2.190" (55.6 mm)

1709-ZV S1049

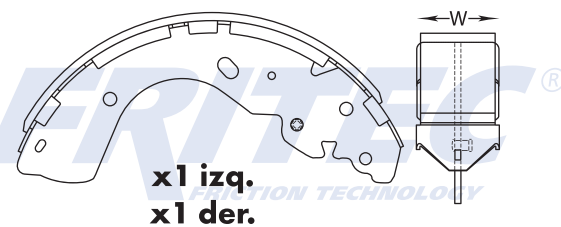
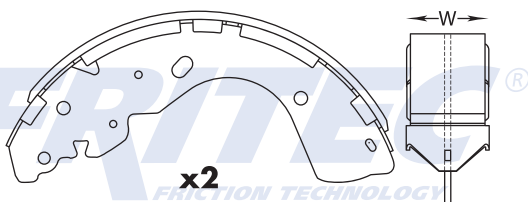

109

1717-ZV S1059

DIMENSIONES

Ø= 7.110" (180.6 mm)

W= 1.160" (30.0 mm)

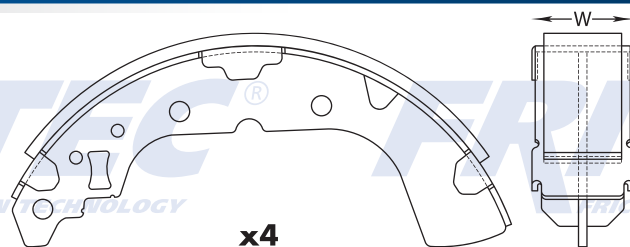

x4

110

1722-ZV S1067

DIMENSIONES

Ø= 7.300" (185.4 mm)

W= 1.655" (42.0 mm)

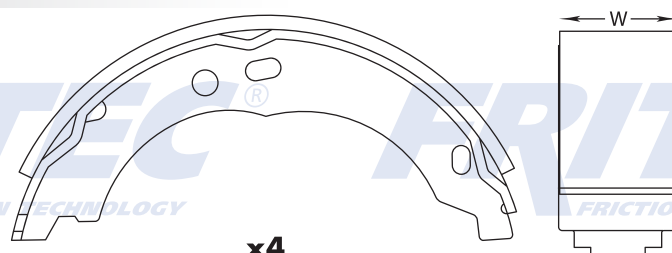

x4

111

1734-ZV S1085

DIMENSIONES

Ø= 8.000" (203.2 mm)

W= 1.500" (38.1 mm)

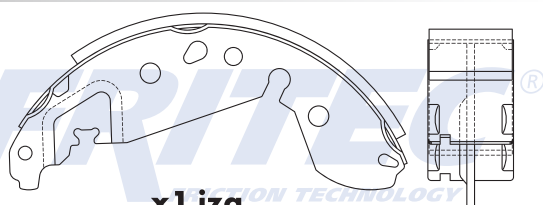

x1 izq.
x1 der.

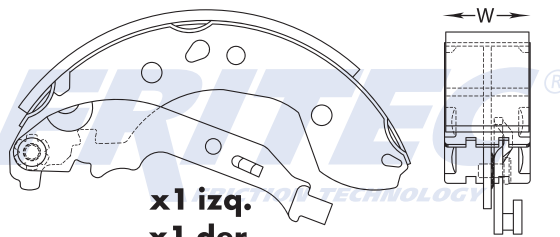

x1 izq.
x1 der.

112

1X24-ZV FT009

DIMENSIONES

Ø= 10.000" (254.0 mm)

W= 1.970" (50.0 mm)

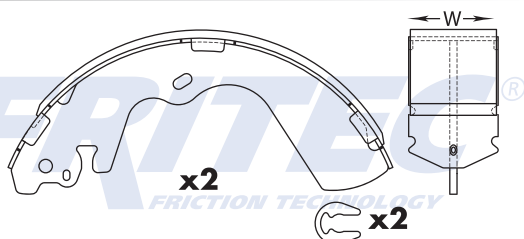

x2

x2

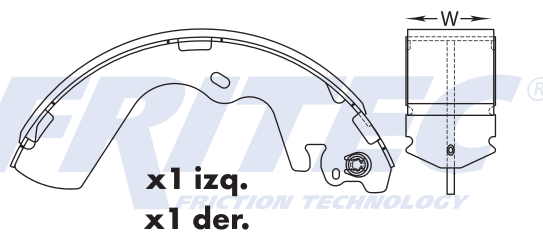

x1 izq.
x1 der.

113

DIMENSIONES $\varnothing = 10.262''$ (260.6 mm) $W = 2.000''$ (50.8 mm)

1740-ZV S1094

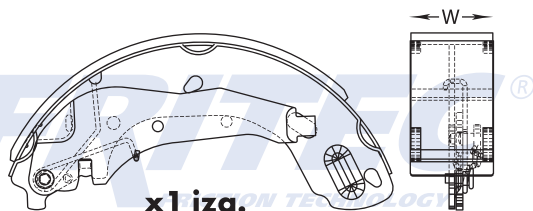

x1 izq.
x1 der.

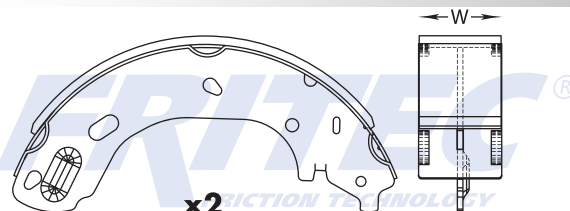

x2

114

DIMENSIONES $\varnothing = 10.186''$ (258.7 mm) $W = 2.020''$ (51.3 mm)

1399-Z1V S1026

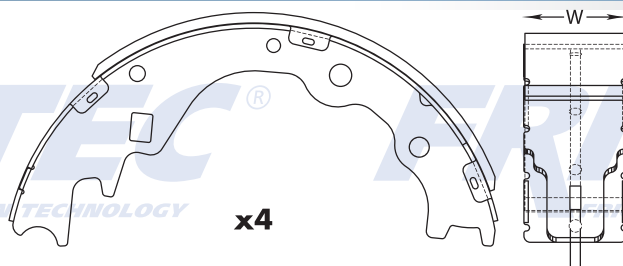

x4

115

DIMENSIONES $\varnothing = 10.636''$ (270.2 mm) $W = 2.190''$ (55.2 mm)

1X36-ZV FT117

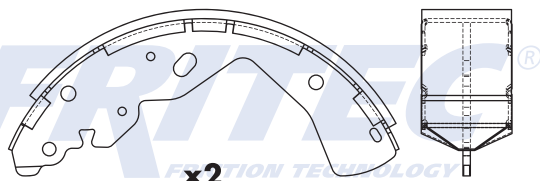

x2

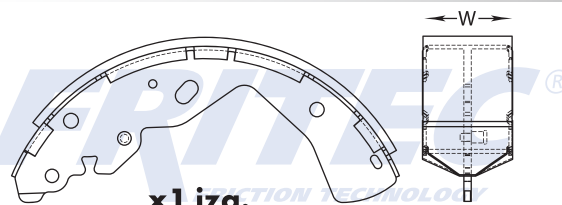

x1 izq.
x1 der.

116

DIMENSIONES $\varnothing = 11.625''$ (295.3 mm) $W = 2.105''$ (53.5 mm)

1X44-ZV FT054

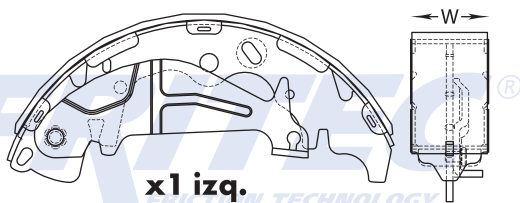

x1 izq.
x1 der.

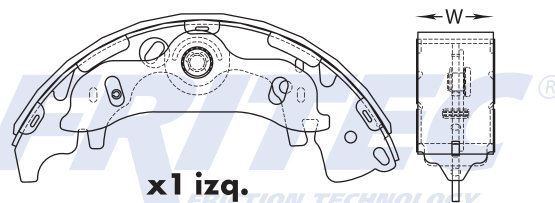

x1 izq.
x1 der.

117

1X50-ZV FT121

DIMENSIONES

Ø= 7.640" (194.0 mm)

W= 1.500" (38.1 mm)

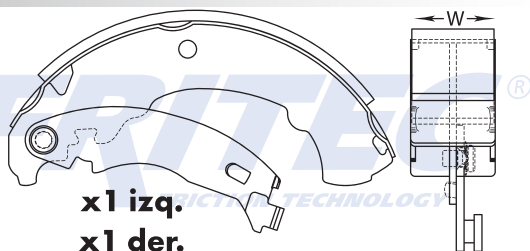

x1 izq.
x1 der.

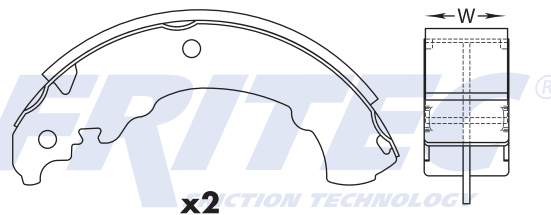

x2

118

1X81-ZV FT024

DIMENSIONES

Ø= 7.110" (180.6 mm)

W= 1.260" (32.0 mm)

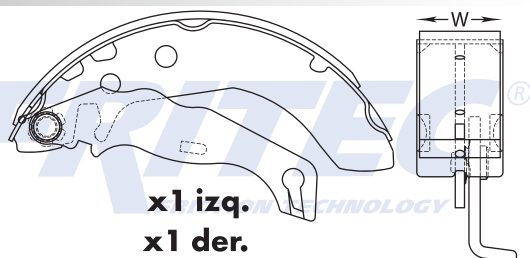

x1 izq.
x1 der.

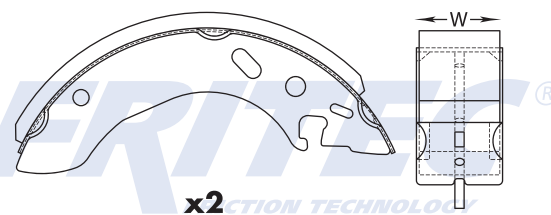

x2

119

1X89-ZV FT080

DIMENSIONES

Ø= 6.107" (155.1 mm)

W= 1.225" (31.1 mm)

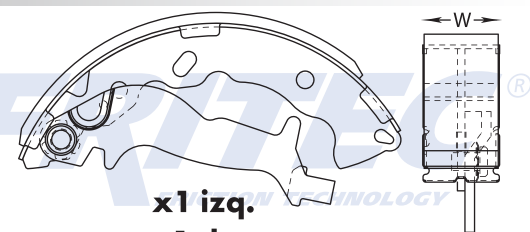

x1 izq.
x1 der.

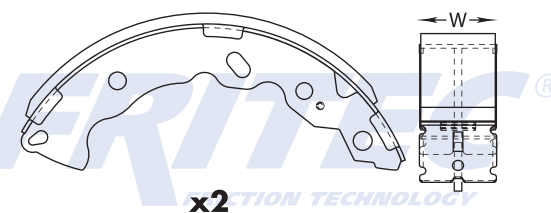

x2

120

1Y08-ZV FT025

DIMENSIONES

Ø= 7.850" (199.5 mm)

W= 1.378" (35.0 mm)

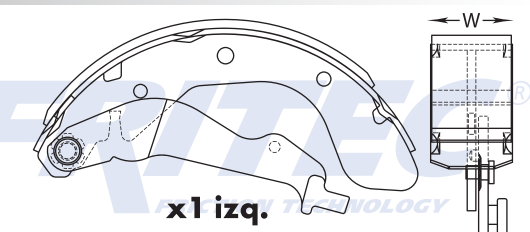

x1 izq.
x1 der.

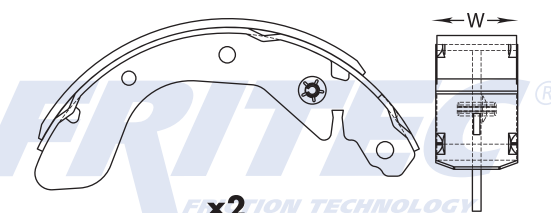

x2

121

DIMENSIONES Ø= 8.060" (204.7 mm) W= 1.457" (37.0 mm)

1Y15-ZV FT034

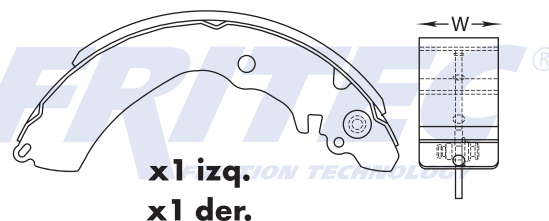
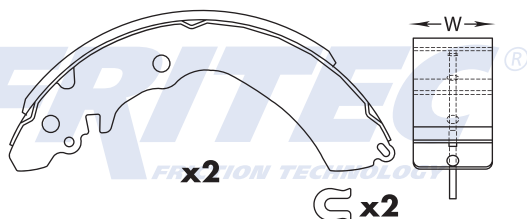

122

DIMENSIONES Ø= 7.060" (179.4 mm) W= 1.181" (30.0 mm)

1Y16-ZV FT035

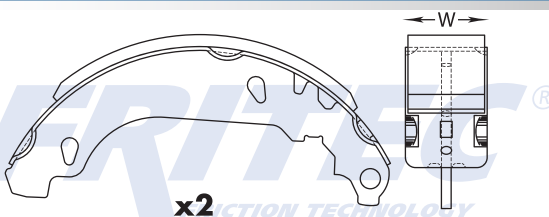

123

DIMENSIONES Ø= 8.994" (228.5 mm) W= 1.594" (40.5 mm)

1Y19-ZV FT040

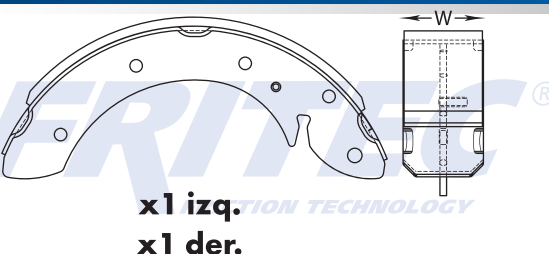
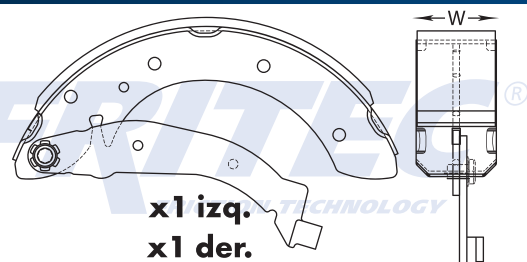

124

DIMENSIONES Ø= 8.000" (203.2 mm) W= 1.457" (37.0 mm)

1Y20-ZV FT031

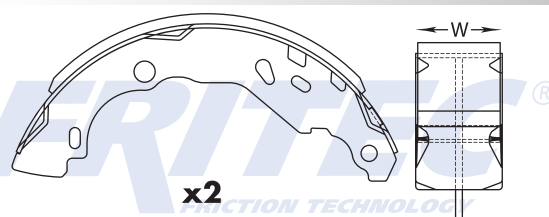
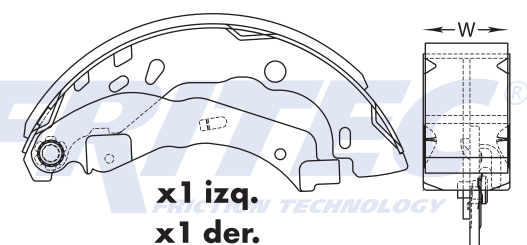

125

1Y21-ZV FT119

DIMENSIONES

Ø= 7.716" (196.0 mm)

W= 1.380" (35.0 mm)

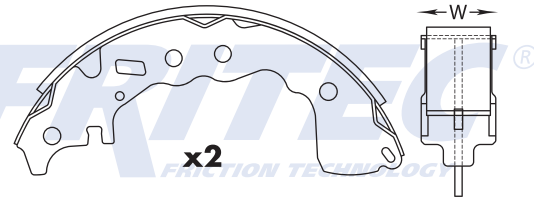
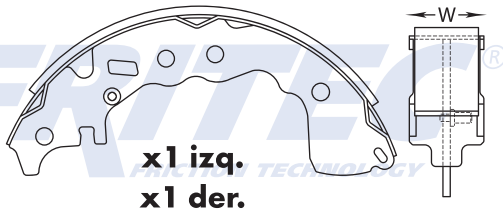

126

1Y22-ZV FT124

DIMENSIONES

Ø= 6.284" (159.6 mm)

W= 1.236" (31.4 mm)

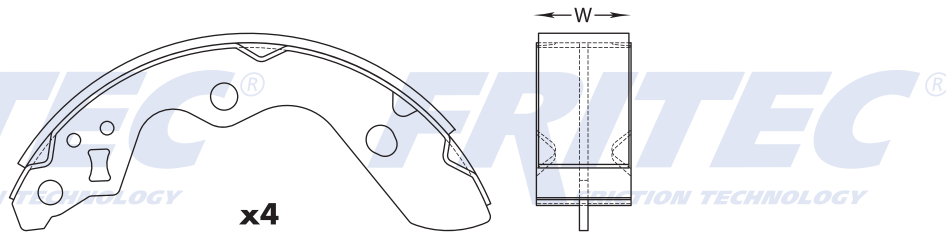

127

1Y25-ZV FT060

DIMENSIONES

Ø= 7.850" (199.3 mm)

W= 1.230" (31.2 mm)

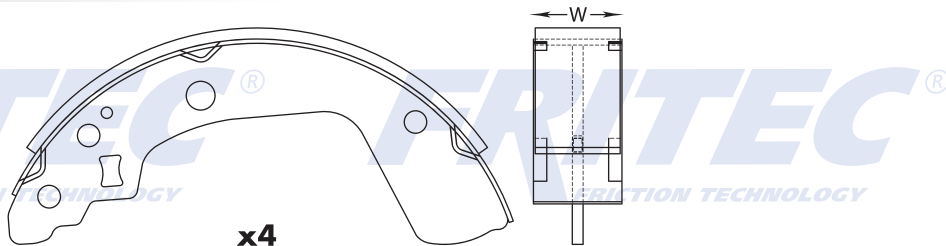

128

1Y28-ZV FT038

DIMENSIONES

Ø= 8.960" (227.6 mm)

W= 1.654" (42.0 mm)

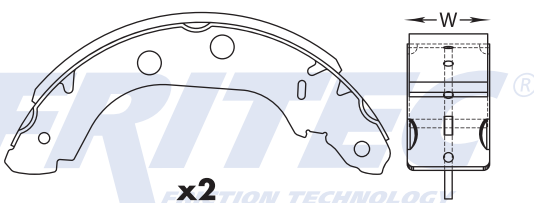
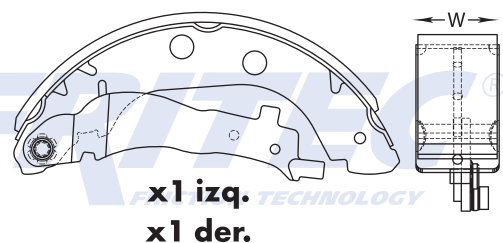

129

DIMENSIONES $\varnothing = 6.900''$ (175.3 mm) $W = 1.060''$ (26.9 mm)

1Y90-ZV FT115

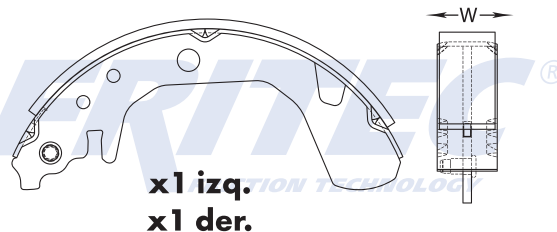
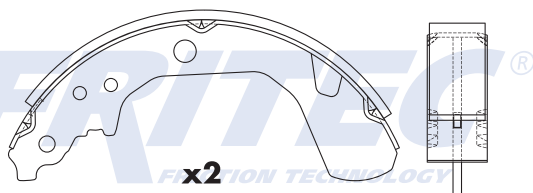

130

DIMENSIONES $\varnothing = 10.170''$ (258.3 mm) $W = 2.040''$ (51.8 mm)

1Y97-ZV S589

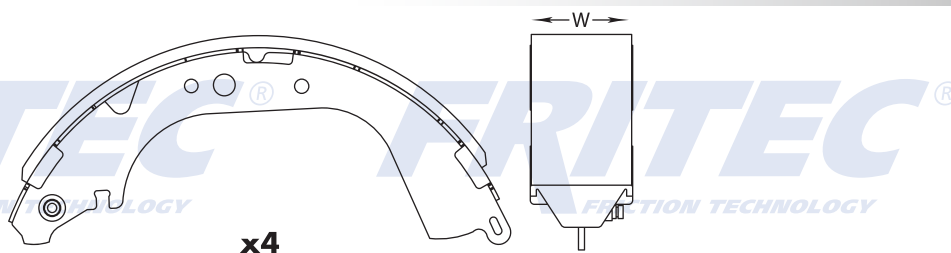

131

DIMENSIONES $\varnothing = 11.000''$ (279.4 mm) $W = 2.000''$ (50.8 mm)

2006-Z1V S280

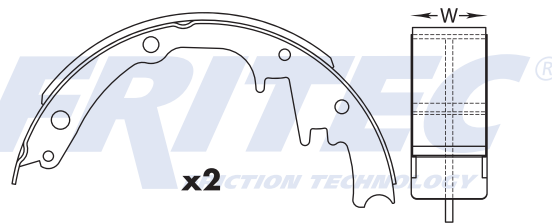
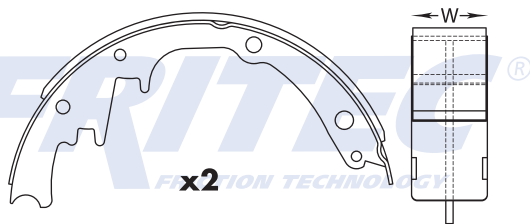

132

DIMENSIONES $\varnothing = 11.000''$ (279.4 mm) $W = 2.500''$ (63.5 mm)

2025-ZV S446

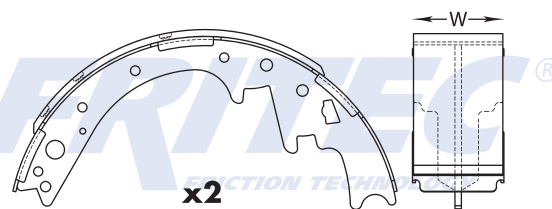
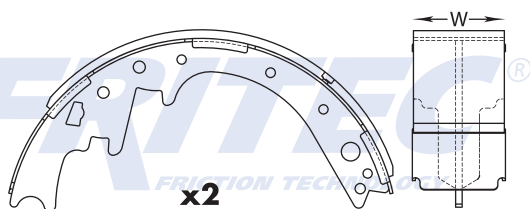

133

2042AT-Z1V 451

DIMENSIONES $\varnothing = 13.000''$ (330.2 mm) $W = 3.559''$ (90.0 mm)



134

2073T-ZR S473

DIMENSIONES $\varnothing = 11.160''$ (283.5 mm) $W = 2.750''$ (70.0 mm)

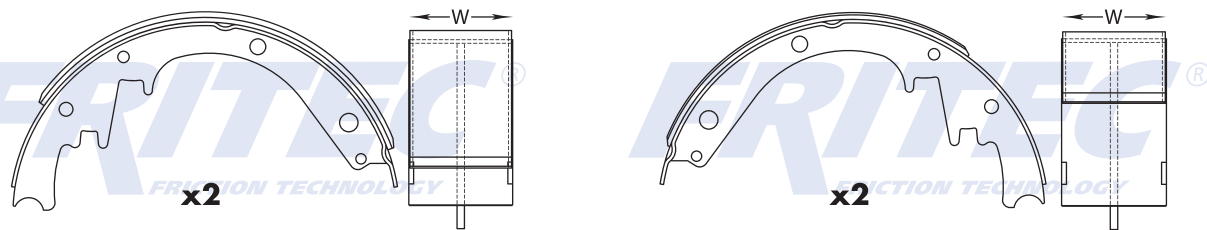

135

2079BK-ZV S824

DIMENSIONES $\varnothing = 12.000''$ (304.8 mm) $W = 3.000''$ (76.2 mm)

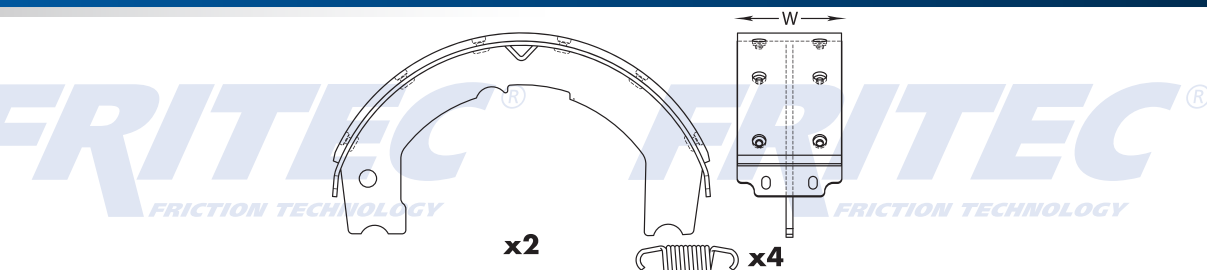

136

2080T-ZV S264

DIMENSIONES $\varnothing = 11.030''$ (280.0 mm) $W = 1.654''$ (42.0 mm)

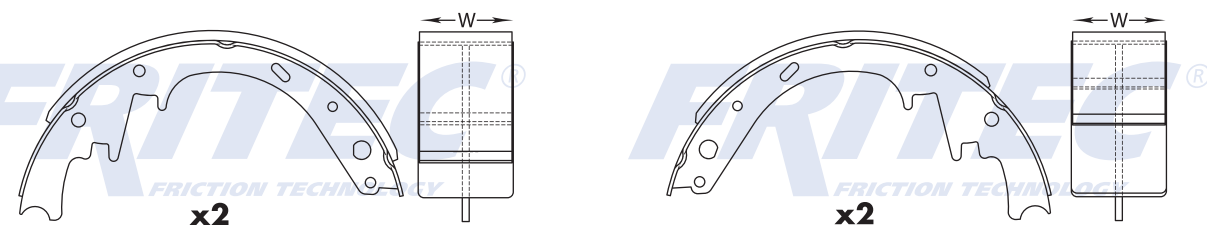

137

DIMENSIONES $\varnothing = 11.030''$ (280.0 mm) $W = 2.500''$ (63.5 mm)

2080TT-ZV S264

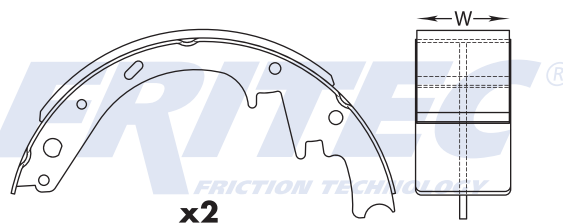
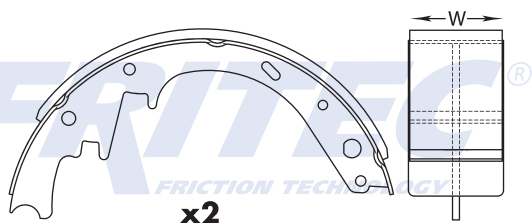

138

DIMENSIONES $\varnothing = 12.000''$ (304.8 mm) $W = 4.000''$ (101.6 mm)

2085K-ZR FT022

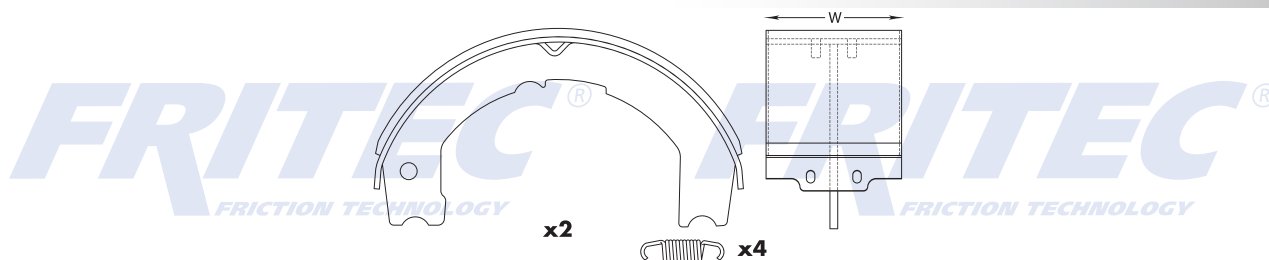

139

DIMENSIONES $\varnothing = 9.000''$ (228.6 mm) $W = 3.000''$ (76.2 mm)

2086K-ZR S646

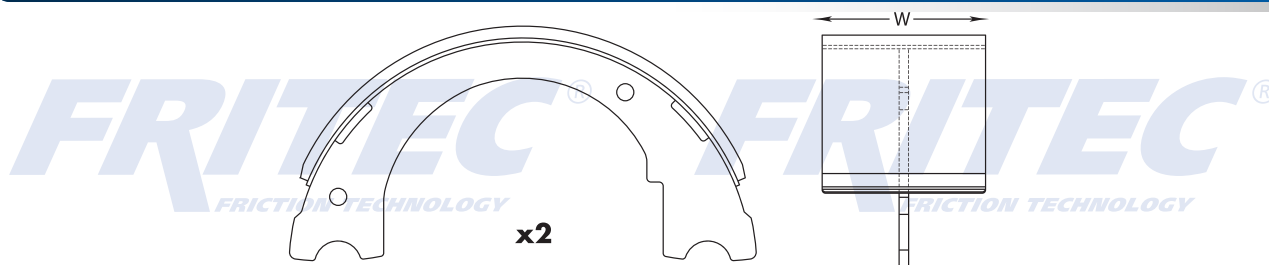

140

DIMENSIONES $\varnothing = 9.000''$ (228.6 mm) $W = 3.000''$ (76.2 mm)

2086K-ZR S647

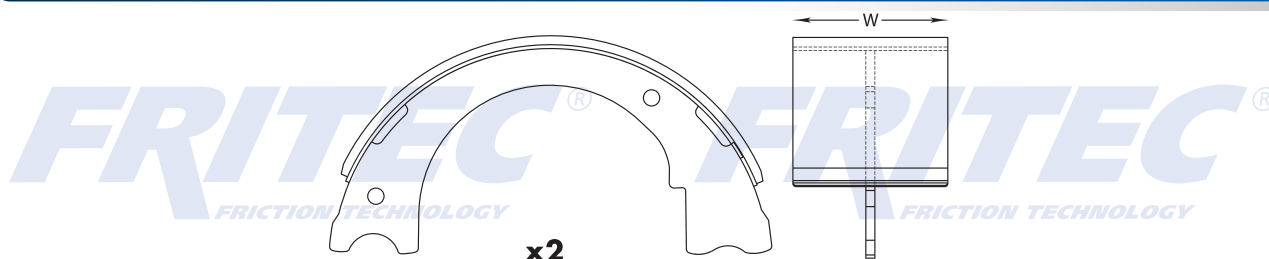

141

2089T-ZV S445

DIMENSIONES Ø= 10.000" (254.0 mm) W= 2.520" (63.5 mm)

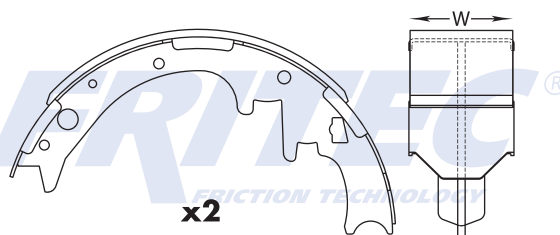
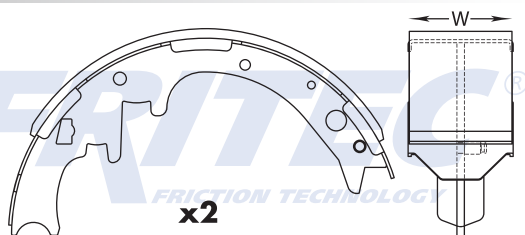

142

2089AT-ZV S705

DIMENSIONES Ø= 10.000" (254.0 mm) W= 2.500" (63.5 mm)

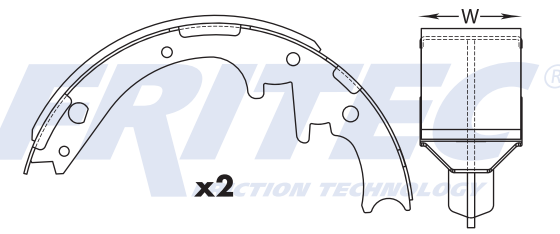
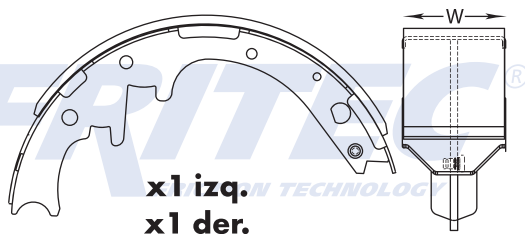

143

2089AT-Z1V S581

DIMENSIONES Ø= 10.000" (254.0 mm) W= 2.500" (63.5 mm)

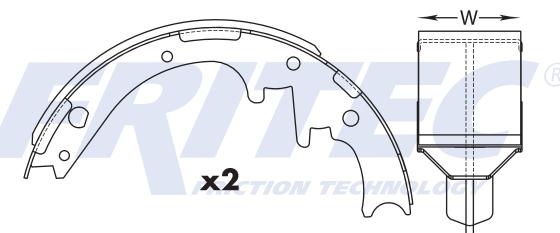
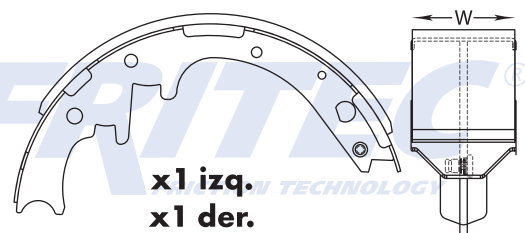

144

2117ATT-ZV S514

DIMENSIONES Ø= 9.500" (241.3 mm) W= 2.000" (50.8 mm)

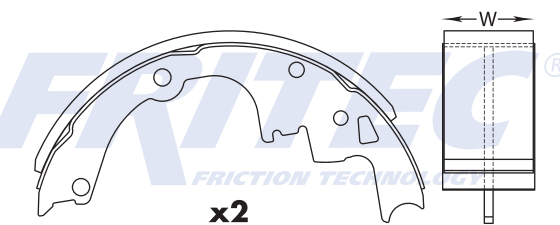
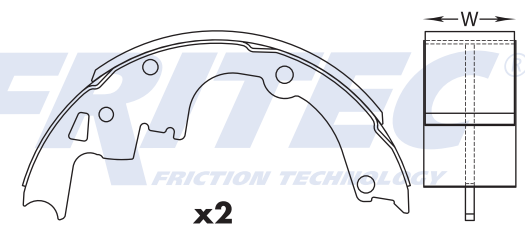

145

DIMENSIONES $\varnothing = 11.000''$ (279.4 mm) $W = 2.000''$ (50.8 mm)

2134BTT-ZR S652

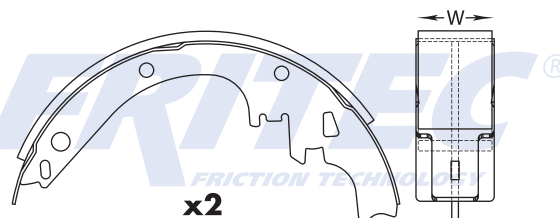
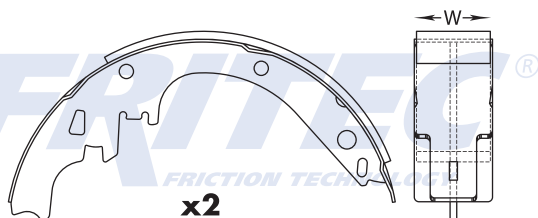

146

DIMENSIONES $\varnothing = 12.000''$ (304.8 mm) $W = 3.024''$ (76.8 mm)

2137-ZV S314

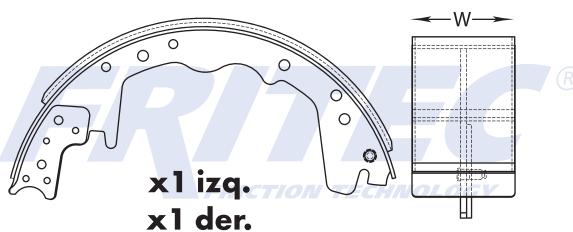
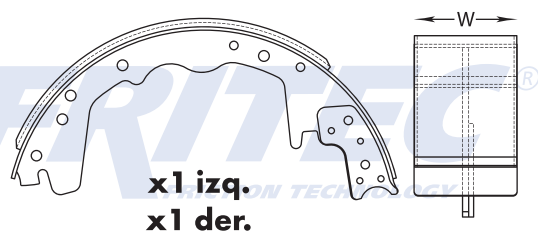

147

DIMENSIONES $\varnothing = 12.000''$ (305.0 mm) $W = 3.000''$ (76.2 mm)

2140AT-ZV S358

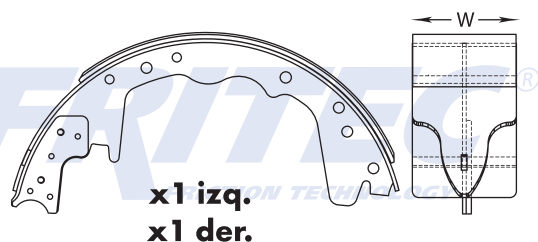

148

DIMENSIONES $\varnothing = 11.030''$ (280.0 mm) $W = 2.250''$ (57.2 mm)

2141AT-ZV S582

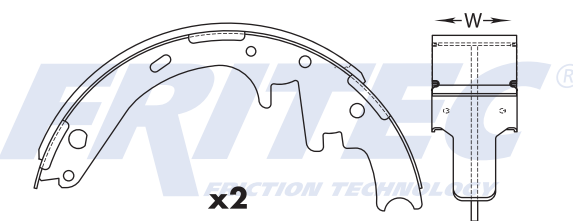
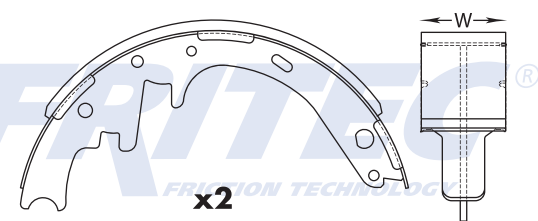

149

2146AT-ZV S357

DIMENSIONES Ø= 12.000" (304.8 mm) W= 2.520" (64.0 mm)

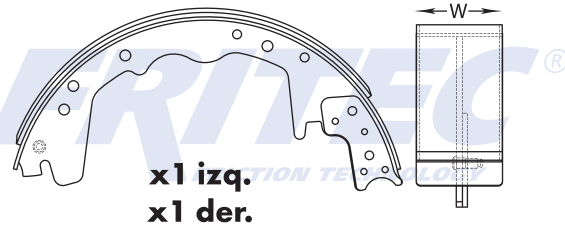
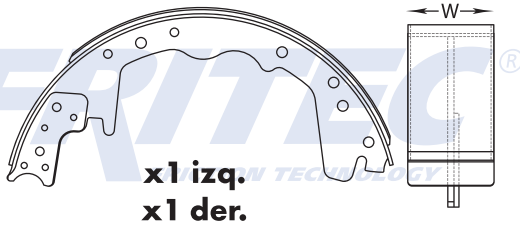

150

2157T-Z1R S452

DIMENSIONES Ø= 13.000" (330.2 mm) W= 3.500" (89.0 mm)

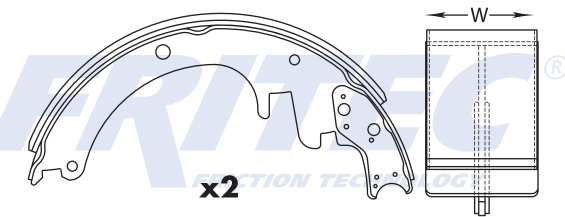
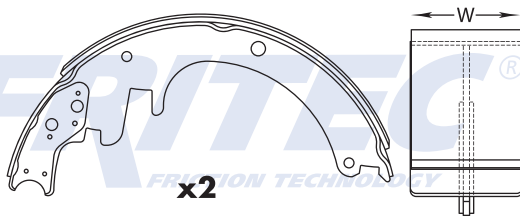

151

2159TT-ZV S449

DIMENSIONES Ø= 11.000" (279.4 mm) W= 2.000" (50.8 mm)

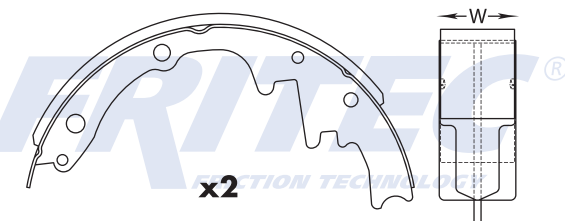
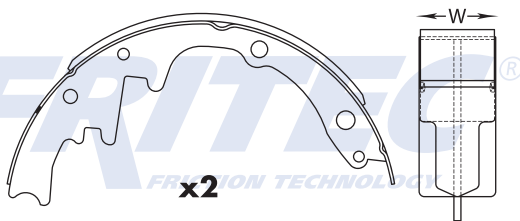

152

2164-ZV S553

DIMENSIONES Ø= 7.870" (200.0 mm) W= 1.770" (45.0 mm)

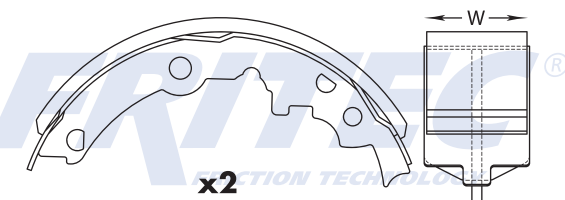
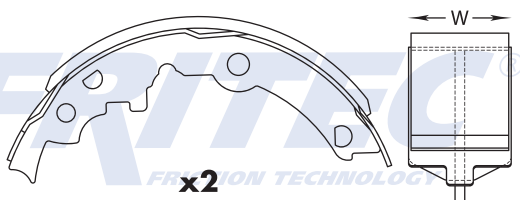

153

DIMENSIONES $\varnothing = 8.860''$ (225.0 mm) $W = 1.770''$ (45.0 mm)

2165T-ZV S552

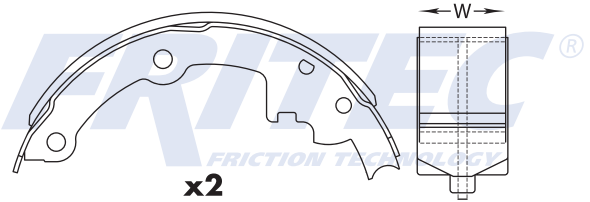
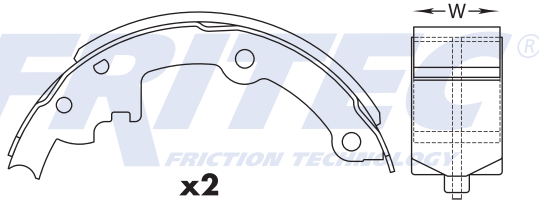

154

DIMENSIONES $\varnothing = 9.000''$ (228.6 mm) $W = 2.500''$ (63.5 mm)

2168T-ZV S538

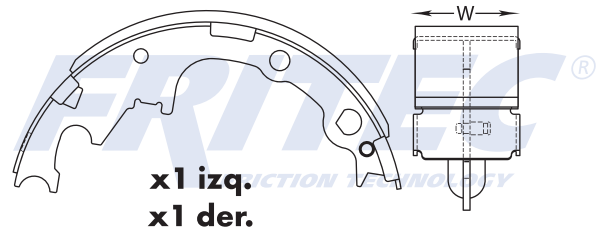

155

DIMENSIONES $\varnothing = 10.000''$ (254.0 mm) $W = 1.750''$ (44.5 mm)

2169-ZV S571

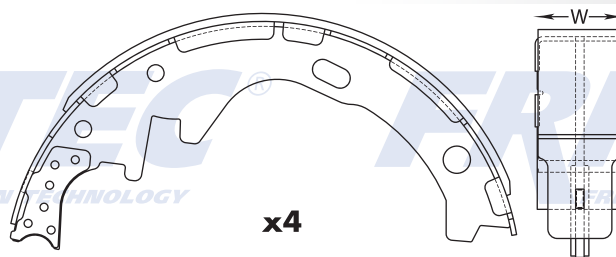

156

DIMENSIONES $\varnothing = 12.130''$ (308.0 mm) $W = 3.500''$ (89.0 mm)

2171T-ZV S583

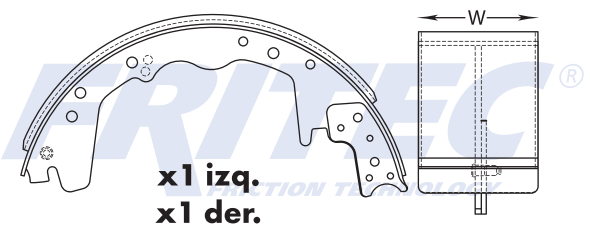
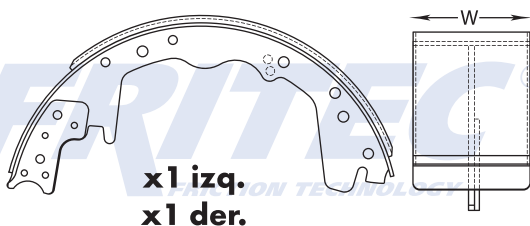

157

2174TT-ZV S670

DIMENSIONES Ø= 10.000" (254.0 mm) W= 1.750" (44.5 mm)

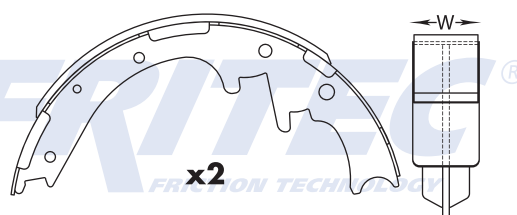
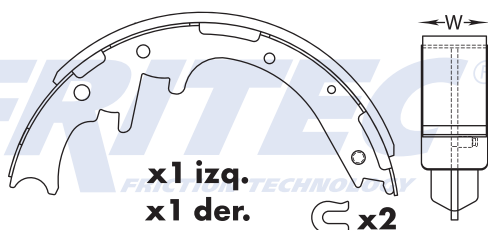

158

2180T-ZV S704

DIMENSIONES Ø= 9.000" (228.6 mm) W= 1.750" (44.5 mm)

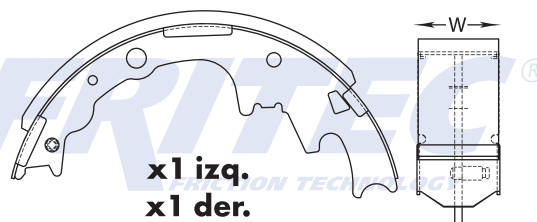
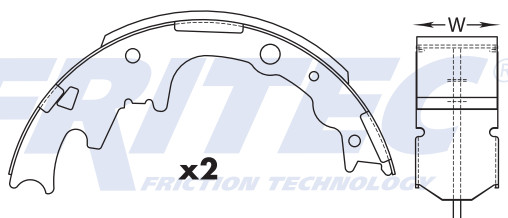

159

2182T-Z1V S734

DIMENSIONES Ø= 11.030" (280.0 mm) W= 2.250" (57.15 mm)

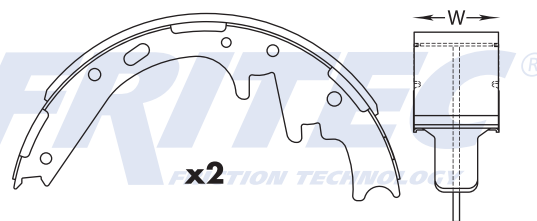
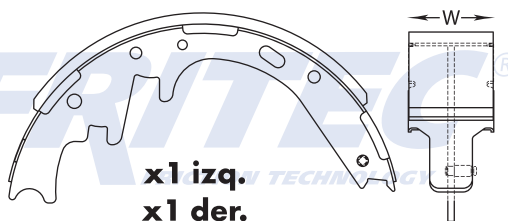

160

2182TT-ZV S723

DIMENSIONES Ø= 11.030" (280.0 mm) W= 2.250" (57.2 mm)

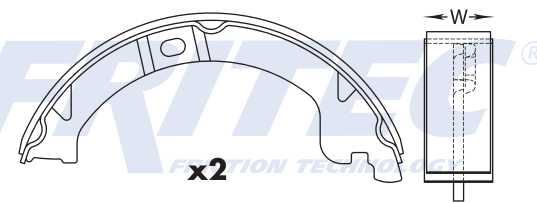
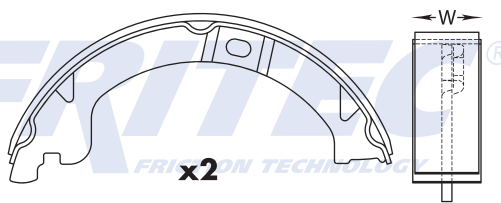

161

DIMENSIONES $\varnothing = 7.110''$ (180.6 mm) W= 1.175'' (29.8 mm)

2187-ZV S761

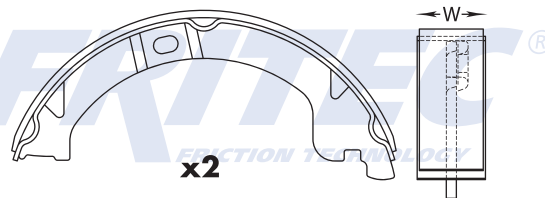
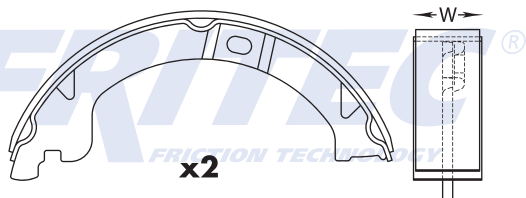

162

DIMENSIONES $\varnothing = 8.070''$ (205.0 mm) W= 1.732'' (44.0 mm)

2192-ZV S771

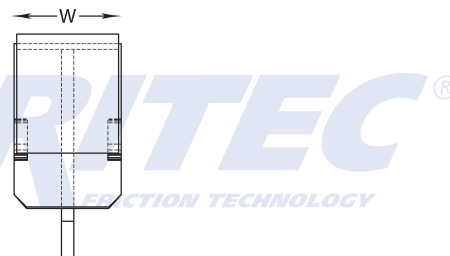
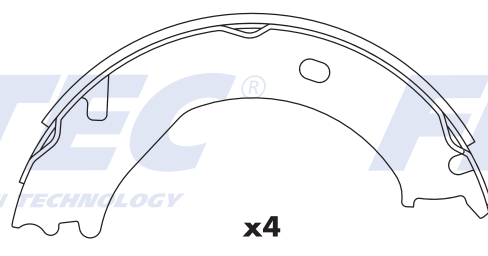

163

DIMENSIONES $\varnothing = 10.000''$ (254.0 mm) W= 1.750'' (44.5 mm)

2192-ZV S854

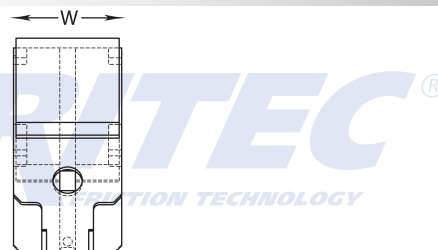
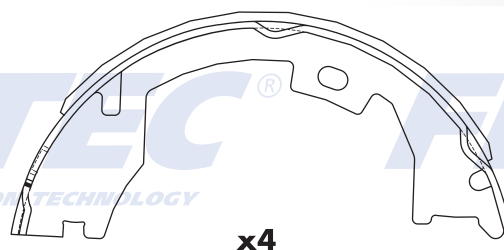

164

DIMENSIONES $\varnothing = 9.530''$ (242.0 mm) W= 2.440'' (62.0 mm)

2193-ZV S772

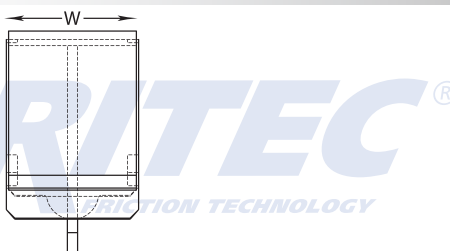
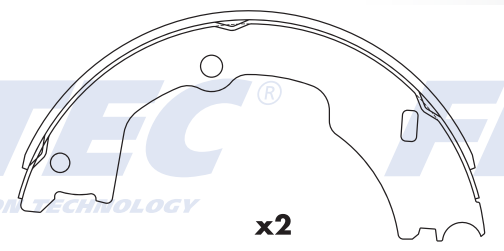

165

2202-ZV S812

DIMENSIONES

Ø= 7.100" (180.3 mm)

W= 1.180" (30.0 mm)

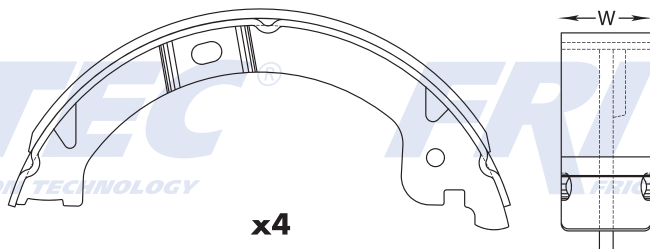

x4

166

2210T-ZV S1036

DIMENSIONES

Ø= 11.000" (279.4 mm)

W= 2.570" (65.3 mm)

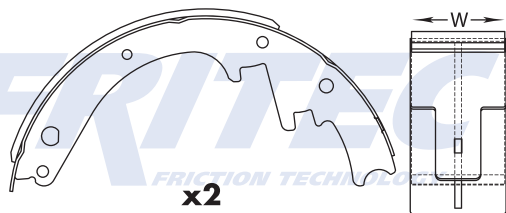

x2

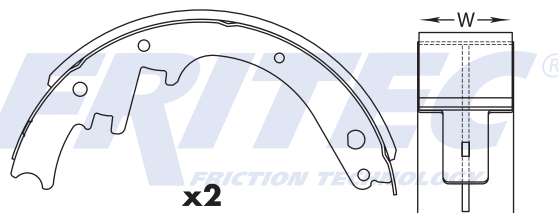

x2

167

2W61-ZV FT015

DIMENSIONES

Ø= 9.936" (252.4 mm)

W= 2.000" (50.8 mm)

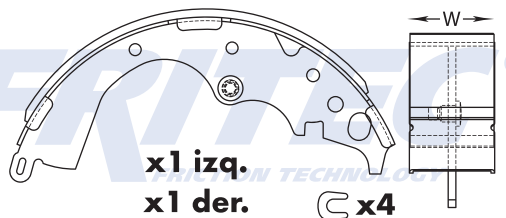

x1 izq.
x1 der.

x4

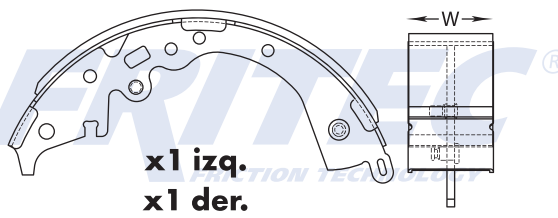

x1 izq.
x1 der.

168

2X64-ZV FT001

DIMENSIONES

Ø= 8.228" (209.0 mm)

W= 1.732" (44.0 mm)

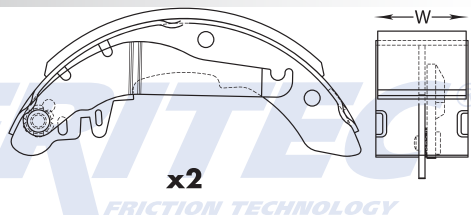

x2

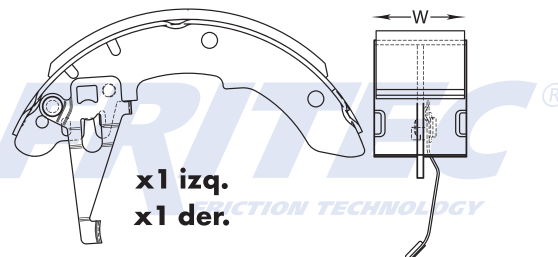

x1 izq.
x1 der.

169

DIMENSIONES Ø= 8.296" (210.7 mm) W= 1.457" (37.0 mm)

1664-ZV S993

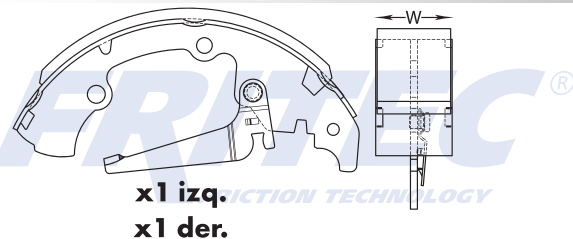
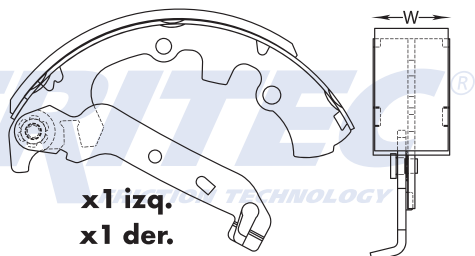

170

DIMENSIONES Ø= 7.820" (198.6 mm) W= 1.650" (42.0 mm)

2Y20-ZV FT111

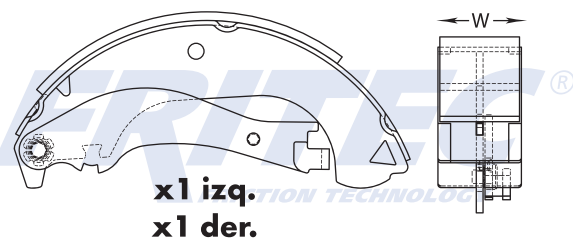
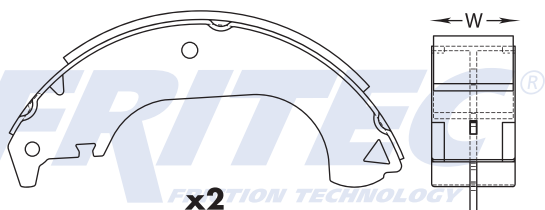

171

DIMENSIONES Ø= 9.920" (252.0 mm) W= 2.170" (55.0 mm)

8080-ZV S397

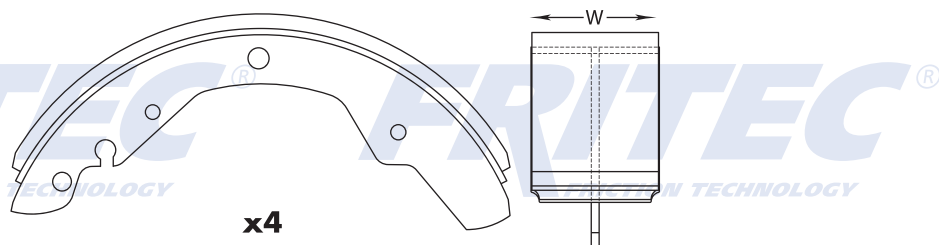

172

DIMENSIONES Ø= 8.000" (203.2 mm) W= 1.380" (35.0 mm)

8106-ZV S533

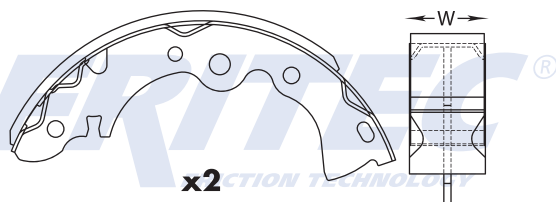
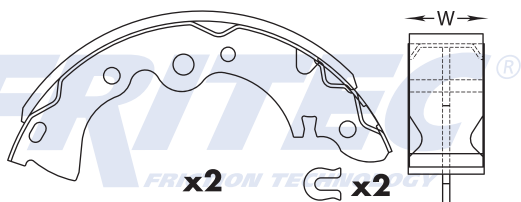

173

8123-ZV S406

DIMENSIONES

Ø= 10.000" (254.0 mm)

W= 1.815" (46.0 mm)

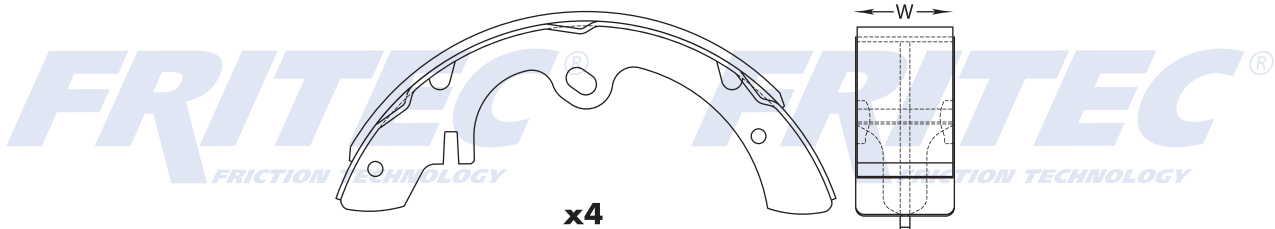

Autopar[®]
BRAKES



**El complemento
perfecto**



Productos FRITEC *Balatas automotrices y productos industriales*

Descubre todos nuestros productos



- **Aplicaciones**
- **Información Técnica**
- **Nuevos Lanzamientos y más...**



Dacomsa *s.A. de c.v.*

Calz. San Bartolo Naucalpan No. 136 Col. Argentina Poniente, C.P. 11230
Miguel Hidalgo, México, D.F Tel: (55) 5726 8203 y 5726 8286
LADA SIN COSTO: 01 800 201 8320

De la familia **MORESA**  **TF VICTOR**  **Autopar**  **TREMEC** 
Una empresa **kuo** 

C SF L 10 001-05 0818

INFORMACIÓN IMPORTANTE

La información contenida en este catálogo es la correcta hasta el momento de su impresión y está sujeta a cambios sin previo aviso; por lo cual no asumimos responsabilidad alguna por errores u omisiones, para actualizaciones consulte nuestro site de internet www.dacomsa.com

